

**TECHNICAL MANUAL
OPERATOR, ORGANIZATIONAL,
DIRECT SUPPORT,
AND GENERAL SUPPORT MAINTENANCE
FOR
SHELTER, TACTICAL,
NONEXPANDABLE
(NSN 5411-01-136-9837)**

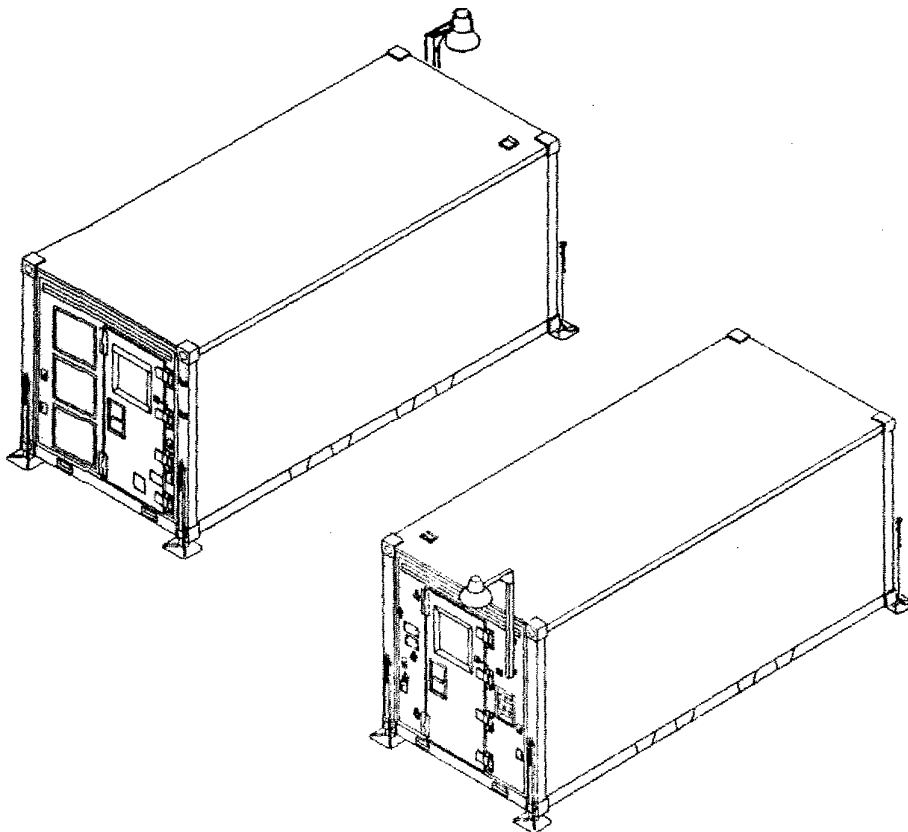

INTRODUCTION
Page 1-1
OPERATING INSTRUCTIONS
Page 2-1
OPERATOR MAINTENANCE INSTRUCTIONS
Page 3-1
ORGANIZATIONAL MAINTENANCE INSTRUCTIONS
Page 4-1
DIRECT SUPPORT MAINTENANCE INSTRUCTIONS
Page 5-1
GENERAL SUPPORT MAINTENANCE INSTRUCTIONS
Page 6-1
REFERENCES
Page A-1
MAINTENANCE ALLOCATION CHART
Page B-1
COMPONENTS OF END ITEM AND BASIC ISSUE ITEMS LIST
Page C-1
ADDITIONAL AUTHORIZED LIST
Page D-1
EXPENDABLE/DURABLE SUPPLIES AND MATERIALS LIST
Page E-1

WARNING

HIGH VOLTAGE

exists in the electrical system of this equipment

DEATH ON CONTACT

may result if personnel fail to observe safety precautions

DEATH ON CONTACT

may result shelter is used without grounding it first.

Before performing continuity checks or replacing electrical components, make sure that electrical power is completely disconnected from the circuit involved.

In the event of fluorescent lamp breakage, care must be taken in the removal of broken glass fragments and white phosphorous dust. Inhalation of phosphorous dust could cause serious injury.

Do not use handling equipment with capacity of less than gross weight of shelter system. Do not allow shelter to swing back and forth when it is suspended. Failure to observe this warning may result in damage to equipment or severe injury or death to personnel.

Methylethylketone (MEK) is flammable and toxic and must be used only in a well-ventilated area away from all sparks or open flame. Gloves should be worn during use.

In extreme cold, do not touch metal parts with bare hands. Severe skin damage may result.

Safety glasses must be worn by personnel when installing ground anchors.

Disconnect all power sources from power entry panel assembly before testing.

Disconnect all power sources from power entry panel assembly before removing.

The light assembly contains voltage that is dangerous if contacted.

CHANGE
NO. 7

HEADQUARTERS
DEPARTMENT OF THE ARMY
WASHINGTON, D.C., 31 AUGUST 2005

OPERATOR, ORGANIZATIONAL, DIRECT SUPPORT AND
GENERAL SUPPORT MAINTENANCE MANUAL
F O R
SHELTER, TACTICAL, NONEXPANDABLE
NSN 5411-01-136-9837

DISTRIBUTION STATEMENT A: -Approved for public release; distribution is unlimited.

TM 10-5411-202-14, dated 9 April 1987, is changed as follows:

1. File this sheet in the front of the manual for reference.
2. This change implements the Army Maintenance Transformation and changes the Maintenance Allocation Chart (MAC) to Support Field and Sustainment Maintenance.
3. New or updated text is indicated by a vertical bar in the *outer* margin.
4. Added illustrations are indicated by a vertical bar adjacent to the figure number. Changed illustrations are indicated by a miniature hand adjacent to the updated area and a vertical bar adjacent to the figure number.
5. Remove old pages and insert new pages as indicated below.

Remove Pages

B-1 -73-8

2028 Sample/Envelope
2028 Front/Envelope
2028 Front/Envelope

Insert Pages

A/(B Blank)

B-1 -B-8

2028 Electronic
Instructions/Blank 2028 Sample
Front/Back
2028 Front/Back
2028 Front/Back

By Order of the Secretary of the Army

PETER J. SCHOOMAKER
General, United States
Army Chief of Staff

Official:

Distribution:

SANDRA R. RILEY
Administrative Assistant to the
Secretary of the Army
0516416

To be distributed in accordance with IDN 252539, Operator, Organizational, Direct Support and General Support Maintenance requirements for TM 10-5411-202-14.

CHANGE

NO. 6

HEADQUARTERS
DEPARTMENT OF THE ARMY
WASHINGTON, D.C., 17 September 1995

Operator, Organizational, Direct Support and
General Support Maintenance

SHELTER, TACTICAL, NONEXPANDABLE,
(NSN 5411-01-136-9837) 60 AMP MODEL
(NSN 5411-01-294-6390) 100 AMP MODEL

DISTRIBUTION STATEMENT A: Approved for public release; distribution is unlimited.

TM 10-5411-202-14, 9 April 1987 is changed as follows:

1. Remove and insert pages as indicated below. New or changed text material is indicated by a vertical bar in the margin. An illustration change is indicated by a miniature pointing hand.

Remove pages

i and ii
4-44.1/(4-44.2 blank)
4-65 through 4-68
Index-1 through Index-3/(Index-4 blank)

Insert pages

i and ii
4-44.1 and 4-44.2
4-65 through 4-68
Index-1 through Index-3/(Index-4 blank)

2. Retain this sheet in front of manual for reference purposes.

By Order of the Secretary of the Army:

Official:

Yvonne M. Harrison
YVONNE M. HARRISON
Administrative Assistant to the
Secretary of the Army
00958

DENNIS J. REIMER
General, United States Army
Chief of Staff

DISTRIBUTION:

To be distributed in accordance with DA Form 12-25-E, block no. 2539, requirements for TM 10-5411-202-14.

CHANGE

NO. 5

HEADQUARTERS
DEPARTMENT OF THE ARMY
WASHINGTON, D.C., 15 December 1993

Operator, Organizational, Direct Support and General Support Maintenance

SHELTER, TACTICAL, NONEXPANDABLE
(NSN 5411-01-136-9837) 60 AMP MODEL
(NSN 5411-01-294-6390) 100 AMP MODEL

DISTRIBUTION STATEMENT A: Approved for public release: distribution is unlimited.

TM 10-5411-202-14, 9 April 1987, is changed as follows:

1. Remove and insert pages as indicated below. New or changed text material is indicated by a vertical bar in the margin. An illustration change is indicated by a miniature pointing hand.

Remove pages

i through iii/(iv blank)
1-1 through 1-4
2-1 through 2-8
2-11 and 2-12
2-17 and 2-18
2-18.1/(2-18.2 blank)
3-3 through 3-6
4-5 and 4-6
4-9 and 4-10
4-19 through 4-26
4-35 through 4-44

4-45 through 4-48
4-48.1/(4-48.2 blank)
4-73 through 4-86
4-11 and 4-112
4-121 through 4-124
4-124.1 through 4-124.3/
(4-124.4 blank)
5-1 through 5-9/5-10
B-5 and B-6
D-1/D-2 blank)
E-1 through E-3/(E-4 blank)
Index-1 through Index-3/
(Index-4 blank)

Insert pages

i through iii/(iv blank)
1-1 through 1-4
2-1 through 2-8
2-11 and 2-12
2-17 and 2-18

3-3 through 3-6
4-5 and 4-6
4-9 and 4-10
4-19 through 4-26
4-35 through 4-44
4-44.1/(4-44.2 blank)
4-45 through 4-48
4-48.1 through 4-48.8
4-73 through 4-86
4-111 and 4-112
4-121 through 4-124
4-124.1 through 4-124.3/
(4-124.4 blank)
5-1 through 5-5/(5-6 blank)
B-5 and B-6
D-1/(D-2 blank)
E-1 through E-3/(E-4 blank)
Index-1 through Index-3/
(Index-4 blank)

2. Retain this sheet in front of manual for reference purposes.

TM 10-5411-202-14

C 5

By Order of the Secretary of the Army:

GORDON R. SULLIVAN
General, United States Army
Chief of Staff

Official:

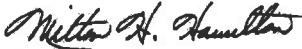
MILTON H. HAMILTON
Administrative Assistant to the
Secretary of the Army

05952

DISTRIBUTION:

To be distributed in accordance with DA Form 12-25-E, block no. 2539, requirements for TM 10-5411-202-14.

CHANGE

NO. 4

HEADQUARTERS
DEPARTMENT OF THE ARMY
WASHINGTON, D.C., 17 September 1991

Operator, Organizational, Direct Support and General Support Maintenance

SHELTER, TACTICAL, NONEXPANDABLE (NSN
5411-01-136-9837) 60 AMP MODEL (NSN 5411-01-
294-6390) 100 AMP MODEL

Approved for public release; distribution is unlimited

TM 10 5411-202-14, 9 April 1987 is changed as follows:

1. Remove and insert pages as indicated below. New or changed text material is indicated by a vertical bar in the margin. An illustration change is indicated by a miniature pointing hand.

Remove pages

1-1 through 1-5/1-6
C-3 and C-4

Insert pages

1-1 through 1-6
C-3 and C-4

1. Retain this sheet in front of manual for reference purposes. **By**

Order of the Secretary of the Army:

GORDON R. SULLIVAN
General, United States Army
Chief of Staff

Official:

PATRICIA P. HICKERSON
Brigadier General, United States Army
The Adjutant General

DISTRIBUTION:

To be distributed in accordance with DA Form 12-25E, (qty rqr block no. 2539).

CHANGE

No. 3

HEADQUARTERS
DEPARTMENT OF THE ARMY
WASHINGTON, D.C., 1 December 1989

OPERATOR, ORGANIZATIONAL, DIRECT SUPPORT
AND GENERAL SUPPORT MAINTENANCE

SHELTER, TACTICAL, NONEXPANDABLE
(NSN: 5411-01-136-9837) 60 AMP MODEL
(NSN: 5411-01-294-6390) 100 AMP MODEL

Approved for public release. Distribution is unlimited.

TM 10-5411-202-14, 9 April 1987, is changed as follows:

1. Title is changed as shown above.
2. Remove and insert pages as indicated below. New or changed text material is indicated by a vertical bar in the margin. An illustration change is indicated by a miniature pointing hand.

Remove pages

i and ii
1-1 and 1-2
1-5/1-6
2-1 and 2-2

2-9 through 2-14
2-17 and 2-18
2-21 and 2-22
4-1 and 4-2
4-5 through 4-12

4-13 through 4-16
4-23 through 4-32
4-35 and 4-36
4-39 and 4-40
4-45 through 4-48

4-119 and 4-120

4-121 through 4-124

4-125/4-126
5-3 and 5-4
A-1/A-2
E-1 and E-2

Index 1 through Index 3/4

Insert pages

i and ii
1-1 and 1-2
1-5/1-6
2-1 and 2-2
2-9 through 2-14
2-17 and 2-18
2-18.1/2-18.2
2-21 and 2-22
4-1 and 4-2
4-5 through 4-12
4-12.1 through 4-12.3/4-12.4
4-13 through 4-16
4-23 through 4-32
4-35 and 4-36
4-39 and 4-40
4-45 through 4-48
4-48.1/4-48.2
4-119 and 4-120
4-120.1/4-120.2
4-121 through 4-124
4-124.1 through 4-124.3/4-124.4
4-125/4-126
5-3 and 5-4
A-1/A-2
E-1 and E-2
E-3/E-4
Index 1 through Index 3/4

By Order of the Secretary of the Army:

CARL E. VUONO *General,*
United States Army,, Chief of Staff

Official:

WILLIAM J. MEEHAN, II
Brigadier General, United States Army
The Adjutant General

DISTRIBUTION:

To be distributed in accordance with DA Form 12-25A, Operator, Unit, Direct Support and General Support Maintenance requirements for Shelter, Tactical, Non-Expandable (5411-01-136-9837).

CHANGE }
NO. 2 }

HEADQUARTER
DEPARTMENT OF THE ARMY
WASHINGTON, D.C., 31 July 1989

Operator, Organizational, Direct Support
and General Support Maintenance

SHELTER, TACTICAL, NONEXPANDABLE
(NSN 5411-01-136-9837)

Approved for public release. Distribution is unlimited.

TM 10-5411-202-14, 9 April 1987, is changed as follows:

1. Remove and insert pages as indicated below. New or changed text material is indicated by a vertical bar in the margin. An illustration change is indicated by a miniature pointing hand.

Remove pages

1-3 and 1-4

2-21 and 2-22

D-1/D-2

Insert pages

1-3 and 1-4

2-21 and 2-22

D-1/D-2

2. Retain this sheet in front of manual for reference purposes.

By Order of the Secretary of the Army:

Army Official:

WILLIAM J. MEEHAN, II
Brigadier General, United States Army
The Adjutant General

CARL E. VUONO
General, United States
Chief of Staff

DISTRIBUTION:

To be distributed in accordance with DA Form 12-25A, Operator, Unit, Direct Support and General Support Maintenance requirements for Shelter, Tactical, Non-Expandable (5411-01-136-9837).

CHANGE }
NO. 1 }

HEADQUARTERS
DEPARTMENT OF THE ARMY
WASHINGTON, D.C., 25 April 1989

Operator, Organizational, Direct Support
and General Support Maintenance

SHELTER, TACTICAL, NONEXPANDABLE
(NSN 5411-01-136-9837)

TM 10-5411-202-14, 9 April 1987, is changed as follows:

1. , Remove and insert pages as indicated below. New or changed text material is indicated by a vertical bar in the margin. An illustration change is indicated by a miniature pointing hand.

Remove pages

Insert pages

i and ii

D-1/D-2

i and ii

D-1/D-2

2. Retain this sheet in front of manual for reference purposes.

By Order of the Secretary of the Army:

CARL E. VUONO
General, United States Army
Chief of Staff

Official:

WILLIAM J. MEEHAN, II
Brigadier General, United States Army
The Adjutant General

DISTRIBUTION:

To be distributed in accordance with DA Form 12-25A, Operator, Unit, Direct Support and General Support Maintenance requirements for Shelter, Expandable, Rigid Construction, w/Air Lock Model SEU-2 (TM 10-5410-221 Series) and Shelter, Expandable, Shop, Aircraft Maintenance, Portable (TM 10-5410-224 Series).

INSERT LATEST CHANGED PAGES. DESTROY SUPERSEDED PAGES.

LIST OF EFFECTIVE PAGES

NOTE: The portion of text affected by the changes is indicated by a vertical line in the outer margins of the page. Changes to illustrations are indicated by shaded or screened areas, or by miniature pointing hands. Zero in the "Change No." column indicates an original page.

Dates of issue for original and changed pages are:

Original ...0 ...	9 April 1987	Change ...4 ...	17 September 1991
Change ...1 ...	25 April 1989	Change ...5 ...	15 December 1993
Change ...2 ...	31 July 1989	Change ...6 ...	17 September 1995
Change ...3 ...	1 December 1989	Change ...7 ...	31 August 2005

TOTAL NUMBER OF PAGES IN THIS PUBLICATION IS 136, CONSISTING OF THE FOLLOWING:

Page No.	Change No.	Page No.	Change No.	Page No.	Change No.
Title	0	4-10	5	B-1 - B-8	7
a/(b Blank)	0	4-11 - 4-12.3/4-12.4 blank)	3	C-1 - C-3	0
1-ii	6	4-13	0	C-4	4
iii/(iv blank)	5	4-14	3	D-1/(D-2 blank)	5
1-1	5	4-15	0	E-1	0
1-2	0	4-16	3	E-2 - E-3/(E-4 blank)	5
1-3 - 1-4	5	4-17 - 4-19	0	INDEX-1	6
1-5 - 1-6	4	4-20 - 4-25	5	INDEX-2	3
2-1 - 2-3/(2-4 blank)	5	4-26 - 4-31	3	INDEX-3/(INDEX-4 blank)	6
2-5	0	4-32 - 4-35	0	Back Cover	0
2-6 - 2-8	5	4-36 - 4-40	5		
2-9 - 2-10	3	4-41	0		
2-11	5	4-42 - 4-44.1	5		
2-12	0	4-44.2	6		
2-13	3	4-45 - 4-48.8	5		
2-14 - 2-16	0	4-49 - 4-65	6		
2-17 - 2-18	5	4-67 - 4-72	0		
2-19 - 2-20	0	4-73 - 4-81	5		
2-21 - 2-22	3	4-82	0		
2-23 - 2-26	0	4-83 - 4-85	5		
3-1 - 3-2	0	4-86 - 4-111	0		
3-3	5	4-112	5		
3-4 - 3-5	0	4-113 - 4-119	0		
3-6	5	4-120.1/(4-120 2 blank)	3		
3-7 - 3-9/(3-10 blank)	0	4-121	0		
4-1	0	4-122 - 4-124.3/(4-124.4 blank)	5		
4-2	3	4-125/(4-126 blank)	3		
4-3 - 4-4	0	5-1 - 5-5(5-6 blank)	5		
4-5 - 4-6	5	6-1 - 6-6	0		
4-7 - 4-9	3	A-1/(A-2 blank)	3		

TECHNICAL MANUAL
No. TM 10-5411-202-14

HEADQUARTERS
DEPARTMENT OF THE ARMY
WASHINGTON, D.C., 9 April 1987

OPERATOR, ORGANIZATIONAL, DIRECT SUPPORT,
AND GENERAL SUPPORT MAINTENANCE

SHELTER, TACTICAL, NONEXPANDABLE
(NSN: 5411-01-136-9837) 60 AMP MODEL
(NSN: 5411-01-294-6390) 100 AMP MODEL

REPORTING ERRORS AND RECOMMENDING IMPROVEMENTS

You can help improve this manual. If you find any mistakes, or if you know of a way to improve these procedures, please let us know. Mail your letter or DA Form 2028 (Recommended Changes to Publications and Blank Forms), or DA Form 2028-2 located in the back of this manual directly to: Commander, US Army Aviation and Troop Command, ATTN: AMSAT-I-MP, 4300 Goodfellow Blvd., St. Louis, MO 63120-1798. You may also submit your recommended changes by E-mail directly to daf2028@st-louis-emh7.army.mil. A reply will be furnished directly to you.

The following format shall be used for electronic 2028s. The subject line must be exactly the same and all fields must be included; however only the following fields are mandatory: 1, 3, 4, 5, 6, 7, 8, 9, 10, 13, 15, 16, 17, and 27.

From: "Whomever" <whomever@avma27.army.mil>
To: daf2028@st-louis-emh7.army.mil
Subject: DA Form 2028

- | | |
|--|---|
| 1. From: Joe Smith | 15. Submitter LName: Smith |
| 2. Unit: home | 16. Submitter Phone: 123-123-1234 |
| 3. Address: 4300 Park | 17. Problem: 1 |
| 4. City: Hometown | 18. Page: 2 |
| 5. St: MO | 19. Paragraph: 3 |
| 6. Zip: 7777 | 20. Line: 4 |
| 7. Date Sent: 19-OCT-93 | 21. NSN: 5 |
| 8. Pub no: 55-2840-229-23 | 22. Reference: 6 |
| 9. Pub Title: TM | 23. Figure: 7 |
| 10. Publication Date: 04-JUL-85 | 24. Table: 8 |
| 11. Change Number: 7 | 25. Item: 9 |
| 12. Submitter Rank: MSG | 26. Total: 123 |
| 13. Submitter FName: Joe | 27. Text: |
| 14. Submitter MName: T | This is the text for the problem below line 27. |

DISTRIBUTION STATEMENT A: Approved for public release. Distribution is unlimited.

TABLE OF CONTENTS

		Page
CHAPTER 1	INTRODUCTION	1-1
Section	I. General Information	1-1
Section	II. Equipment Description and Data	1-2

TABLE OF CONTENTS - Continued

	Page
CHAPTER 2 OPERATING INSTRUCTIONS	2-1
Section I. Description and Use of Operator's Controls and Indicators	2-1
Section II. Operator's Preventive Maintenance Checks and Services (PMCS)	2-5
Section III. Setup of Shelter	2-10
Section IV. Operation Under Usual Conditions	2-23
Section V. Operation Under Unusual Conditions	2-23
 CHAPTER 3 OPERATOR MAINTENANCE INSTRUCTIONS	 3-1
Section I. Troubleshooting Procedures	3-1
Section II. Operator Maintenance Procedures	3-4
 CHAPTER 4 ORGANIZATIONAL MAINTENANCE INSTRUCTIONS	 4-1
Section I. Repair Parts, Special Tools, TMDE, and Support Equipment	4-1
Section II. Preventive Maintenance Checks and Services	4-1
Section III. Troubleshooting Procedures	4-2
Section IV. Organizational Maintenance Procedures	4-6
Section V. Common Repairs	4-90
Section VI. Preparation for Storage and Shipment	4-125
 CHAPTER 5 DIRECT SUPPORT MAINTENANCE INSTRUCTIONS	 5-1
CHAPTER 6 GENERAL SUPPORT MAINTENANCE INSTRUCTIONS	6-1
APPENDIX A REFERENCES	A-1
APPENDIX B MAINTENANCE ALLOCATION CHART	B-1
APPENDIX C COMPONENTS OF END ITEM LIST	C-1
APPENDIX D ADDITIONAL AUTHORIZED LIST	D-1
APPENDIX E EXPENDABLE/DURABLE SUPPLIES AND MATERIALS LIST	E-1
INDEX	Index-1

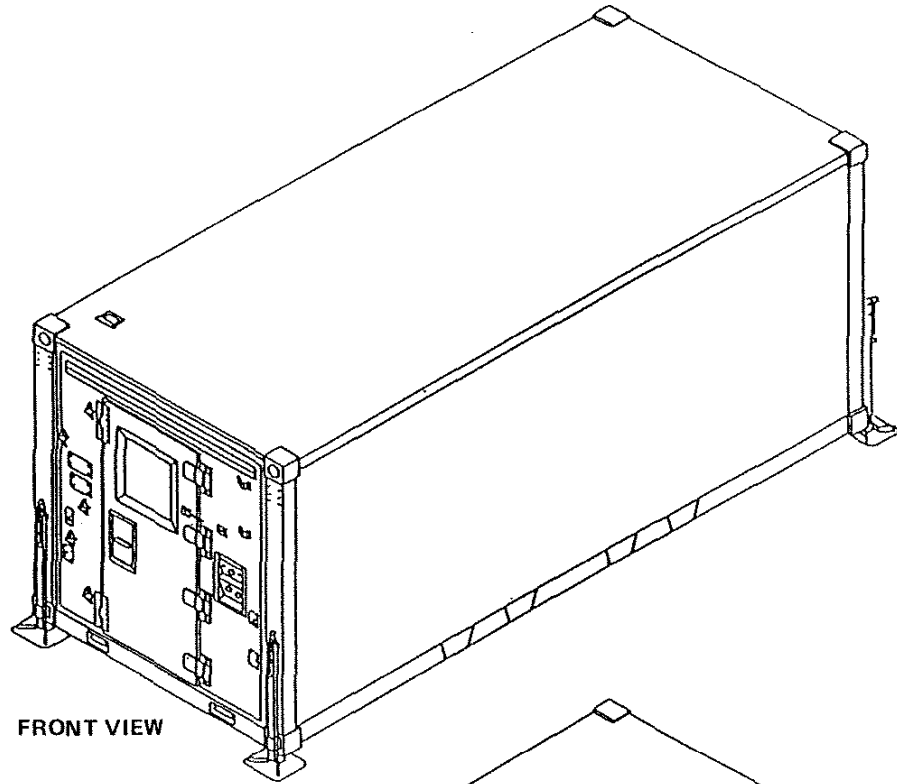

FRONT VIEW

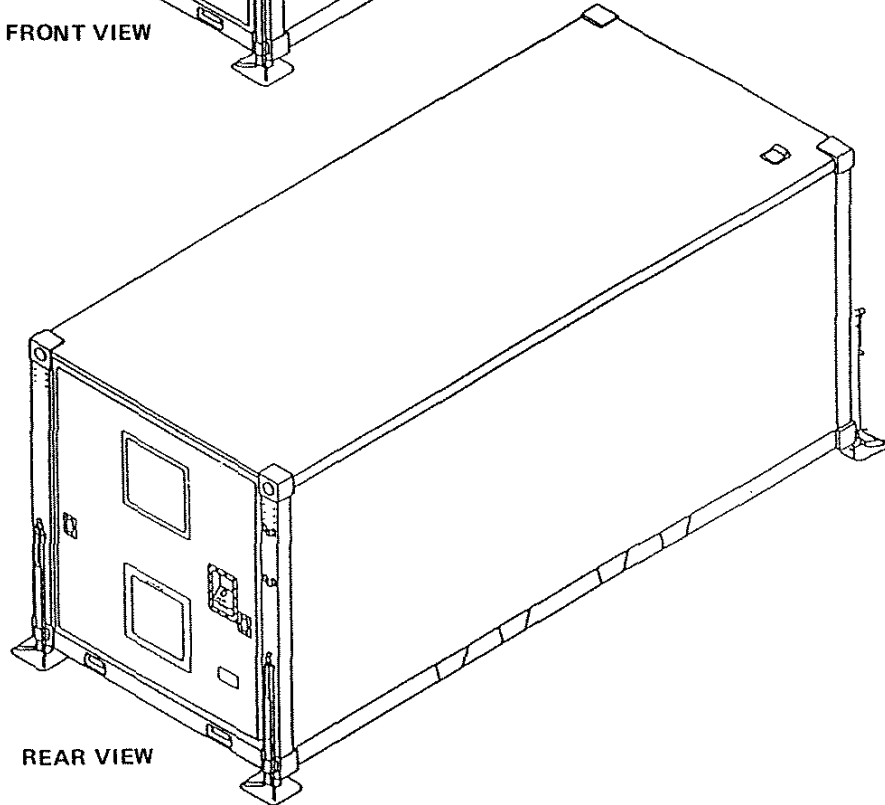

REAR VIEW

Full External View of Nonexpandable Tactical Shelter

CHAPTER 1 INTRODUCTION

Section I GENERAL INFORMATION

1-1. SCOPE. This manual is for use by personnel responsible for operation and maintenance of the nonexpandable tactical shelter, which will be referred to as the shelter. It provides the user with necessary instructions to use the shelter and to perform required maintenance in accordance with the Maintenance Allocation Chart in Appendix B.

1-2. MAINTENANCE FORMS, RECORDS, AND REPORTS. Maintenance forms, records, and reports used by:

- a. Are prescribed by DA PAM 738-750, the Army Maintenance Management System (TAMMS).
- b. Users shall refer to the Maintenance Allocation Chart (MAC) for task and levels of maintenance to be performed.

1-3. DESTRUCTION OF MATERIAL TO PREVENT ENEMY USE. For destruction procedures for material refer to TM 750-244-3.

1-4. ADMINISTRATIVE STORAGE. For procedures and inspections required during administrative storage, refer to Chapter 4, paragraph 4-43.

1-5. REPORTING EQUIPMENT IMPROVEMENT RECOMMENDATIONS (EIR'S). If your shelter needs improvement, let us know. Send us an EIR. You, the user, are the only one who can tell us what you don't like about your equipment. Let us know why you don't like the design. Tell us why a procedure is hard to perform. Put it on an SF 368 (Quality Deficiency Report). Mail it to: Commander, U.S. Army Aviation and Troop Command ATTN: AMSAT—I—MDO, 4300 Goodfellow Boulevard, St. Louis, Missouri 63120-1798. We'll send you a reply.

1-6. LIST OF ABBREVIATIONS.

AC	Air Conditioner
cm	centimeter
CSC	(International) Convention for Safe Containers
ECU	Environmental Control Unit
EIR	Equipment Improvement Recommendation
ft	foot (feet)
Hz	Hertz
in	inch
ISO	International Standards Organization

kg	Kilogram
lb	pound
lg	long
MAC	Maintenance Allocation Chart
MEK	Methylethylketone (Solvent)
mm	millimeter
MTOE	Modified Table of Organization and Equipment
No.	number
PMCS	Preventive Maintenance Checks and Services
ref	reference
sq	square
TMDE	Test, Measurement and Diagnostic Equipment
Vac	Volts, alternating current

Section II. EQUIPMENT DESCRIPTION AND DATA

1-7. PURPOSE OF NONEXPANDABLE TACTICAL SHELTER. A self-contained transportable multi-application utility shelter. A member of family of standard rigid wall ISO shelters to be used by the Army.

Capabilities and Features:

- Equipped with standard ISO fittings for easy transportability.
- Provided with mobilizer fittings for mobilizer transportation.
- Built-in fork lift provisions.
- All weather operation.
- Environmentally controlled interior.
- Rigid wall construction.
- Simple and fast deployment.
- Designed to operate under blackout conditions with door activated blackout switch.
- External electrical power connection.
- Easy to maintain.

1-8. LOCATION AND DESCRIPTION OF MAJOR COMPONENTS.

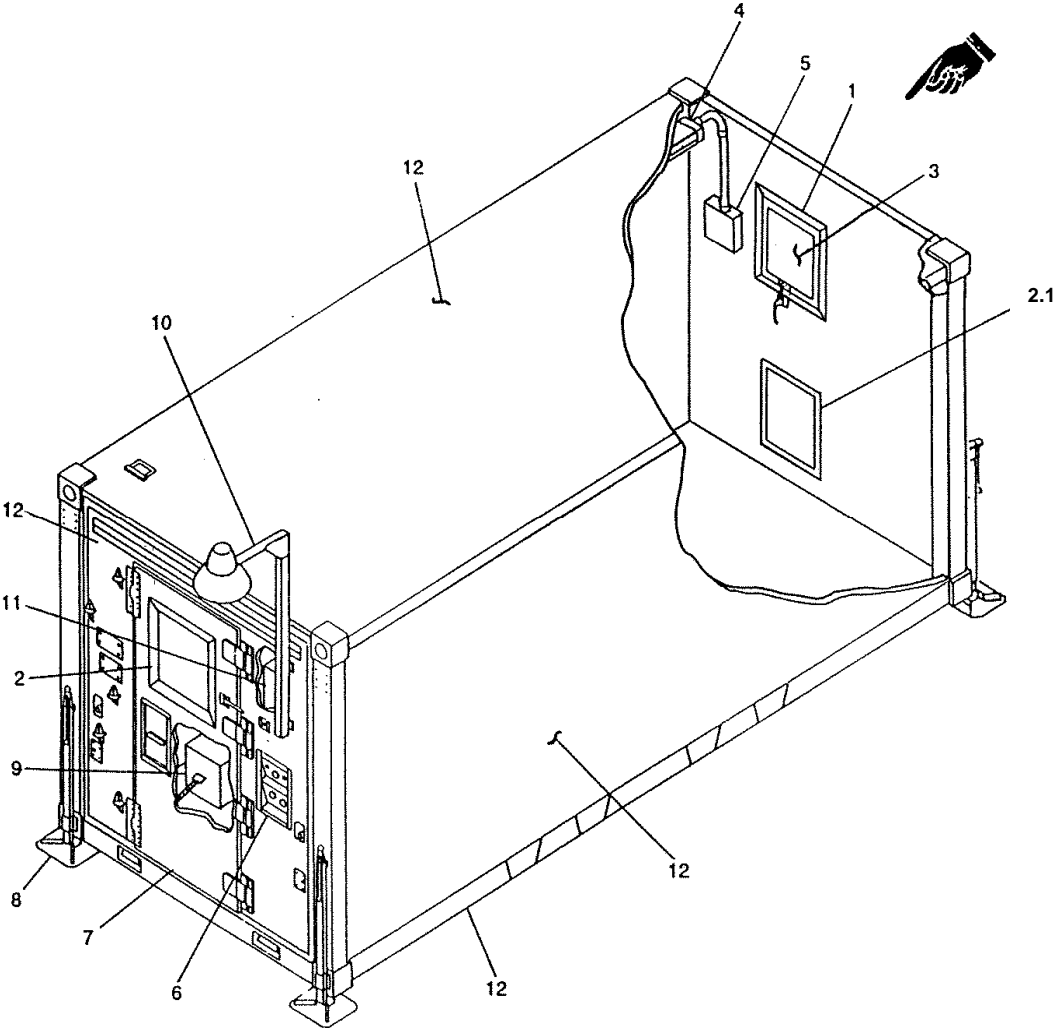

1-8. (cont)

1. ESCAPE HATCH. Provides emergency escape from rear of shelter.
2. DOOR VENTS. Manually operated vents provide ventilation for the shelter. These vents must be open when the shelter is transported by an aircraft.
- 2.1 ECU INTAKE PANEL. Delivers environmentally controlled air from externally installed ECU.
3. ECU RETURN PANEL. Returns recirculated air to externally installed environmental control unit (ECU).

WARNING

Shelter grounding is not optional on shelters used for Deployable Medical Systems (DEPMEDS).

4. RACEWAY ASSEMBLY. Provides primary power to power panel ECU.
5. POWER PANEL ECU. An external power panel to supply power to environmental control units.
6. POWER ENTRY PANEL. A service entrance connector on this panel receives external primary input power for the shelter and routes it to a circuit breaker panel inside the shelter. Includes provisions for optional shelter grounding and telephone connections.
7. FRONT PERSONNEL DOOR. Provides access to shelter. During blackout conditions only this door is used.
8. CONTAINER LIFT JACKS. Provide means for leveling shelter.
9. EQUIPMENT CONTAINER. Contains fan cover, ground anchor assemblies, 150-watt floodlight, screwdriver, drive rod, drive head, and drive handle.
10. AREA LIGHT. Attaches to either endwall panel to provide illumination around the shelter area. Plugs into receptacle on the power entry panel.
11. CIRCUIT BREAKER PANEL. Provides overload protection for the shelter circuits. Main circuit breaker switches off all electrical power to the shelter.
12. FIXED PANELS. Consists of front personnel endwall, rear fixed endwall, fixed floor, fixed walls, and fixed roof panels. Used for equipment storage during transportation.

Differences Between Models:

- The early model Shelter, Tactical, Expandable, Two-sided (NSN 5411-01-136-9837), provides overload protection through a 60 amp or 100 amp Model NQOB circuit breaker panel, manufactured by Square D Company. When replacement of the circuit breaker panel is necessary, the replacement will be Model NQOD circuit breaker panel, which is also manufactured by Square D Company and has the capability to accommodate either 60 amp or 100 amp service. Model NQOD is two inches shorter in length than the earlier Model NQOB, and modifications to the shelters are required when replacement is necessary (see paragraph 4-7.1).

NOTE

All electrical components (circuit breakers, switches, and wiring) used in the earlier model circuit breaker panel are compatible with the new model NQOD.

- The late model Shelters, Tactical, Expandable, Two-Sided (NSN 5411-01-294-6390) are initially equipped with the new Model NQOD circuit breaker panel when placed into service.

CHAPTER 2

OPERATING INSTRUCTIONS

Section I. DESCRIPTION AND USE OF OPERATOR'S CONTROLS AND INDICATORS

2-1. SCOPE. This section provides description and use of operator controls and indicators needed to operate shelter. This section provides descriptions for circuit breaker panel controls and indicators (See paragraph 2-2), front personnel end panel mounted controls and indicators (See paragraph 2-3), and rear end panel mounted controls and indicators (See paragraph 2-4).

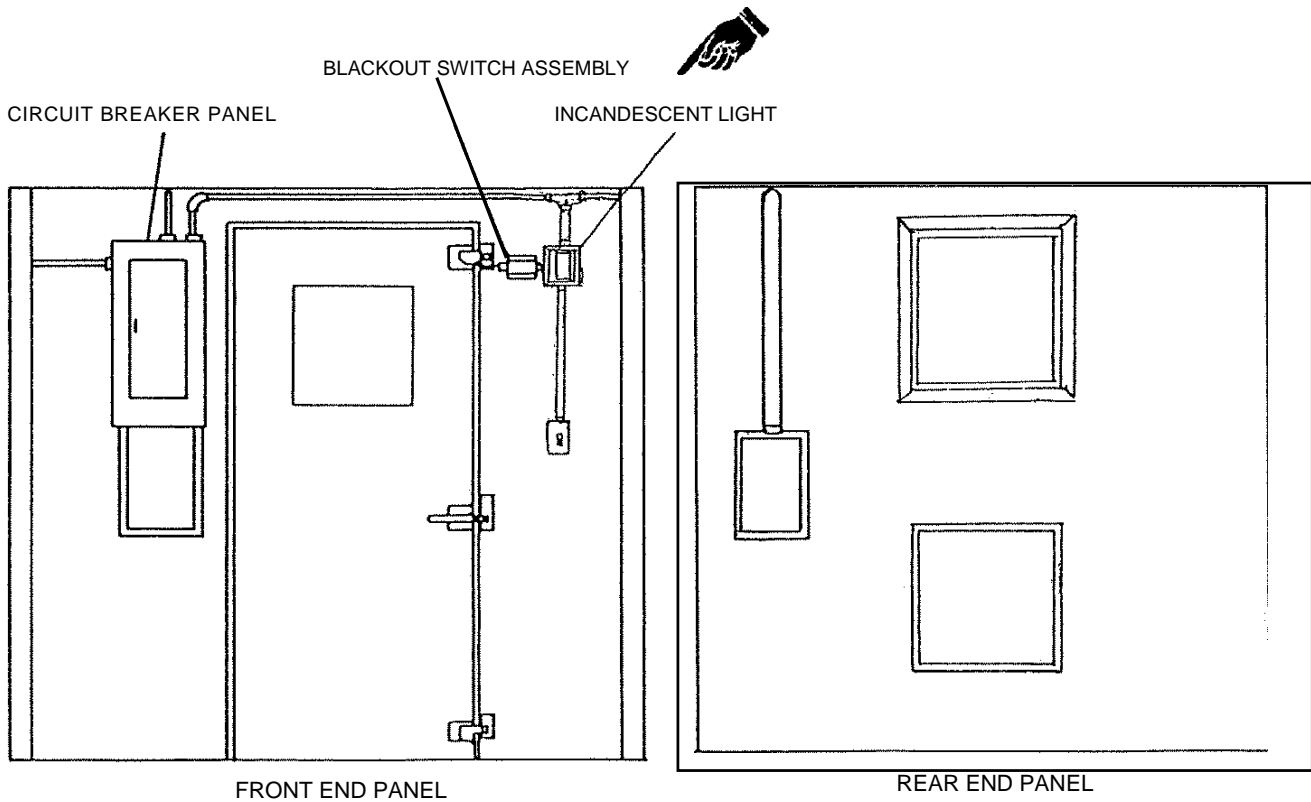

INSIDE VIEW - LOOKING AT FRONT AND REAR END PANELS

2-2. CIRCUIT BREAKER PANEL CONTROLS AND INDICATORS

Control or Indicator	Function
----------------------	----------

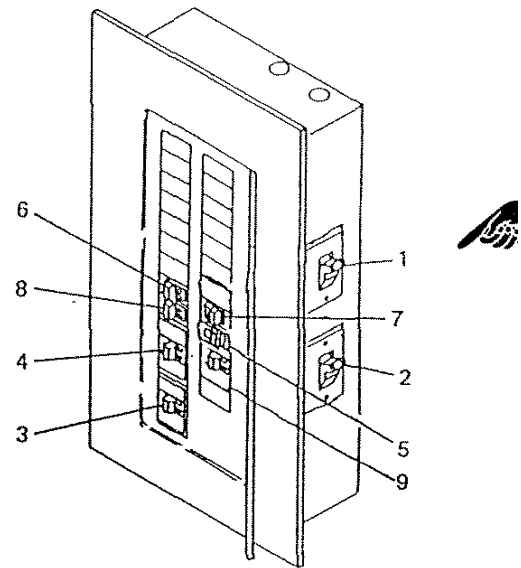
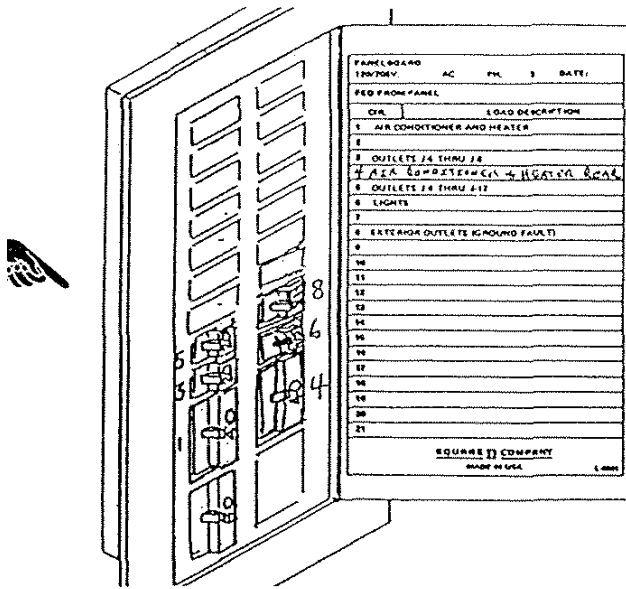

1 Blackout override switch

In ON position, overrides door activated blackout switch mounted on front end panel adjacent to personnel door. During blackout conditions, must be in OFF position. Circuit protected against overload by circuit breaker.

2 Incandescent light switch

In ON position, turns on wall mounted incandescent light. In OFF position, turns off wall mounted incandescent light. Circuit protected against overload by circuit breaker.

3 Main circuit breaker

In ON position, delivers electrical power to individual circuit breakers. In OFF position, turns off all electrical power in shelter.

4 Circuit breaker

Provides overload protection for heater/ac supply receptacle mounted on power entry panel.

5 Circuit breaker

Provides overload protection for incandescent light, blackout circuit mounted on front endwall and all fluorescent lights in shelter,

2-2. (cont)

	Control or Indicator	Function
6	Circuit breaker	Provides overload protection for interior utility outlets mounted on one sidewall.
7	Circuit breaker	Provides overload protection for ground fault interrupter utility outlet mounted on power entry panel.
8	Circuit breaker	Provides overload protection for interior utility outlets mounted on one sidewall.
9	Circuit breaker	Provides overload protection for air conditioner heater on rear end panel.

2-3. FRONT END PANEL MOUNTED CONTROLS AND INDICATORS

	Control or Indicator	Function
1	Door activated blackout switch	During blackout conditions it turns off all lights in shelter when front personnel door is opened. To override operation of this switch, the circuit breaker panel mounted blackout override switch must be in ON position. Circuit protected against overload by circuit breaker.
2	Ceiling lights switch	In ON position, turns on three fluorescent lights in shelter. In OFF position turns off three fluorescent lights. Circuit protected against overload by circuit breaker.

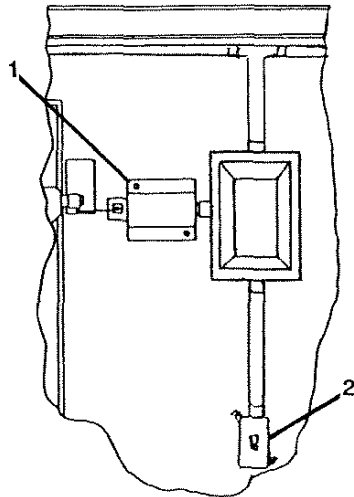

Section II OPERATOR'S PREVENTIVE MAINTENANCE CHECKS AND SERVICES (PMCS)

2-5. GENERAL. For the shelter to be ready for use at all times, it must be inspected systematically so that defects may be discovered and corrected before they result in serious damage or failure.

a. Before you operate. Always keep in mind the CAUTIONS and WARNINGS. Perform your "B-before" PMCS.

b. While you operate. Always keep in mind the CAUTIONS and WARNINGS. Perform your "D-during" PMCS.

c. Monthly. Always keep in mind the CAUTIONS and WARNINGS. Perform your "M-monthly" PMCS.

d. If your equipment fails to operate, troubleshoot with proper equipment. Report deficiencies as follows: Users report in accordance with DA PAM 738-750.

2-6. SPECIAL INSTRUCTIONS. The following actions apply while performing your PMCS:

a. Stop operation immediately if deficiency is noted during operation which would damage the equipment.

b. Defects discovered during operation of the equipment should be noted for future correction to be made as soon as operation has ceased.

2-7. PREVENTIVE MAINTENANCE CHECKS AND SERVICES TABLE. The following is a list of all PMCS to be performed by the operator.

NOTE

If the equipment must be kept in continuous operation, check and service only those items that can be checked and serviced without disturbing operation. Make the complete checks and services when the equipment can be shut down. Inspect shelter for leaks.

Table 2-1. Operator's Preventive Maintenance Checks and Services

Item No.	Interval			Item to be Inspected	Procedures Check for and have repaired or adjusted as necessary	For readiness reporting, equipment is Not Ready/ Available if :
	B - Before	D - During	M - Monthly			
ELECTRICAL SYSTEM						
1	•	•	•	Circuit break panel assembly	Inspect for damage to door and panel	Circuit panel damaged
2	•	•	•	Panel wiring	Inspect for damage or disconnection	Wiring damaged or disconnected
3	•	•	•	Light switches	Inspect for operation	Lights not operating
4	•	•	•	Circuit breakers	Inspect for operation, condition, and security	Circuit breakers not operating
5	•	•	•	Power entry panel assembly	Inspect for damage to panel	Panel damaged
6	•	•	•	ECU power entry panel assembly	Inspect for damage to panel	Panel damaged
7	•	•	•	Receptacles	Inspect for operation, condition, and security	Receptacles not operating
8	•	•	•	Terminals/Connectors	Inspect for operation, condition, and security	Terminals/Connectors not operating
9	•	•	•	Area light assembly	Inspect for operation	Light not operating
10	•	•	•	Incandescent light assembly	Inspect for operation	Light not operating
11	•	•	•	Ceiling lights	Inspect for operation	Lights not operating
12	•	•	•	Receptacle outlets	Inspect for operation	Outlets not operating
13	•	•	•	Blackout switch	Inspect for operation	Switch not operating
14	•	•	•	Raceway assembly	Inspect for damage or disconnection	ECU power entry panel not operating

Table 2-1. Operator's Preventive Maintenance Checks and Services (cont)

Item No.	Interval			Item to be Inspected	Procedures Check for and have repaired or adjusted as necessary	For readiness reporting, equipment is Not Ready/ Available if :
	B	D	M			
DOOR ASSEMBLIES						
15	•		•	Personnel doors	Inspect for operation, condition, and security	Door not operating, damaged, or insecure
16	•		•	Door vents	Inspect for operation and condition	Vent not operating or damaged
17	•		•	Door lock assemblies	Inspect for operation and condition	Lock assembly not operating or damaged
18	•		•	Door stop assemblies	Inspect for operation and condition	Stop assembly not operating or damaged
CONTAINER LIFT JACK ASSEMBLIES						
19	•		•	Container lift jack assemblies	a. Inspect for sinking into ground if shelter not level (check frequently during rainy conditions). b. Inspect for condition and security	a. Shelter not level b. Jacks damaged or insecure
FIXED PANEL ASSEMBLIES						
20	•		•	Front endwall panel	a. Inspect skin surface for paint damage, corrosion, cracks, or punctures b. Inspect security of upper mobilizer fitting	a. Panel skin corroded, cracked, or punctured b. Upper mobilizer fitting insecure
21	•		•	Level assemblies	Inspect for condition and security	Level assembly damaged or insecure

Table 2-1. Operator's Preventive Maintenance Checks and Services (cont)

Item No.	Interval			Item to be Inspected	Procedures Check for and have repaired or adjusted as necessary	For readiness reporting, equipment is Not Ready/ Available if :
	B	D	M			
22	•		•	Folding steps	Inspect for condition, and security	Folding steps damaged or insecure
23	•		•	ECU intake panel	Inspect skin surface for paint damage, corrosion, cracks, or punctures	Panel skin corroded, cracked, or punctured
24	•		•	ECU return panel	Inspect skin surface for paint damage, corrosion, cracks, or punctures	Panel skin corroded, cracked, or punctured
25	•		•	Closeout Panels	Inspect skin surface for paint damage, corrosion, cracks, or punctures	Panel skin corroded, cracked, or punctured
26	•		•	Rear endwall panel	a. Inspect skin surface for paint damage, corrosion, cracks, or punctures b. Inspect security of upper mobilizer fittings	a. Panel skin corroded, cracked, or punctured b. Upper mobilizer fittings insecure
27	•		•	Sidewall panels	Inspect skin surface for paint damage, corrosion, cracks, or punctures	Panel skin corroded, cracked, or punctured
28	•		•	Roof panel	a. Inspect skin surface for paint damage, corrosion, cracks, or punctures b. Inspect roof hand hold for condition and security	a. Panel skin corroded, cracked, or punctured b. Hand hold damaged or insecure

Table 2-1. Operator's Preventive Maintenance Checks and Services (cont)

Item No.	Interval			Item to be Inspected	Procedures Check for and have repaired or adjusted as necessary	For readiness reporting, equipment is Not Ready/ Available if :
	B	D	M			
29	•		•	Stowage brackets	c. Inspect strike plates for security and condition Inspect for condition and security	c. Strike plate loose or damaged Stowage brackets damaged or insecure
30	•		•	Floor panel	Inspect skin surface for paint damage, corrosion, cracks, or punctures	Panel skin corroded, cracked, or punctured
FRAME ASSEMBLY						
31	•		•	Corner post and ISO fitting assembly	Inspect for condition and security	Corner post or ISO fitting damaged or insecure
MISCELLANEOUS COMPONENTS						
32	•		•	Equipment container	Inspect for condition and completeness	Equipment container damaged or incomplete
33	•		•	Storm configuration components	Inspect for condition and completeness	Storm configuration components damaged or incomplete

CAUTION

Skin surfaces that are punctured/damaged will allow water entry into honeycomb panel. All punctures/holes of damaged areas must be covered immediately pending permanent repair.

Section III. SETUP OF SHELTER

2-8. PREPARATION FOR USE.

Select a site that:

- Has reasonable maneuvering area for vehicles that will be used for hauling or hoisting shelter.
- The terrain is firm, well drained, and relatively free of surface rocks or stones.
- The slope of the terrain does not exceed 18 inches (45.7 cm) over the projected floor area of the expanded shelter.

2-9. SHELTER INVENTORY CHECKS.

- a. Expandable shelters are shipped uncrated.
- b. Inspect shelter for damage incurred during shipment. If shelter has been damaged, report damage on SF361, Transportation Discrepancy Report.
- c. Check equipment against packing list to see if shipment is complete. Report all discrepancies in accordance with instructions of DA PAM 738-750.
- d. Inspect shelter (stowed mode) in accordance with paragraph 2-9.

2-10. SHELTER INSPECTION CHECKLIST

LOCATION	ITEM	ACTION
1. Front endwall	<ol style="list-style-type: none"> a. Power entry panel b. Identification and instruction plates 	<p>Inspect connectors for damage.</p> <p>Check for legibility or missing plates.</p>

2-10. (cont)

LOCATION	ITEM	ACTION
	c. Personnel door	Check for security and condition of door, locks, seals, and vent
	d. Upper mobilizer fittings	Check for security and condition
	e. Folding steps	Check for security and condition
	f. Components	Inspect for missing, bent, or damaged components.
	g. Skin	Inspect skin surface for paint damage, corrosion, cracks, or punctures.
2. Fixed Roof	a. Roof handhold	Check for security and operation
	b. Upper ISO fittings	Inspect fittings for damage.
	c. Skin	Inspect skin surface for paint damage, corrosion, cracks, or punctures.
	d. Strike plates	Check for security and condition.
	e. Raceways	Inspect raceways for damage
3. Fixed endwall	a. CSC Plate	Check for legibility or missing plate
	b. Power Entry Panel	Inspect connectors for damage.
	c. Upper mobilizer fitting	Check for security and condition.
	d. Components	Inspect for missing, bent, or damaged components.
	e. Skin	Inspect skin surface for paint damage, corrosion, cracks, or punctures.

2-10. (cont)

LOCATION	ITEM	ACTION
4. Floor/base frame	a. Lower mobilizer fittings	Check for security and condition
	b. Lower ISO fittings	Inspect fittings for damage.
	c. Frame edge and fork lift openings	Inspect for damage.
5. Floor panel	Skin	Inspect skin surface for paint damage, corrosion, cracks, or punctures.
6. Corner posts	Components	Inspect for missing, bent, or damaged components.

2-11. SHELTER HANDLING

WARNING

Do not use handling equipment with capacity of less than gross weight of system. Do not allow shelter to swing back and forth when suspended. Failure to observe this WARNING may result in damage to equipment or severe injury or death to personnel.

NOTE

Dollyset M832 mobilizer used only if gross weight of shelter system is 10,000 pounds (4546 Kg) or less.

Dollyset XM1022 or hoisting sling (with cable breaking strength of 35,000 pounds) used if gross weight of shelter system is over 10,000 pounds (4546 kg).

When using fork lift, make sure it has a minimum tine length of six feet. Use inner slots for fork lifting an empty shelter only.

Use 20-foot container lift sling (bottom lift, type II, with a 20 long ton safe working load) with aluminum spreader, Appendix D.

2-11. (cont)

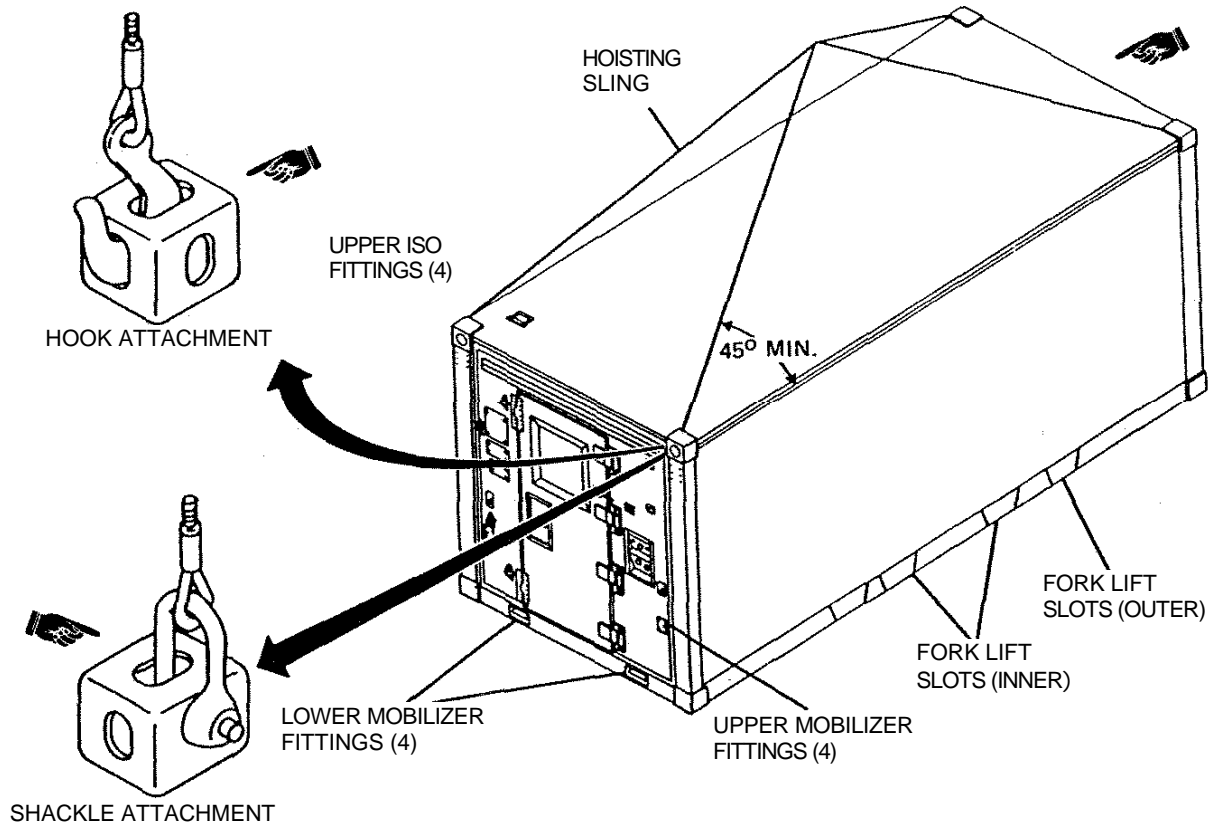

a. Hoisting from upper ISO fittings.

CAUTION

Do not attach hoisting sling or ISO lifting device to handling equipment in such a manner that angle between hoist line and shelter is less than 45 degrees. Any angle less than 45 degrees will cause an excessive strain which could damage shelter.

- (1) Attach hoisting sling to crane or equivalent and four upper ISO fittings.
- (2) Hoist shelter and position to desired location.

b. Hoisting from lower ISO fittings.

- (1) Attach ISO lifting device to crane or equivalent and four lower ISO fittings.

2-11. (cont)

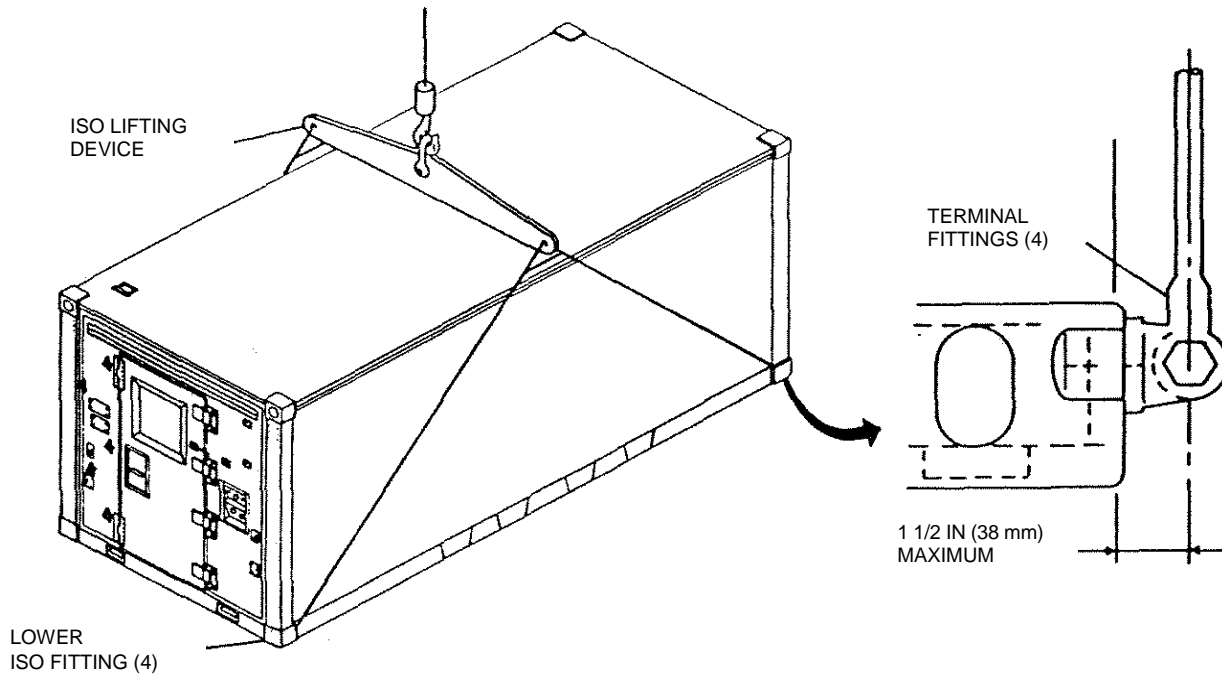

(2) The ISO lifting device should contact four lower ISO fittings only and not make any other contact with shelter.

(3) Terminal fittings shall be installed so that lifting forces are exerted not more than 1-1/2 in. (38 mm) away from ISO fittings.

(4) Hoist shelter and position to desired location.

c. Fork lifting from fork lift slots in base frame.

(1) Fork lift arms shall be at least 6 ft (1.8 m) long.

(2) Use care when inserting fork lift arms in fork lift slots.

(3) Use inner slots for fork lifting an empty shelter only.

(4) Use outer slots for fork lifting shelter with maximum payload.

d. Dollyset lifting from mobilizer fittings.

(1) Separate Dollyset sections and prepare for use observing all recommendations to Dollyset technical manual. Refer to TM 9-2330-275-14&P and TM 9-2330-379-14&P.

(2) Position Dollyset sections at ends of shelter adjacent to mobilizer fittings at shelter endwalls.

2-11. (cont)

(3) Position Dollyset brackets to connect with shelter mobilizer fittings and secure Dollyset to shelter.

(4) Operate Dollyset according to Dollyset technical manual to raise shelter to towing height.

(5) Connect towing equipment to Dollyset tow bar.

(6) When shelter is in desired position, operate Dollyset to lower shelter and remove Dollyset sections.

e. Dollyset lifting from ISO fittings.

(1) Separate Dollyset sections and prepare for use observing all recommendations of Dollyset technical manual.

(2) Position Dollyset sections at ends of shelter adjacent to ISO fittings at shelter endwalls.

(3) Position Dollyset brackets to connect with shelter ISO fittings and secure Dollyset to shelter.

(4) Operate Dollyset according to Dollyset technical manual to raise shelter to towing height.

(5) Connect towing equipment to Dollyset tow bar.

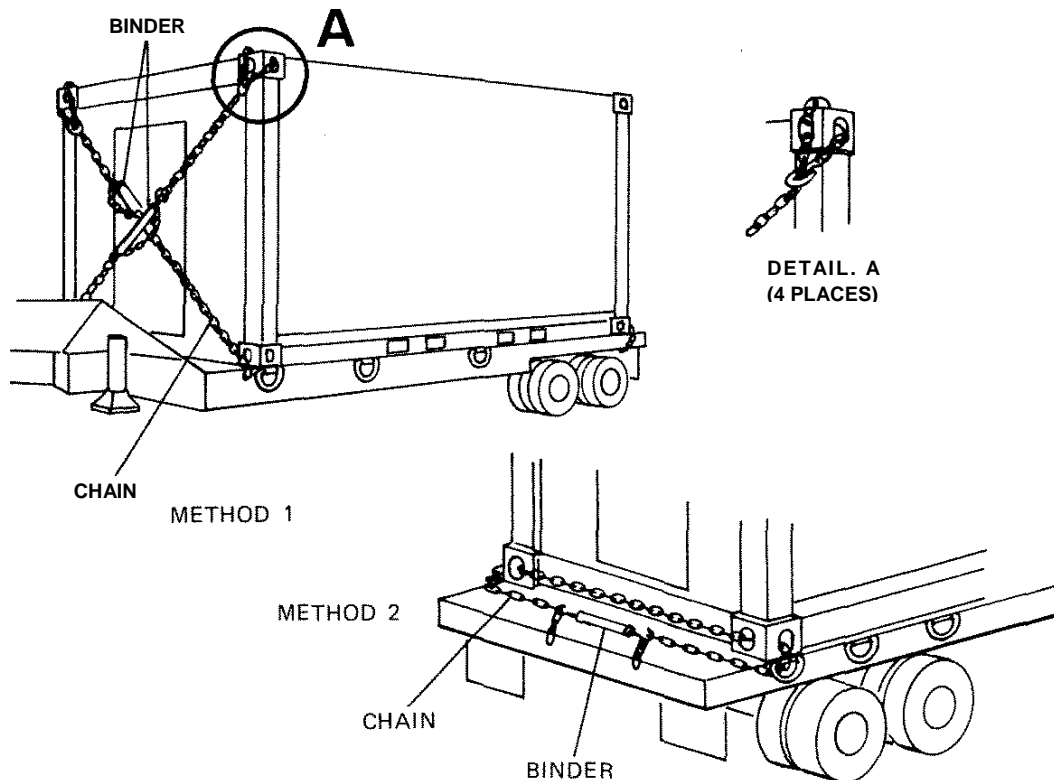

2-11. (cont)

(6) When shelter is in desired position, operate Dollyset to lower shelter and remove Dollyset sections.

f. Trailer or flatbed transporting.

(1) Using four 14-foot chains and four binders, secure shelter to trailer or flatbed as shown in Method 1. (Refer to page 2-15).

(2) Using two 20-foot chains and two binders or four 6-foot chains and two binders, secure shelter to trailer or flatbed as shown in Method 2. (Refer to page 2-15).

g. Railroad transporting.

(1) Place floor timbers along the front and rear of the shelter contacting lower ISO fittings.

NOTE

Make sure timber is new and has no structural weakness.

(2) Tie the shelter down to the retaining brackets on the railroad car with 1/2-inch diameter wire rope and turn buckles.

(3) Place 8-inch by 8-inch blocking timbers on the railroad car floor with the edge grain laid flatwise.

(4) Place at least four 4-inch by 5-inch vertical post timbers with edge grain oriented fore and aft at each end of the shelter.

(5) Bolt the ends of the floor timbers to the vertical post timbers using 3/4-inch diameter bolts.

(6) Spike or nail the vertical post timbers through the retaining brackets on the railroad car to prevent vertical movement.

2-12. LOCATION OF IDENTIFICATION AND INSTRUCTION PLATES. The following figures provide location and contents of identification and instruction plates for the shelter.

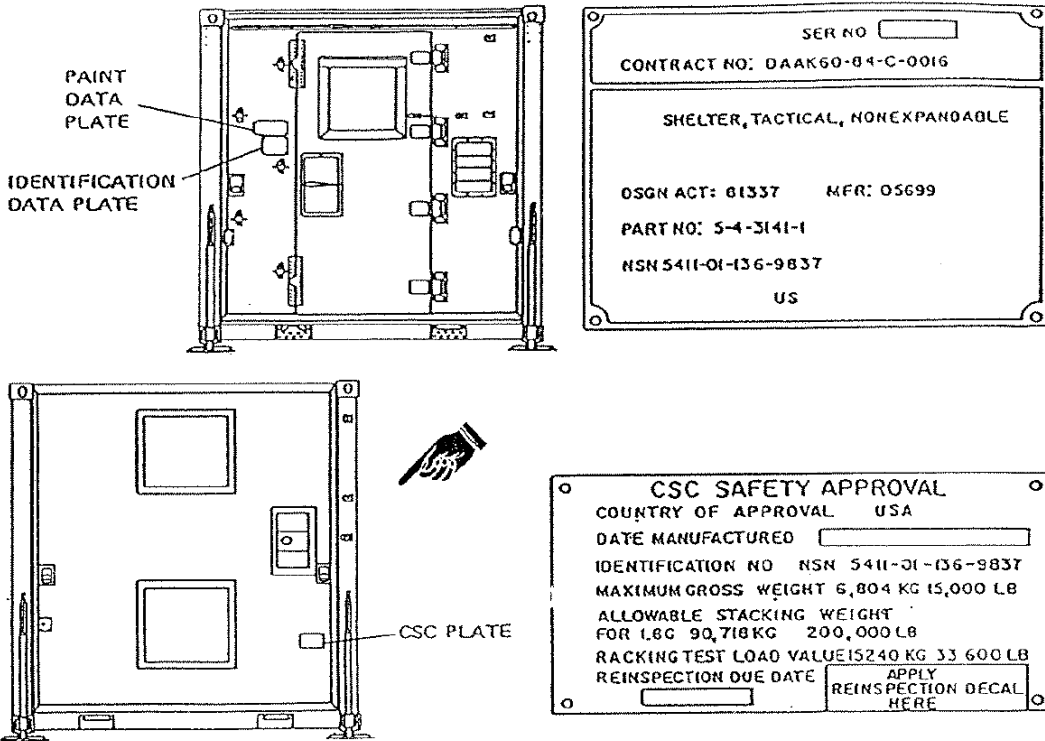

	PAINT TYPE	MIL SPEC COLOR	COLOR CODE FED-STD-595	NSN
INTERIOR PAINT	URETHANE ALIPHATIC ISOCYANATE	MIL-C-83286 GLOSS WHITE	17925	8010-00-181-8282
EXTERIOR PAINT	ALIPHATIC POLYURETHANE	MIL-C-46168 SAND		
PRIMER	EPOXY POLYAMIDE	MIL-P-23377		8010-00-142-9279
FLOOR PRIMER	ZINC CHROMATE	TT-P-1757		8010-00-515-2208
FLOOR PAINT	WALKWAY COMPOUND	MIL-W-5044 TYPE I GRAY	26251	

(NSN 5411-01-136-9837)

2-13. LEVELING SHELTER

NOTE

Four personnel are required to perform the following procedures.

- a. Remove four container lift jacks from inside of sidewall panel and front personnel door, by turning locking handle to loosen jack attachment insert and removing safety pin.
- b. Position jacks at each corner of shelter.

NOTE

Stencil on jack indicates handle rotation to raise or lower jack.

- c. Rotate handle to raise jack until insert will enter lower ISO fitting and upper jack attachment engages jack support bracket on corner post.
- d. Turn locking handle to rotate insert in ISO fitting. Install safety pin.
- e. Repeat steps c and d at three remaining corner posts.

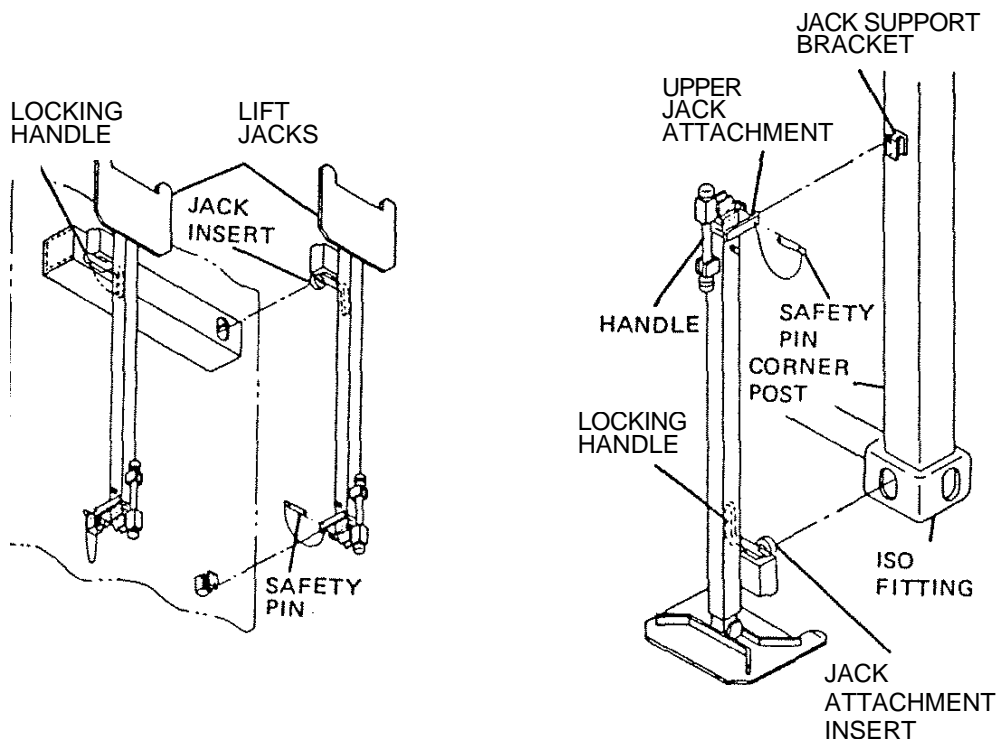

2-13. (cont)

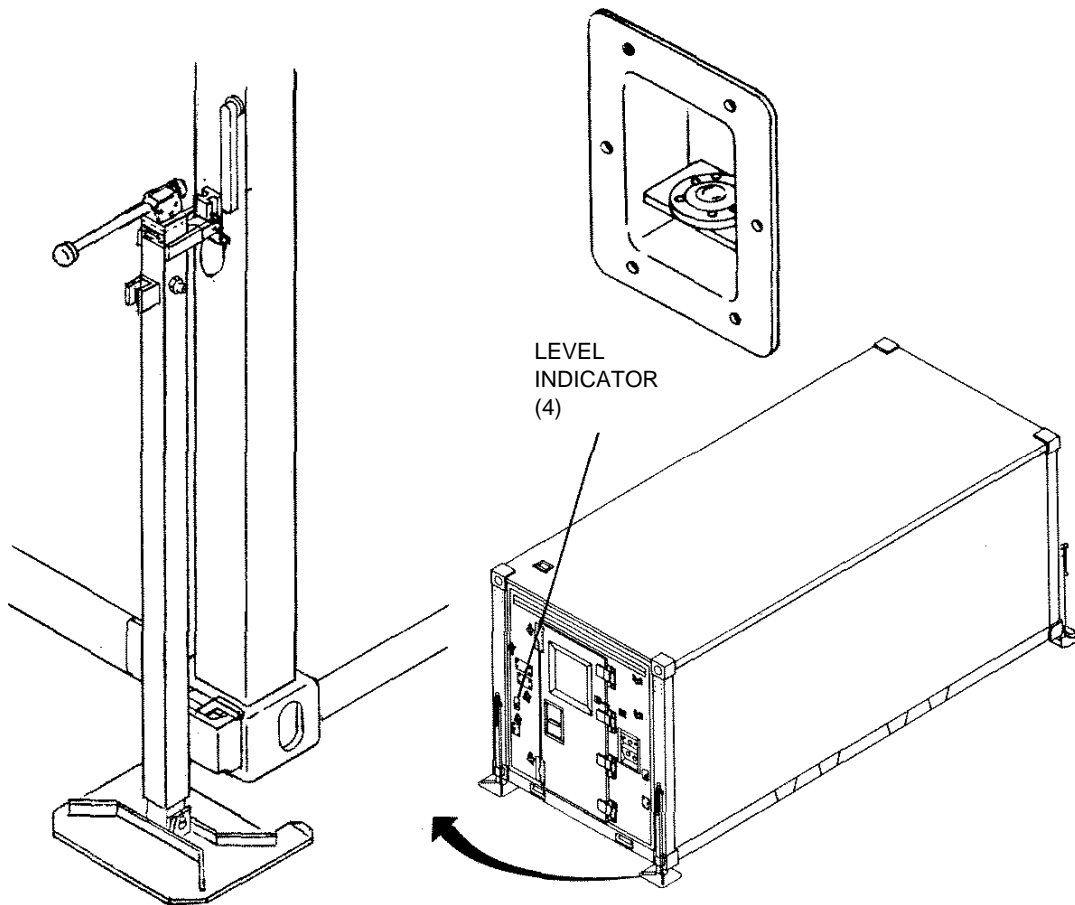

f. Raise all jacks simultaneously at each corner of shelter to prevent excessive strain on jacks or shelter.

NOTE

The shelter shall be raised a minimum of 3 inches (7.6 cm) off ground.

g. Watch level indicators at each corner and adjust jacks as needed in order to level shelter.

2-14. AREA LIGHT INSTALLATION

- a. Loosen wingnuts and remove area light from stowage location inside shelter on front personnel end panel.

NOTE

Do not remove wingnuts from screws.

- b. Remove bulb from equipment container and screw bulb into light socket.
- c. Install the area light on the front or rear personnel endwall by mating the headed end of the mounting screws with the brackets provided.

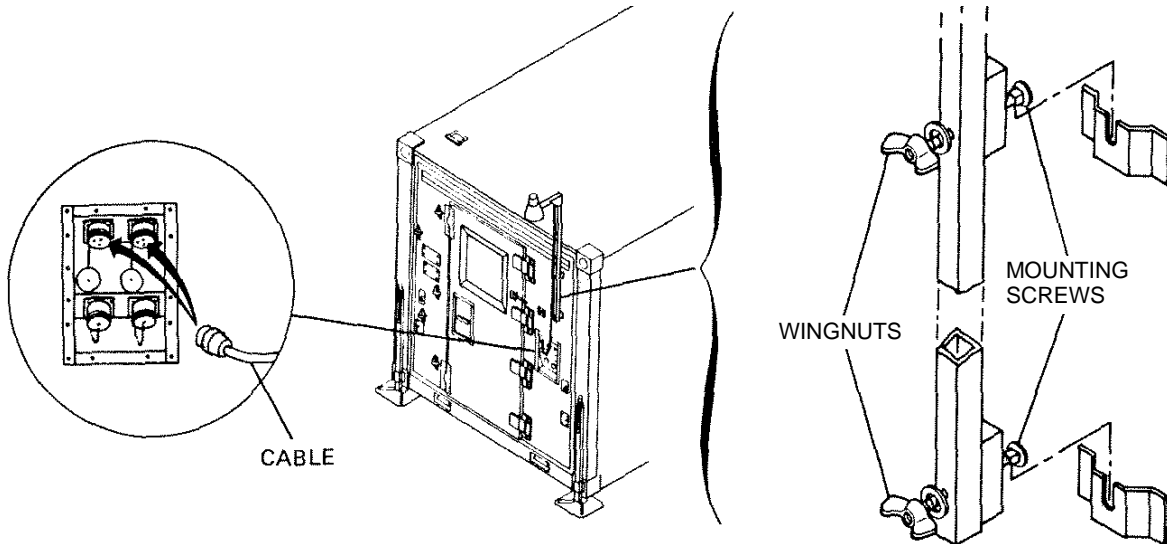

- d. Secure the area light to the mounting brackets by tightening the two wingnuts.

NOTE

When the area light is installed at the rear personnel end of shelter the cable is routed over the top of the shelter. The excess cable slack should be neatly coiled on the area light post so that it does not present a hazard to personnel.

- e. Connect cable into J3 or J4 connectors on the power entry panel.

2-15. EXTERNAL CONNECTIONS

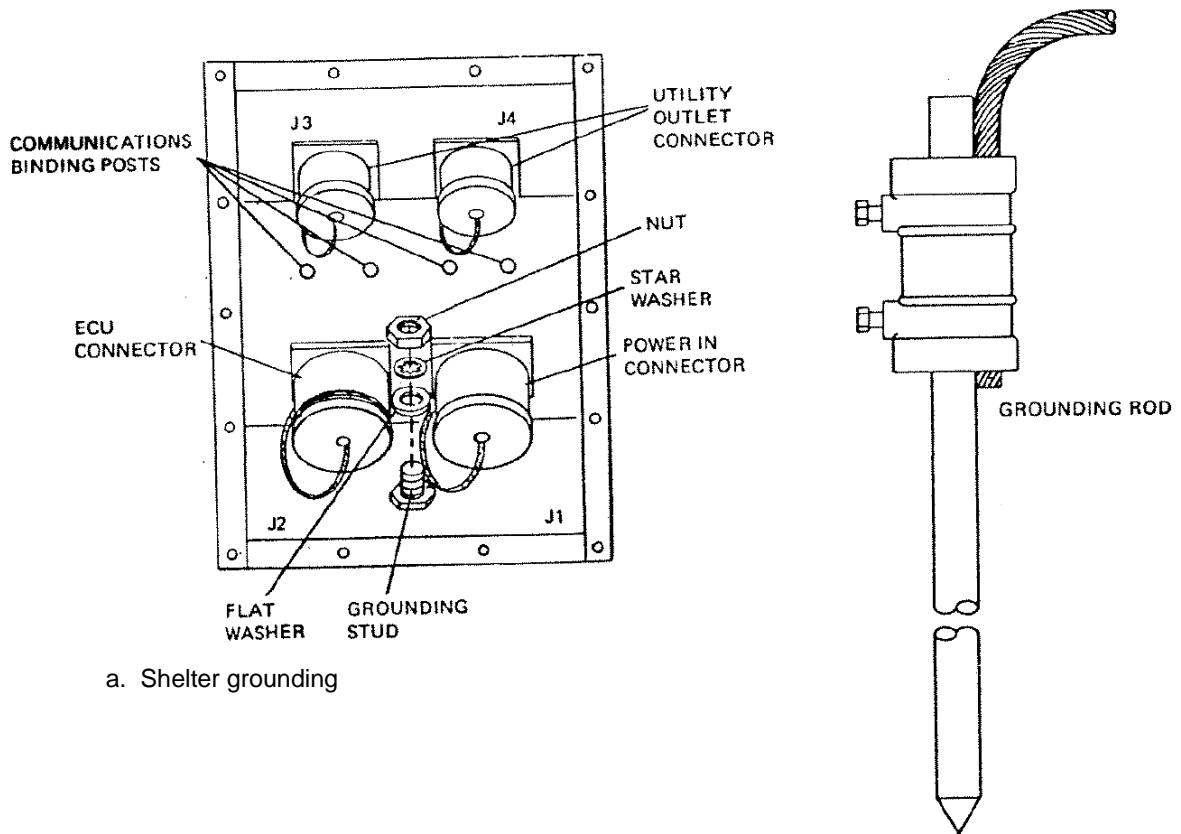

a. Shelter grounding

WARNING

DEATH ON CONTACT
may result if shelter is used without grounding it
first.

NOTE

Shelter is grounded through externally connected power supply. Additional grounding, depending on local conditions, may be installed by utilizing optional grounding rod, Appendix D. Consult a qualified electrician for proper grounding procedures required for the surrounding soil conditions.

- (1) Drive ground rod into earth at a suitable location that permits ground cable attached to rod to reach ground stud on power entry panel.
- (2) On power entry panel remove nut, star washer, and flat washer on stud.
- (3) Connect ground cable connector to stud and secure with washer, star washer, and nut.
- (4) Check all connections for security.

2-15. (cont)

b. Input power connection

WARNING

Do not attempt connection of live line to power entry panel. Deactivate power source or generator before procedure.

CAUTION

Power supply shall be 120/208 Vac, 4 wire with ground for the NQOB Model or 4 wire with 4 grounds for the NQOD Model or damage to equipment will result.

- (1) Turn all circuit breakers to OFF position.

NOTE

Make certain that power entry panel and power supply cable are terminated with same type of connector.

- (2) Connect power supply cable to power entry panel at connector (J1).
- (3) Turn MAIN circuit breaker to ON position and observe any unusual conditions.
- (4) Turn remaining circuit breakers to ON position one at a time and observe any unusual conditions.

c. ECU Connection.

- (1) Turn CB1 to OFF position.
- (2) Connect ECU supply cable to connector (J2).
- (3) Turn CB1 to ON position and observe for any unusual conditions.

Section IV. OPERATION UNDER USUAL CONDITIONS

NOTE

If equipment fails to operate, refer to troubleshooting procedures in Chapter 3.

2-16. OPERATING INSTRUCTIONS. Due to the limited operating capability of shelter, operating instructions are limited to operation of circuit breakers and switches for the purpose of providing power to lights, outlets, fan, and externally connected environmental control unit (ECU), if installed.

Section V. OPERATION UNDER UNUSUAL CONDITIONS

2-17. GENERAL. This section provides instructions for operation of the shelter in unusual weather conditions. Operation during blackout conditions is also provided.

2-18. OPERATION IN RAIN AND/OR MUD

- a. Provide adequate drainage ditch to prevent standing water around shelter area.
- b. Check leveling jacks frequently for sinking; level shelter as required by adjusting container lift jacks.
- c. Close and secure all doors in shelter.
- d. Check seals for proper placement and compression.

2-19. OPERATION IN SNOW, ICE OR EXTREME COLD

WARNING

In extreme cold, do not touch metal parts with bare hands.
Severe skin damage may result.

- a. Remove snow routinely with a soft bristle brush, broom, or equivalent.
- b. Insure ECU is properly connected to shelter.
- c. Keep all doors and vents closed.

2-19. (cont)

NOTE

Fluorescent lights have a delay time in coming on at temperatures of 0°F and below.

2-20. OPERATION IN HIGH WINDS.

NOTE

Two personnel are required to perform the following procedure.

a. To install the storm configuration kit (tie-down installation which is found in the equipment container), use the following items:

- (1) Ground anchor assembly.
- (2) Driving rod.
- (3) Holding handle.
- (4) Driving head.

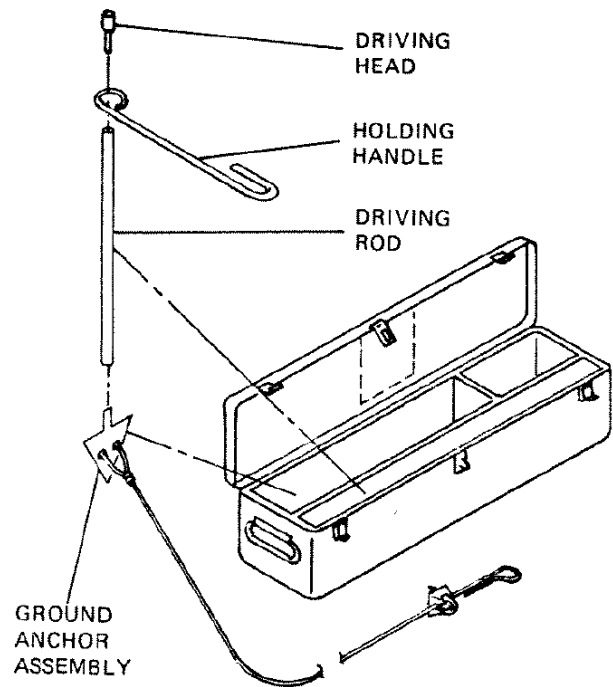

WARNING

Safety glasses must be worn by personnel when installing ground anchors.

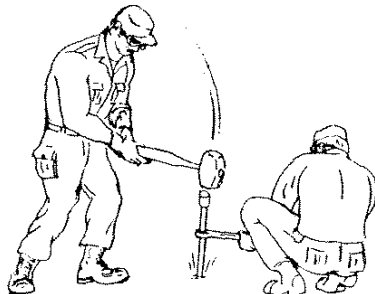

2-20. (cont)

b. One person shall support driving rod with holding handle, while second person drives ground anchor into ground using 12-pound sledge hammer, Appendix D.

c. Drive each of four loop and clamp ground anchors into ground approximately 3 feet (91.5 cm) deep, and as close as possible to the shelter attaching points, at locations indicated below.

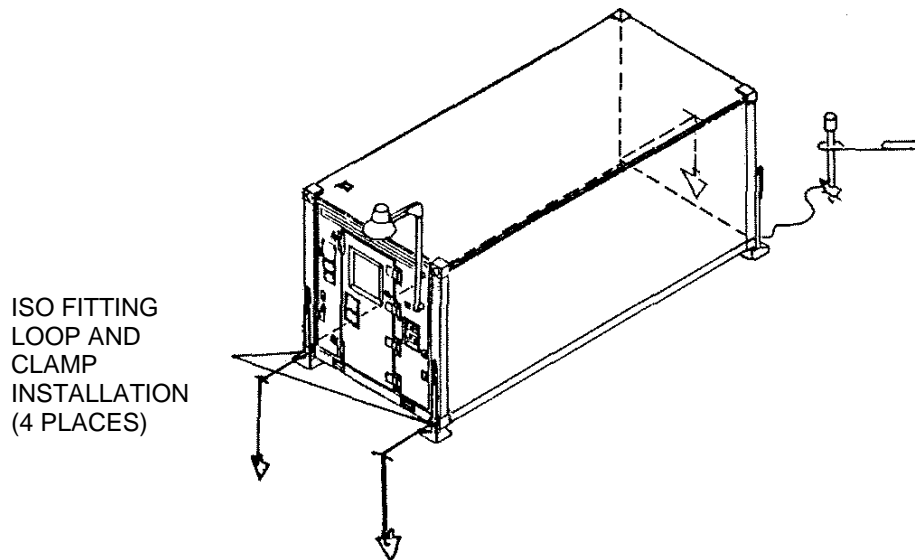

- d. Set each ground anchor by forming a loop in cable end and secure loop with clamp.
- e. Insert driving rod through loop and pull up sharply to ensure anchor is set into ground.

NOTE

This setting of the anchor is required to turn the anchor in the ground so that it develops maximum holding power.

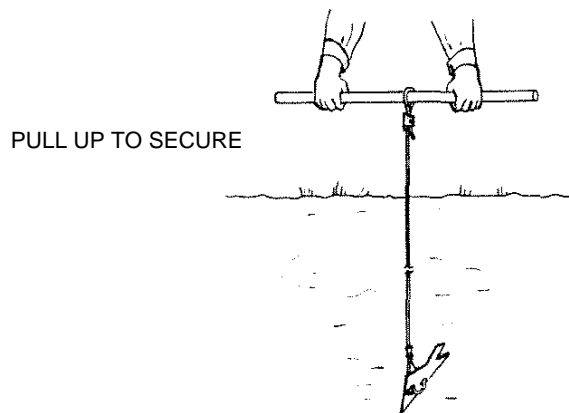

2-20. (cont)

- f. Remove clamp, loop cable at four places as shown. Replace clamp, pull cable tight and tighten clamp nuts.

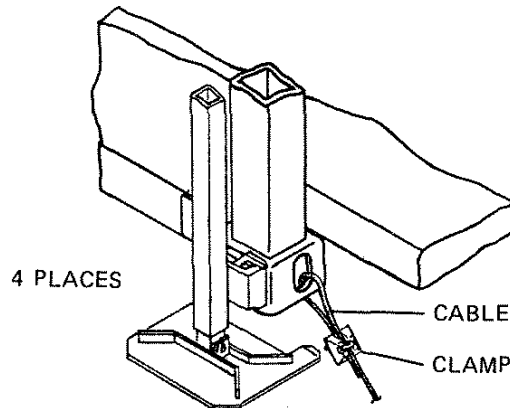

NOTE

When moving shelter, disassemble storm configuration kit and cut cable as close to ground as possible. Discard cable components.

2-21. OPERATION DURING BLACKOUT CONDITIONS

NOTE

During blackout condition, enter and leave shelter through front personnel door only. Do not operate exterior area light.

- a. Activate all interior lights and check from 25 feet (7.6 meters) away to ensure no light is visible.
- b. Place blackout override switch to OFF position.

NOTE

Blackout override switch must remain in OFF position for duration.

CHAPTER 3

OPERATOR MAINTENANCE INSTRUCTIONS

Section I. TROUBLESHOOTING PROCEDURES

3-1. GENERAL. This section contains operator troubleshooting information for locating and correcting common malfunctions which may develop in shelter.

WARNING

HIGH VOLTAGE

exists in the electrical system of this equipment

DEATH ON CONTACT

may result if personnel fail to observe safety precautions.

a. Paragraph 3-2 lists common malfunctions which you may find during operation or maintenance of shelter electrical system or components. You should perform inspections and corrective actions in order listed.

b. All malfunctions that may occur and all inspections and corrective actions may not be listed. If a malfunction is not listed or is not corrected, notify your supervisor.

c. When troubleshooting operation of shelter electrical system, all switches and circuit breakers shall be placed in OFF positions with power connected.

d. The operator is limited to setting circuit breakers (ON/OFF), setting light assemblies in place, and replacing light bulbs.

3-2. OPERATOR TROUBLESHOOTING

MALFUNCTION

TEST OR INSPECTION

CORRECTIVE ACTION

1. NO POWER DISTRIBUTION TO SHELTER.

Step 1. Check that outside power is properly connected to service entrance connector on power entry panel and check general condition of cable and connectors.

a. Make proper power connection.

b. Check for defective cable or connectors.

3-2. (cont)

MALFUNCTION

TEST OR INSPECTION

CORRECTIVE ACTION

Step 2. Check and reset main circuit breaker, and check outside power.
Notify organizational maintenance.

2. INCANDESCENT LIGHT FAILS TO COME ON.

Step 1. Check and reset circuit breaker.

Step 2. Check visually for burned out incandescent bulb.
Change bulb. (Refer to paragraph 4-10.)

Step 3. Check operation of incandescent light switch and blackout override switch.
Notify organizational maintenance.

WARNING

In the event of lamp breakage, care must be taken in removal of broken glass fragments and white phosphorous dust that may be dispersed within fixture. Inhalation of phosphorous dust could cause serious injury.

3. ALL FLUORESCENT LIGHTS FAIL TO COME ON.

Step 1. Check operation of fluorescent light switch and blackout override switch.

Step 2. Check and reset circuit breaker.
Notify organizational maintenance.

4. ONE OR MORE FLUORESCENT LIGHTS FAIL TO COME ON.

Check visually for burned out fluorescent lamps.

- a. Turn off appropriate circuit breaker and replace lamp. (Refer to paragraph 4-11.)
- b. Turn on appropriate circuit breaker.

3-2. (cont)

MALFUNCTION

TEST OR INSPECTION

CORRECTIVE ACTION

5. NO POWER AT ONE OR MORE INTERIOR UTILITY OUTLETS.

Check and reset associated circuit breakers.

Notify organizational maintenance.

6. NO POWER AT ONE OR BOTH EXTERIOR UTILITY OUTLETS.

Check and reset circuit breaker.

Notify organizational maintenance.

7. AREA LIGHT FAILS TO COME ON.

Step 1. Check and reset circuit breaker.

Step 2. Check visually for burned out bulb.

Change bulb. (Refer to para 4-9).

Notify organizational maintenance.

8. NO POWER AT HEATER/AC SUPPLY.

Step 1. Check that outside power is properly connected to service entrance connector on power entry panel, and check general condition of cable and connectors.

a. Make proper power connection.

b. Check for defective cable or connectors.

Step 2. Check and reset circuit breakers.

Notify organizational maintenance.

Section II. OPERATOR MAINTENANCE PROCEDURES

3-3 GENERAL. Authorized maintenance procedures to be performed by operator include replacement of area light assembly, replacement of light bulbs, closeout panels, ECU intake panel, ECU return panel, container lift jack assemblies, and storm configuration components.

3-4. AREA LIGHT ASSEMBLY REPLACEMENT

This task covers:

- a. Removal
 - b. Installation
-

WARNING

Disconnect power of circuit involved by setting circuit breaker to off position.

REMOVAL

1. Place circuit breaker CB8 to off position. (Refer to page 2-2 for location.)

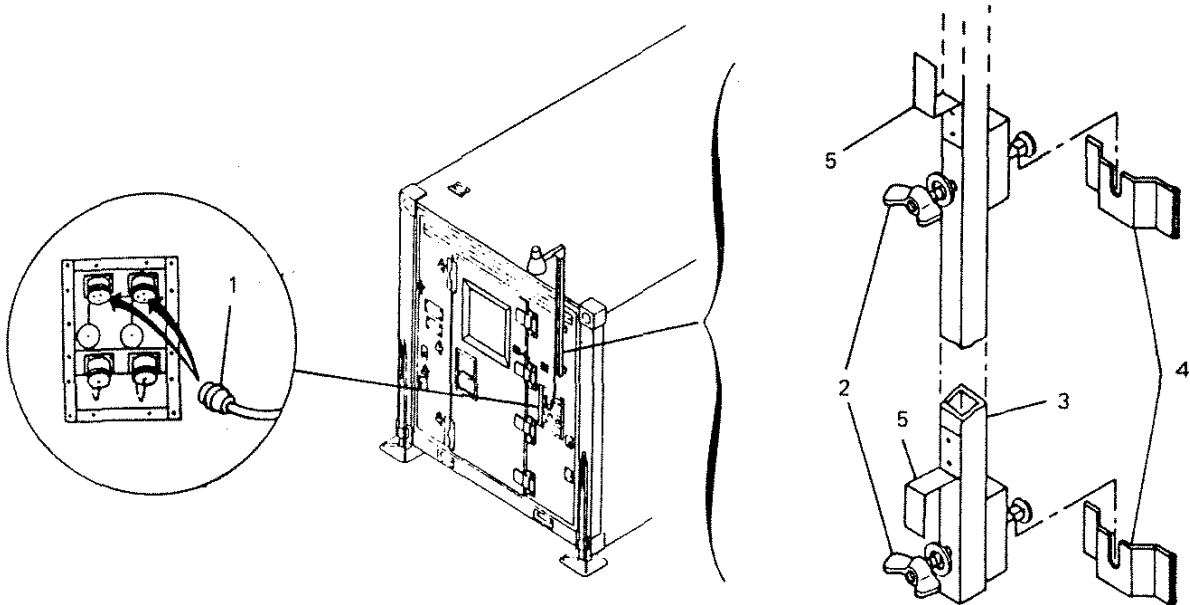

3-4. (cont)

2. Disconnect area light assembly connector (1) from power entry panel.
3. Loosen two wingnuts (2) and lift area Light assembly (3) from two brackets (4) on shelter.
4. Coil cable on brackets (5) on light post.

INSTALLATION

1. Position post of area light assembly (3) in two brackets (4) on shelter and tighten two wingnuts (2) to secure light to shelter.
2. Connect area light assembly connector (1) to power entry panel.
3. Place circuit breaker CB8 to on position.

3-5. CLOSEOUT, ECU INTAKE, AND ECU RETURN PANELS REPLACEMENT

This task covers:

- a. Removal
 - b. Installation
-

INITIAL SETUP

Standard Tools

General mechanics tool kit

Personnel - 2

References

Applicable ECU manual.

REMOVAL

1. If environmental control unit (ECU) panels are installed and ECU is operating, shut down ECU. (Refer to applicable ECU manual.)
2. Disconnect ECU ducts. (Refer to applicable ECU manual.)

Closeout Panels

3. Inside shelter, loosen four captive screws (1) and remove closeout panel (2).

ECU Intake Panel

Inside shelter, loosen four captive screws (3) and remove ECU intake panel (4).

3-5. (cont)

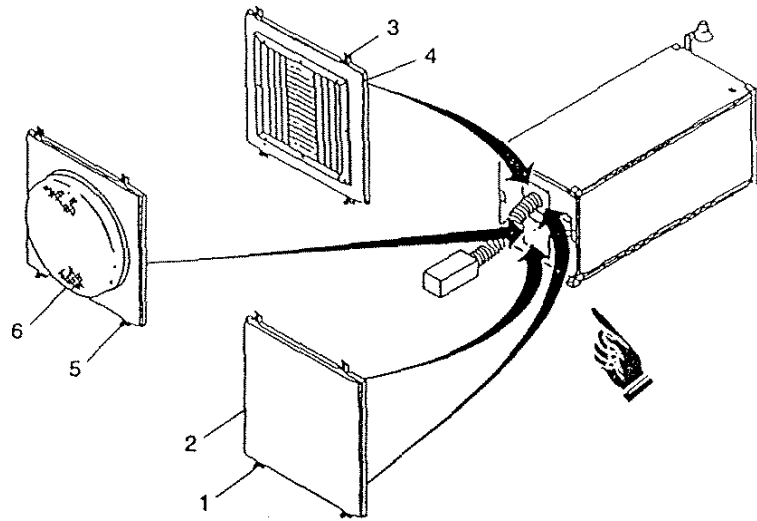

ECU Return Panel

Inside shelter, loosen four captive screws (5) and remove ECU return panel (6).

INSTALLATION

NOTE

ECU intake panel (4) and ECU return panel (6), or closeout panels (2) are stowed in roof panel when not in use.

ECU Return Panel

Position ECU return panel (6) in frame opening and secure by tightening four captive screws (5).

ECU Intake Panel

Position ECU intake panel (4) in frame opening and secure by tightening four captive screws (3).

Closeout Panels

1. Position closeout panel (2) in frame opening and secure by tightening four captive screws (1).
2. Connect ECU ducts and turn on ECU, (Refer to applicable ECU manual.)

This task covers

3-6. CONTAINER LIFT JACK ASSEMBLY REPLACEMENT

- a. Removal
 - b. Cleaning, Inspection
 - c. Installation
-

INITIAL SETUP

Standard tools

General mechanics tool kit

REMOVAL

Personnel -2

1. Place sufficient blocks under ISO fitting or base frame to prevent settling of shelter when jack is removed.

NOTE

Stencil on jack indicates handle rotation to raise or lower jack.

2. Rotate handle (2) to lower jack until upper (3) and lower jack attachments (4) will disengage and jack is not supporting shelter.

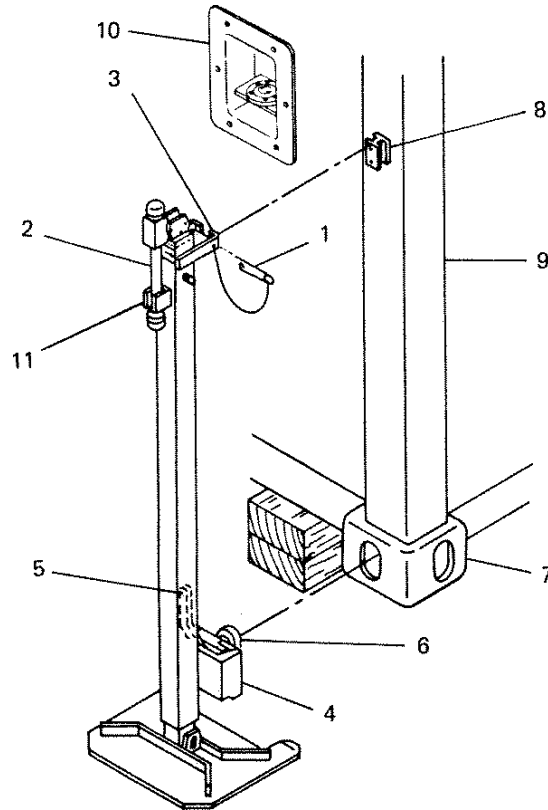

3-6. (cont)

3. Turn locking handle (5) to rotate insert (6) in ISO fitting (7).
4. Remove safety pin (1).
5. Remove jack.

CLEANING, INSPECTION

1. Wipe jack assembly and component surfaces.
2. Inspect mounting surfaces for corrosion and damage.
3. Inspect for missing or damaged components.
4. Inspect for corrosion or paint damage.

INSTALLATION

1. Rotate handle (2) to raise jack until insert (6) will enter lower ISO fitting (7) and upper jack attachment (3) engages jack support bracket (8) on corner post (9).
2. Turn locking handle (5) to rotate insert (6) in ISO fitting (7).
3. Install safety pin (1) through jack support bracket (8) under upper jack attachment (3).
4. Watch level indicator (10), and rotate handle (2) to raise jack until shelter is leveled.
5. Swing handle (2) down and secure in locking clip (11).
6. Remove blocks.

3-7. STORM CONFIGURATION COMPONENTS REPLACEMENT

This task covers:

- a. Removal
- b. Installation

INITIAL SETUP

Standard Tools

General mechanics tool kit

Personnel - 2

References

Operation in High Winds, paragraph 2-20

REMOVAL

1. Release cable by loosening cable clamp (4 places).
2. Remove cable from ISO fitting (4 places).

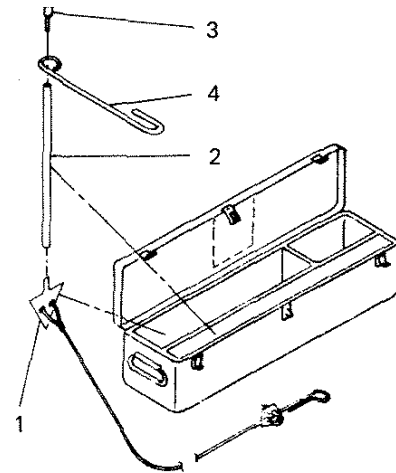
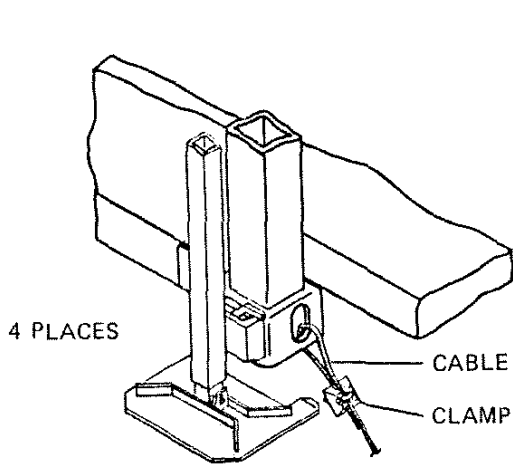

INSTALLATION

Refer to paragraph 2-20 for installation of storm configuration components.

CHAPTER 4

ORGANIZATIONAL MAINTENANCE INSTRUCTIONS

Section I. REPAIR PARTS, SPECIAL TOOLS, TMDE, AND SUPPORT EQUIPMENT

4-1. COMMON TOOLS AND EQUIPMENT.

- a. Appendix B, Section III contains the authorized common tools.
- b. For authorized equipment refer to Modified Table of Organization and Equipment (MTOE) applicable to your unit.

4-2. SPECIAL TOOLS, TMDE, AND SUPPORT EQUIPMENT.

- a. A special tool, hand blind riveter, Appendix B, Item 2 is used for shelter skin repair and general riveting utilizing blind rivets.
- b. Installation tool, Appendix B, Item 3 is used for installation of captive screws.
- c. Portable electric router, Appendix B, Item 14 is used to cut out panels. Use tripod base heat lamp, Appendix B, Item 15 during panel repair.
- d. Fastener header, Appendix B, Item 7 or 8 and box end or adjustable wrench, Appendix B, Item 9 are used to install non-potted inserts.
- e. Multimeter, Appendix B, Item 4, is used to perform all continuity/voltage tests on shelter. Electric tool kit, Appendix B, Item 5 is used to repair wiring.
- f. Use crimping tool, Appendix B, Item 10, to attach wires to receptacle pins on power entry panel.

4-3. REPAIR PARTS. Repair parts covering organizational maintenance for this shelter are listed and illustrated in TM 10-5411-202-24P.

Section II. ORGANIZATIONAL PREVENTIVE MAINTENANCE CHECKS AND SERVICES (PMCS).

PMCS are designed to keep the equipment in good working condition by performing certain tests, inspections, and services. The intervals provide you, the organizational technician, with time schedules that determine when to perform specified tasks.

- a. **Before you operate.** Always keep in mind the CAUTIONS and WARNINGS. Perform your before (B) PMCS.
- b. **While you operate.** Always keep in mind the CAUTIONS and WARNINGS. Perform your during (D) PMCS.
- c. **After you operate.** Be sure to perform your after (A) PMCS.
- d. **If your equipment fails to operate.** Troubleshoot with proper equipment. Report any deficiencies using the proper forms. See DA PAM 738-750.

Table 4-1. Organizational Preventive Maintenance Checks and Services

Item No.	Interval			Item to be Inspected	Procedures Check for and have repaired or adjusted as necessary	For readiness reporting, equipment is Not Ready/ Available if:
	B	D	M			
1	•	•	•	Wiring	Inspect for damage or disconnection	Wiring damaged or disconnected
2	•	•	•	CONTAINER LIFT JACK ASSEMBLIES Container lift jack assemblies	a. Inspect for sinking into ground if shelter not level (check frequently during rainy conditions). b. Inspect for condition and security.	a. Shelter not level b. Jacks damaged or insecure

Section III. TROUBLESHOOTING PROCEDURES

4-4. GENERAL. This Section contains organizational troubleshooting information for locating and correcting common malfunctions which may develop in shelter electrical system.

WARNING

The shelter contains voltages that are dangerous if contacted. Take appropriate precautions when troubleshooting. Before performing continuity checks or replacing electrical components, make sure that electrical power is disconnected from circuit involved.

4-5. TROUBLESHOOTING. Each malfunction for an individual component or unit is listed in paragraph 4-6. The malfunction is followed by a list of tests or inspections which help to determine probable causes and corrective actions to take. The tests or inspections and corrective actions are to be performed in the order listed in the table. All malfunctions that may occur and all tests or inspections and corrective actions may not be listed. If a malfunction is not listed or is not corrected by corrective action, notify your supervisor. Unless otherwise noted, when troubleshooting operation of shelter electrical system, all switches and circuit breakers shall be placed in operating positions with power connected. The electrical system schematic diagram (4-39 or 4-41) and wire list (4-40 or 4-42) are located at the end of Chapter 4, Sec IV.

 4-6. ORGANIZATIONAL MAINTENANCE TROUBLESHOOTING

MALFUNCTION

TEST OR INSPECTION

CORRECTIVE ACTION

 1. NO POWER DISTRIBUTION TO SHELTER.

Step 1. Check that outside power is properly connected to service entrance on power entry panel, check general condition of cable and connectors. Test operation of power entry panel.

- a. Replace defective wiring (paragraph 4-8).
- b. Replace defective connectors (paragraph 4-8).

Step 2. Test operation of main circuit breaker and wiring (paragraph 4-7).

- a. Replace defective wiring (paragraph 4-7).
- b. Replace defective circuit breaker (paragraph 4-7).

2. INCANDESCENT LIGHT FAILS TO COME ON.

Step 1. Check visually for burned out bulb.

Replace bulb (paragraph 4-10).

Step 2. Test operation of incandescent light switch (S3), blackout override switch (S1) and wiring (paragraph 4-10).

- a. Replace defective wiring (paragraph 4-10).
- b. Replace defective switch (paragraph 4-10).

Step 3. Check and reset circuit breaker CB6.

Replace defective circuit breaker (paragraph 4-7).

3. ALL FLUORESCENT LIGHTS FAIL TO COME ON.

Step 1. Check and reset circuit breaker CB6.

Replace defective circuit breaker (paragraph 4-7).

4-6. (cont)

MALFUNCTION

TEST OR INSPECTION

CORRECTIVE ACTION

Step 2. Test operation of fluorescent light switch (54), blackout override switch (SI), and wiring (paragraph 4-7).

a. Replace defective wiring (paragraph 4-7).

b. Replace defective switch (paragraph 4-7).

4. ONE OR MORE FLUORESCENT LIGHTS FAIL TO COME ON.

Step 1. Check visually for burned out fluorescent lamps.

Replace lamp, (paragraph 4-11).

Step 2. Test operation of fluorescent light fixture and wiring (paragraph 4-11).

a. Replace defective wiring (paragraph 4-11).

b. Replace defective light fixture (paragraph 4-11).

WARNING

In the event of lamp breakage, care must be taken in removal of broken glass fragments and white phosphorous dust that may be dispersed within fixture. Inhalation of phosphorous dust could cause dangerous injury.

5. NO POWER AT ONE OR MORE UTILITY OUTLETS.

Step 1. Check and reset associated circuit breaker CB3 or CB5.

Replace defective circuit breaker (paragraph 4-7).

Step 2. Test operation of utility outlet and wiring (paragraph 4-12).

a. Replace defective wiring (paragraph 4-12).

b. Replace defective outlet (paragraph 4-12).

4-6. (cont)

MALFUNCTION	TEST OR INSPECTION	CORRECTIVE ACTION
6. NO POWER AT ECU SUPPLY CONNECTOR.		
Step 1.	Check and reset circuit breaker CB1.	Replace defective circuit breaker (paragraph 4-7).
Step 2.	Test operation of connector and wiring (paragraphs 4-8, 4-15, and 4-16A).	<ul style="list-style-type: none"> a. Replace defective wiring (paragraphs 4-8, 4-15, and 4-16A). b. Replace defective connector (paragraphs 4-8 and 4-15).
7. NO POWER AT ONE OR BOTH EXTERIOR UTILITY OUTLETS.		
Step 1.	Check and reset circuit breaker CB8.	Replace defective circuit breaker (paragraph 4-7).
Step 2.	Test operation of associated exterior utility outlet and wiring (paragraph 4-12).	<ul style="list-style-type: none"> a. Replace defective wiring (paragraph 4-12). b. Replace defective outlet (paragraph 4-12).

Section IV. ORGANIZATIONAL MAINTENANCE PROCEDURES

This section contains the following maintenance procedures for the shelter.

LIST OF FUNCTIONS

Function No.	Function	Function Ref. (paragraph)
1	Circuit Breaker Panel Assembly Testing, Replacement and Repair	4-7
2	Replacement of Obsolete NQOB Circuit Breaker Panel with New NQOD Circuit Breaker Panel	4-7.1
3	Power Entry Panel Assembling Testing, Replacement and Repair	4-8
4	Area Light Assembly Testing and Repair	4-9
5	Incandescent Light Assembly Testing, Replacement and Repair	4-10
6	Ceiling Light Testing, Replacement and Repair	4-11
7	Receptacle Outlets Testing, Replacement, and Repair	4-12
8	Wall Switches Replacement	4-13
9	Blackout Switch Replacement, Repair, and Adjustment	4-14
10	Power Panel ECU Assembly Testing, Replacement and Repair	4-15
11	Wiring Testing, Replacement and Repair	4-16
11A	Raceway Assembly Testing, Replacement, and Repair	4-16.1
12	Personnel Door Replacement, Repair and Alignment	4-17
13	Container Lift Jack Assemblies Service and Repair	4-18
14	Personnel Endwall Panel Replacement and Repair	4-19
15	Front Endwall Panel Replacement and Repair	4-20
16	Sidewall Panel Replacement and Repair	4-21
17	Roof Panel Assembly Repair	4-22
18	Floor Panel Repair	4-23
19	Equipment Container Replacement and Repair	4-24
20	Drying Water-Soaked Areas In Panels	4-25
21	Blind Rivet Removal and Installation	4-26
22	Repair of Small Dent or Depression	4-27
23	Repair of Depression or Small Puncture	4-28
24	Repair of Puncture With Minimal Damage to Core	4-29
25	Repair of Puncture With Core Fracture	4-30
26	Repair of Damage With Extended Cracks	431
27	Repair of Puncture Through One Skin and Core	4-32
28	Repair of Puncture Through Both Skins and Core	4-33
29	Shelter Body Seals Replacement	4-34
30	Threaded Inserts Replacement	4-35
31	Caulking Repaired Areas	4-36
32	Paint Refinishing	4-37
33	Decal Removal/Replacement	4-38
34	Electrical System Schematic Diagram	4-39
35	Wire List	4-40

4-7. CIRCUIT BREAKER PANEL ASSEMBLY TESTING, REPLACEMENT, AND REPAIR (MODELS NQOB AND NQOD)

This task covers:

- | | |
|-------------------------|-----------------|
| a. Testing | d. Repair |
| b. Removal | e. Installation |
| c. Cleaning, Inspection | |
-

INITIAL SETUP

Standard Tools

General Mechanics Tool Kit

Test Equipment

Multimeter, Appendix B, Item 4
Electrical Tool Kit, Appendix B,
Item 5

Personnel Required

Electrician

TESTING

WARNING

Disconnect electrical power from shelter before testing. Failure to observe this warning may cause death or serious injury to personnel.

1. Tag and disconnect shelter electrical power.
2. Set all circuit breakers and switches to OFF position.

NOTE

This procedure covers the obsolete NQOB circuit breaker panel and the new NQOD circuit breaker panel. These units are distinguishable by the nameplates (9) attached to the panelboards.

4-7. (cont)

3. Open circuit breaker panel door (1) on both models.
4. Loosen four captive screws (2) and move clamp fingers (3) to OPEN position on model NQOB.
5. Lift circuit breaker panel cover (4) from panel board (5) on model NQOB.
6. Remove four screws (6) and washers (7) and lift panel board (5) from circuit breaker box (8) on both models.

NOTE

Once the panelboards are removed, all further procedures are identical for both models.

7. Reconnect site power.
8. Set main circuit breaker to ON position.
9. Set branch circuit breakers to ON position and observe if any breakers pop to OFF position.
10. Disconnect site power.
11. Using multimeter, check for continuity of circuit breakers, light switches, and wiring.
12. If no continuity is present, replace defective circuit breaker, light switch, or panel wiring.

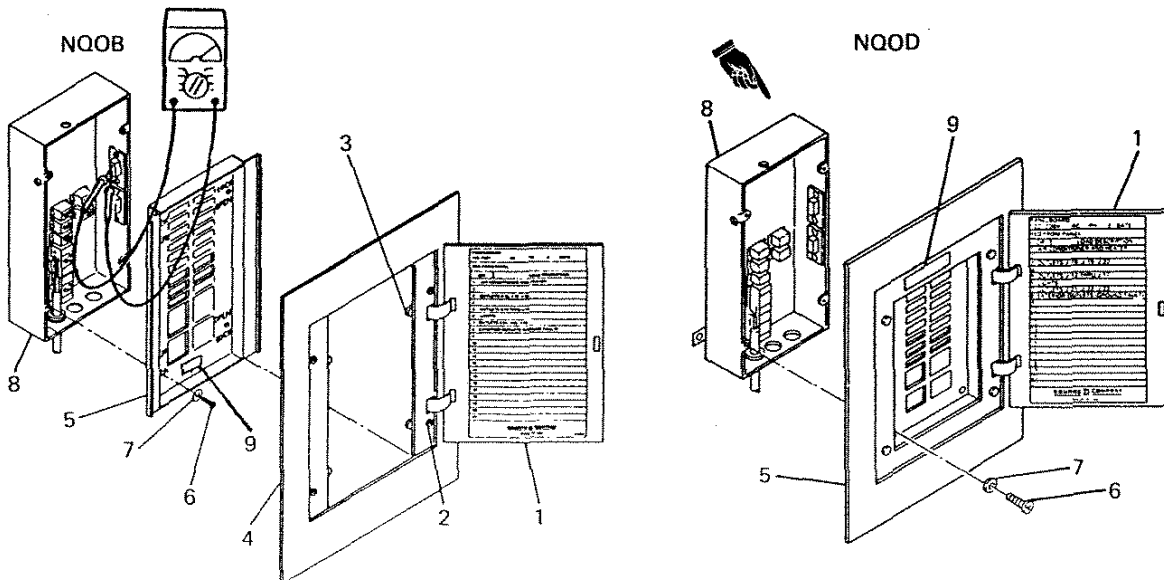

4-7. (cont)

REMOVAL

WARNING

Disconnect electrical power from shelter before removing components. Failure to observe this warning may cause death or serious injury to personnel.

1. Tag and disconnect shelter electrical power.
2. Set all circuit breakers and switches to OFF position.

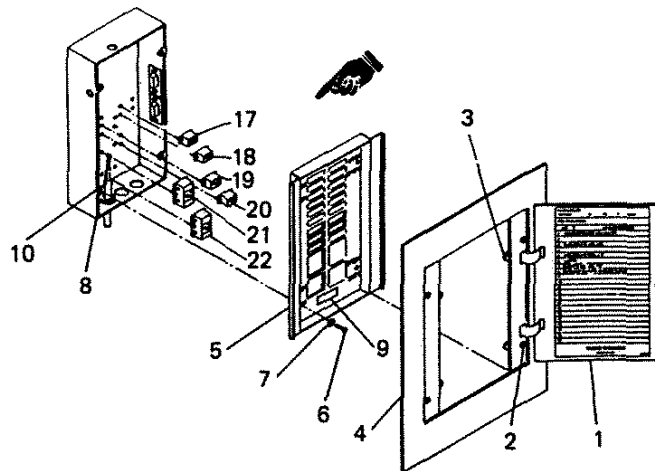

NOTE

This procedure covers the obsolete NQOB circuit breaker panel and the new NQOD circuit breaker panel. These units are distinguishable by the nameplates (9) attached to the panelboards.

3. Open circuit breaker panel door (1) on both models.
4. Loosen four captive screws (2) and move clamp fingers (3) to OPEN position on model NQOB.
5. Lift circuit breaker panel cover (4) from panel board (5) on model NQOB.
6. Remove four screws (6) and washers (7) and lift panel board (5) from circuit breaker box (8) on both models.

4-7. (cont)

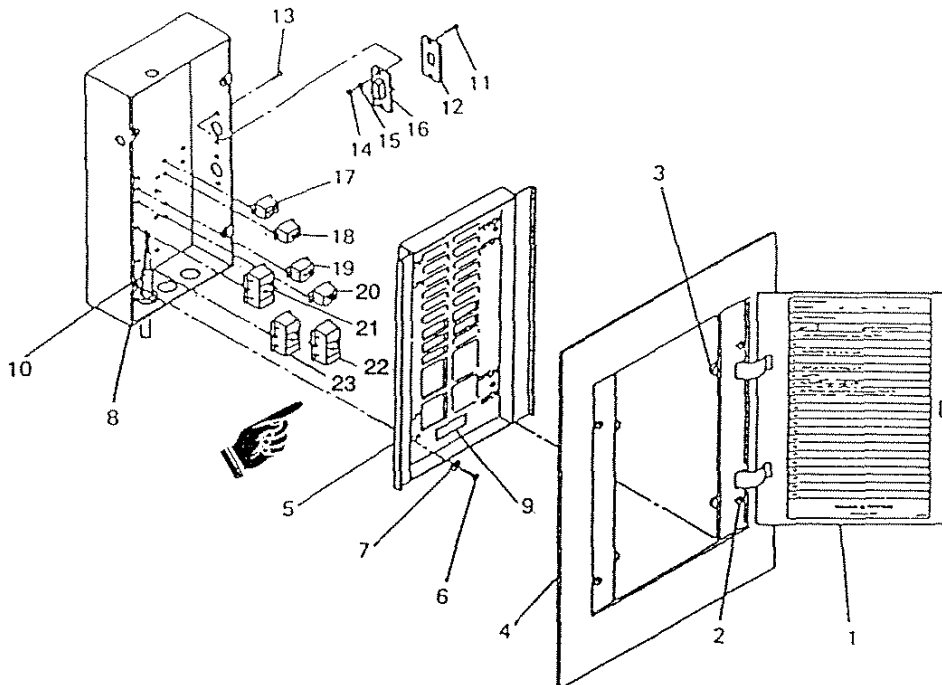

NOTE

Once the panelboards are removed, all further procedures are identical for both models.

Light Switches

7. Tag and disconnect wires (10) from light switches (16).
8. Remove four screws (11) from two switch covers (12).
9. Remove four screws (13), nuts (14), and lockwashers (15), and remove two light switches (16) from circuit breaker box (8).

Circuit Breakers

10. Tag and disconnect wires (10) from circuit breakers (17 through 23).
11. Remove circuit breakers (17 through 23) from circuit breaker box (8).

CLEANING, INSPECTION

1. Clean circuit breaker panel and component surfaces.

4-7. (cont)

NOTE

Do not use water to clean circuit breaker panel assembly.

2. Inspect mounting surfaces for corrosion and damage.
3. Inspect for damaged circuit breakers or light switches.
4. Inspect panel wiring for cracks, tears, burns, or other damage.

REPAIR

1. Replace damaged circuit breakers or light switches.
2. Repair or replace damaged wiring.

INSTALLATION

Circuit Breakers

1. Install circuit breakers (17 through 22) in circuit breaker box (8).
2. Connect wires (10) to circuit breakers (17 through 22).

Light Switches

3. Position two light switches (16) in circuit breaker box (8) and secure with four screws (13), nuts (14), and lockwashers (15).
4. Position two switch covers (12) over light switches (16) and secure with four screws (11).
5. Connect wires (10) to light switches (16).
6. Attach panelboard (5) to circuit breaker box (8) with screws (6) and washers (7).
7. Place panel cover (4) on model NQOB panelboard (5), move clamp fingers (3) to LOCK position and tighten captive screws (2).
8. Close circuit breaker panel door (1).

4-7.1 REPLACEMENT OF OBSOLETE NQOB CIRCUIT BREAKER PANEL WITH NEW NQOD CIRCUIT BREAKER PANEL.

This task covers:

- a. Removal
- b. Disassembly
- c. Installation
- d. Assembly

INITIAL SETUP

Standard Tools

General Mechanics Tool Kit

Test Equipment

Blind Nut Assemblies (4),
Appendix E, Item 26
Conduit (P/N 5-4-5061-2)
New Circuit Breaker Panel
NQOD (P/N 5-4-3199)

Personnel Required

Electrician

WARNING

Disconnect electrical power from shelter before disassembling circuit breaker panel. Failure to observe this warning may cause death or serious injury to personnel.

NOTE

All parts removed from the obsolete NQOB circuit breaker panel are reusable in the installation of the new NQOD circuit breaker panel with the following exceptions: circuit breaker box, panelboard, panel cover, and conduit entering the top of circuit breaker box. The new NQOD circuit breaker panel (P/N 5-4-3199) consists of breaker box and panel cover. The box is prepunched to accept light switches, wiring entry, and mounts for circuit breakers.

4-7.1 (cont)

REMOVAL

1. Tag and disconnect shelter electrical power.
2. Refer to paragraph 4-7 for removal of panel cover, panelboard, light switches, circuit breakers.

DISASSEMBLY

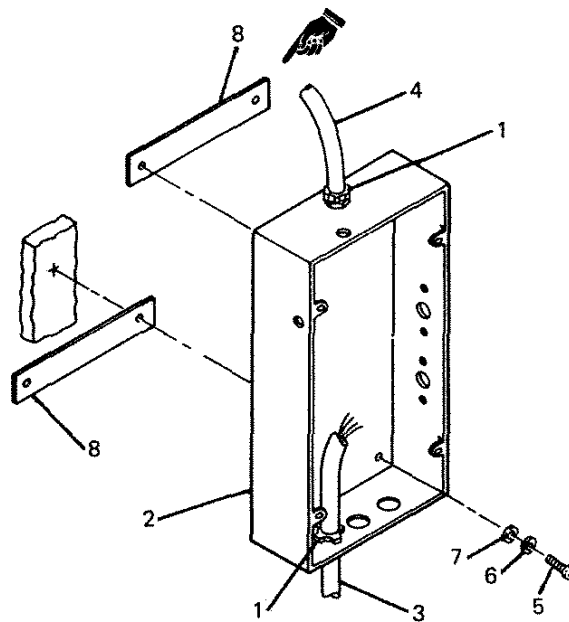

1. Remove insulated connectors (1) from inside circuit breaker box (2), pull conduit and wires (3) and (4) away from box. Remove other end of conduit (4) from box on left side of roof beam. Slide conduit over wires and discard. A new piece of conduit which is 2-inches longer will be used during installation of new box.
2. Remove four screws (5), lockwashers (6) and flat washers (7) and remove circuit breaker box (2) and spacers (8) from the wall.

4-7.1 (cont)

INSTALLATION

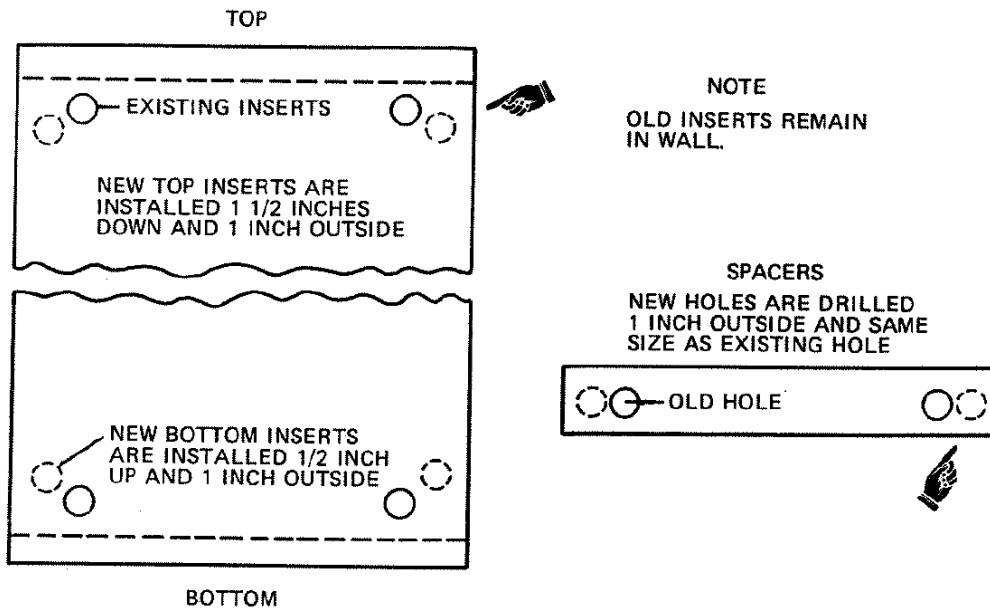

1. Install new inserts (refer to paragraph 4-35).
2. Drill new holes in spacers.

4-7.1 (cont)

ASSEMBLY

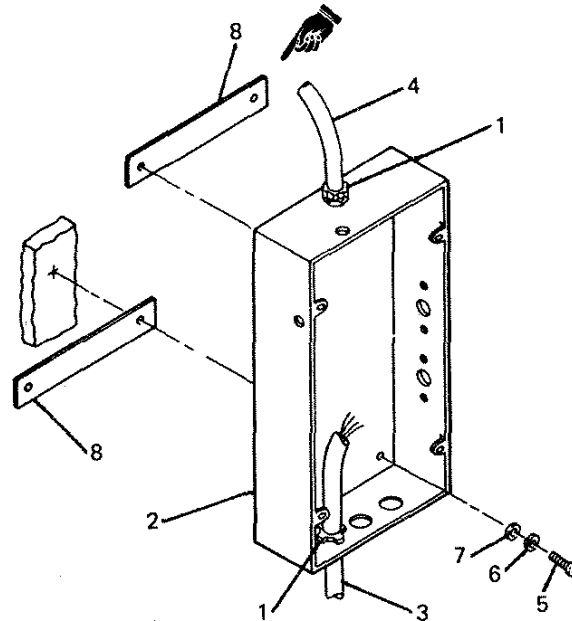

1. Align spacers (8) and circuit breaker box (2) with new inserts and secure with screws (5), lockwashers (6), and washers (7).
2. Slide new conduit (P/N 5-4-5061-2) over wires and secure in box on left side of roof beam.
3. Insert conduit (3) and (4) into circuit breaker box (2) and secure with insulated connectors (1).
4. Refer to paragraph 4-7 for installation of circuit breakers, light switches, wiring, and panelboard with cover.
5. Connect shelter electrical power and remove tags.
6. Refer to paragraph 4-7 for testing.

4-8. POWER ENTRY PANEL ASSEMBLY

This task covers:

- | | |
|-------------------------|-----------------|
| a. Testing | e. Repair |
| b. Removal | f. Assembly |
| c. Disassembly | g. Installation |
| d. Cleaning, Inspection | |
-

INITIAL SETUP

Standard Tools

General mechanics tool kit
Electrical tool kit

Test Equipment

Multimeter, Appendix B, Item 4

Personnel Required

Electrician

TESTING

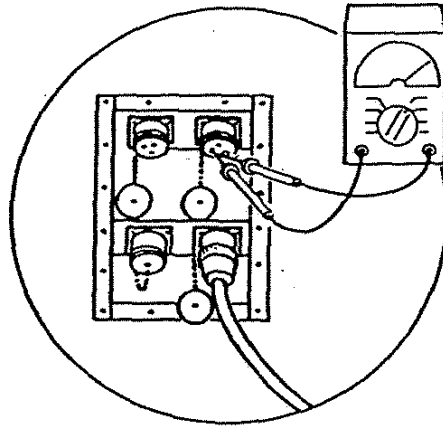

1. Connect site power.
2. Unscrew connector covers from connectors.
3. Set all circuit breakers in ON position.
4. Using multimeter, check for proper voltage at each receptacle pin.
5. If improper voltage is present, replace defective receptacles, terminals/connectors, or panel wiring.

WARNING

Disconnect all power sources from power entry panel assembly before removing.

4-8. (cont)

REMOVAL

1. Inside shelter, remove screws (1), lockwashers (2), and washers (3), and carefully lift cover assembly (4) away from front endwall panel as far as it will go.

NOTE

Tag all wires for reconnection.

2. Disconnect wires at receptacles and terminals/connectors from back of power entry panel assembly (5).
3. Outside shelter, drill out rivets (6) and remove power entry panel assembly (5) from front endwall panel. (Refer to 4-26.)

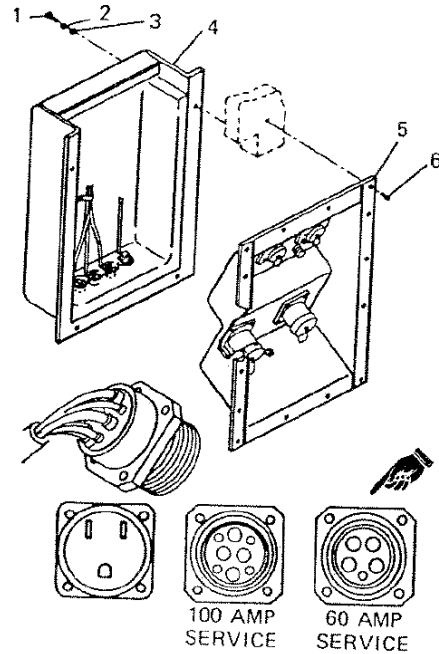

DISASSEMBLY

1. Remove screws (1), lockwashers (2), receptacle covers (3), and nuts (4).
2. Remove receptacles (5 and 6) and gaskets (7) from panel (8).

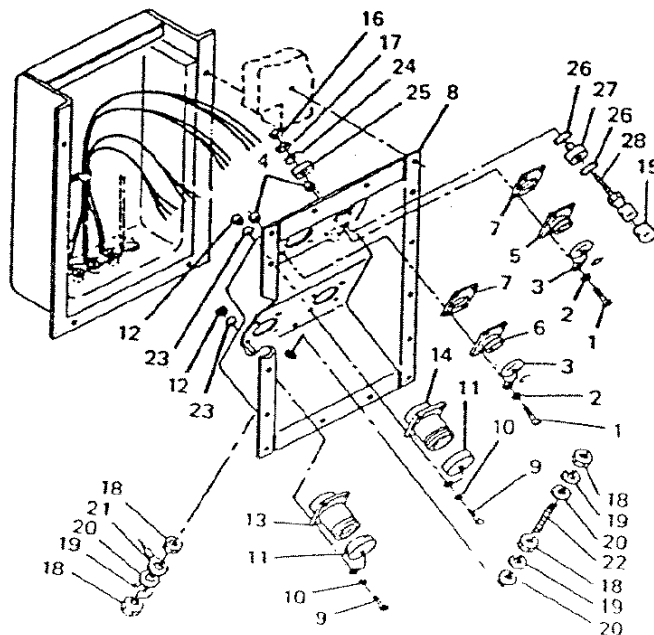

4-8. (cont)

3. Remove screws (9), lockwashers (10), receptacle covers (11), nuts (12), and washers (23).
4. Remove receptacles (13 and 14) from panel (8).
5. Remove rubber cap (15), nut (16), lockwasher (17), brass washer (24), nylon washer (25), two O-rings (26), nylon washer (27), and binding post body (28) from panel (8).
6. Remove four nuts (18), three lockwashers (19), three washers (20), terminal lug (21), and threaded stud (22) from panel (8).

CLEANING, INSPECTION

1. Wipe power entry panel and component surfaces.
2. Inspect mounting surfaces for corrosion and damage.
3. Inspect for damaged receptacles, binding posts, terminals, or threaded stud.

REPAIR

1. Replace damaged receptacles, binding posts, terminals, or threaded stud.
2. Repair corrosion or paint damage. (Refer to 4-37.)

ASSEMBLY

1. Install threaded stud (22), terminal lug (21), three washers (20), three lockwashers (19), and four nuts (18) in panel (8).
2. Install binding post body (28), nylon washer (27), two O-rings (26), nylon washer (25), brass washer (24), lockwasher (17), nut (16), and rubber cap (15) in panel (8).
3. Using crimping tool, attach wires to receptacle pins. (Refer to 4-40.)
4. Install receptacles (13 and 14) in panel (8) and secure with screws (9), lockwashers (10), receptacle covers (11), washers (23), and nuts (12).
5. Install receptacles (5 and 6) and gaskets (7) in panel (8) and secure with screws (1), lockwashers (2), receptacle covers (3), and nuts (4).

4-8. (cont)

INSTALLATION

1. Position power entry panel assembly (5) against outside of front endwall panel and secure with rivets (6). (Refer to 4-26.)
2. Connect wires to receptacles and terminals/connectors at rear of power entry panel assembly (5). (Refer to 4-40.)
3. Position cover assembly against inside of front endwall panel and secure with screws (1), lockwashers (2), and washers (3).
4. Reconnect electrical power to service entrance receptacle.

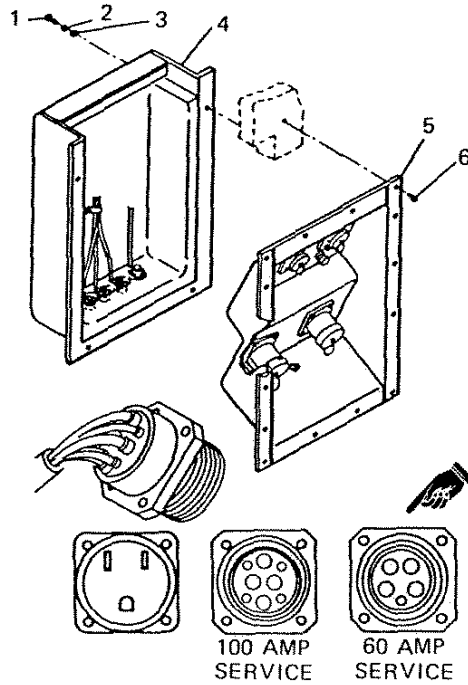

4-9. AREA LIGHT ASSEMBLY

This task covers:

- | | |
|-------------------------|-------------|
| a. Testing | d. Repair |
| b. Disassembly | e. Assembly |
| c. Cleaning, Inspection | |
-

INITIAL SETUP

Special Tools

Hand blind riveter, Appendix B, Item 2

Test Equipment

Multimeter, Appendix B, Item 4

Standard Tools

General mechanics tool kit
Electrical tool kit

Personnel

Electrician
Sheet metal worker

Equipment Condition

Area light assembly removed
(3-4)
All circuit breakers and
switches in OFF position

WARNING

The light assembly contains voltage that is dangerous if contacted.

TESTING

1. Remove flood light (1) from lamp holder (2).
2. Unscrew two captive screws (3) and remove conduit outlet cover (4) and gasket (5) from exterior light post (6).
3. Using multimeter, check for continuity at lamp socket and wiring.
4. If no continuity is present, replace defective lamp or wiring.

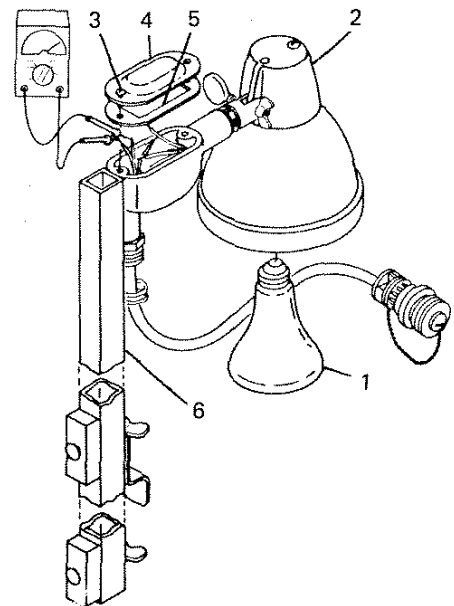

DISASSEMBLY

1. Unscrew flood light (1) from lamp holder (2).
2. Remove wing nut (3) and thumb screw (4) from lamp holder (2).
3. Unscrew two captive screws (5) and remove conduit outlet cover (6) and gasket (7).
4. Remove three wire nuts (8) and separate three wires in lamp holder (2) from three wires of electrical cord (9) in exterior light post (10).

4-9. (cont)

5. Separate lamp holder (2) from exterior light post (10).
6. Remove locknut (21).
7. Rotate screw on clamp (12) one-quarter turn, open clamp (12), and remove electrical cord (9).
8. Drill out two rivets (11) and remove clamp (12) from exterior light post (10). (Refer to 4-26.)
9. Remove electrical cord (9) from exterior light post (10).

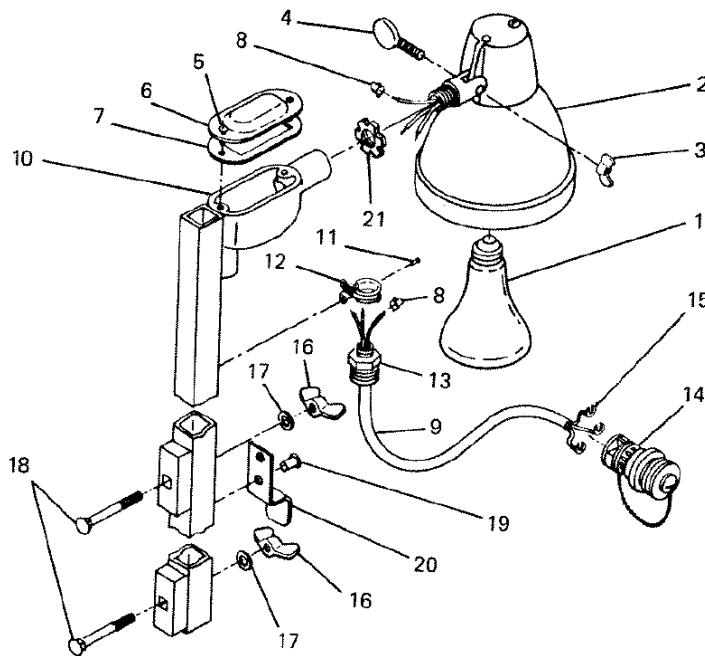

10. Separate liquid tight connector (13) and connector (14) from electrical cord (9).
11. Remove three terminal lugs (15) from three wires in electrical cord (9).
12. Remove two wing nuts (16), washers (17), and bolts (18) from exterior light post (10).
13. Drill out four rivets (19) and remove two cord stowage brackets (20) from exterior light post (10). (Refer to 4-26.)

CLEANING, INSPECTION

1. Wipe area light assembly and component surfaces.
2. Inspect mounting surfaces for corrosion and damage.

4-9. (cont)

3. Inspect for and replace if necessary:
 - a. Missing or damaged components,
 - b. Corrosion or paint damage.

REPAIR

Repair corrosion or paint damage. (Refer to 4-37.)

ASSEMBLY

1. Position two cord storage brackets (20) on exterior light post (10) and install four rivets (19). (Refer to 4-26.)
2. Install two bolts (18), washers (17), and wing nuts (16) in exterior light post (10).
3. Assemble three terminal lugs (15) to three wires on one end of electrical cord (9) and attach connector (14) at that end.
4. Place electrical cord (9) through clamp (12) and attach clamp to exterior light post with two rivets (11) and close clamp. (Refer to 4-26.)
5. Assemble liquid tight connector (13) to opposite end of electrical cord (9) and install assembly in exterior light post (10). Make sure three wires extend through opening at top of exterior light post (10).
6. Assemble locknut (21) on lamp holder (2).
7. Assemble lamp holder (2) to exterior light post (10) and install thumb screw (4) and wing nut (3). Make sure three wires extend through opening at top of exterior light post (10).

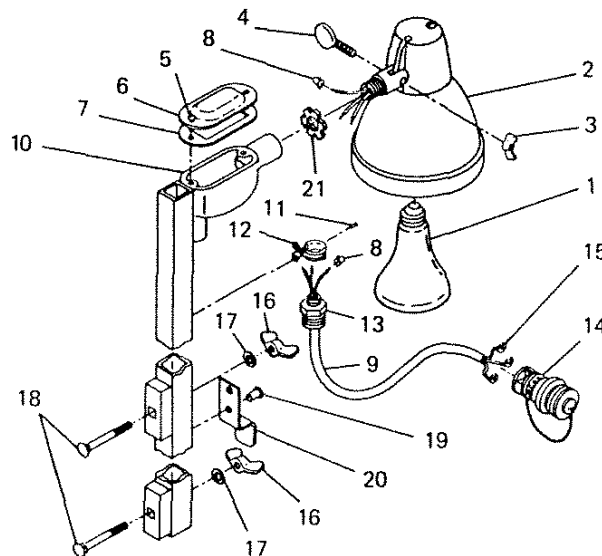

4-9 (cont)

8. Connect three wires from electrical cord (9) to three wires from lamp holder (2) as follows:

<u>From</u> <u>Electrical Cord</u>	<u>To</u> <u>Lamp Holder</u>
Black Wire	Black Wire
White Wire	White Wire
Green Wire	Bare Wire

9. Secure these wires with three wire nuts (8).
10. Make sure connected wires are positioned in opening at top of exterior light post (10) and assemble gasket (7) and outlet cover (6) to top of exterior light post (10) with two captive screws (5).
11. Install flood light (1) in lamp holder (2).

4-10. INCANDESCENT LIGHT ASSEMBLY

This task covers.

- | | |
|---|--|
| <ol style="list-style-type: none"> a. Testing b. Removal c. Cleaning, Inspection | <ol style="list-style-type: none"> d. Repair e. Installation |
|---|--|

INITIAL SETUP

Standard Tools

General mechanics tool kit
Electrical tool kit

Personnel

Electrician

Test Equipment

Multimeter, Appendix B, Item 4

WARNING

This fixture contains voltage that is dangerous if contacted. Before replacing incandescent light assembly, set all circuit breakers and switches to OFF position.

TESTING

1. Set all circuit breakers and switches to OFF position.
2. Remove two screws (1) and cover (2).
3. Unscrew bulb (3) from light fixture (4).

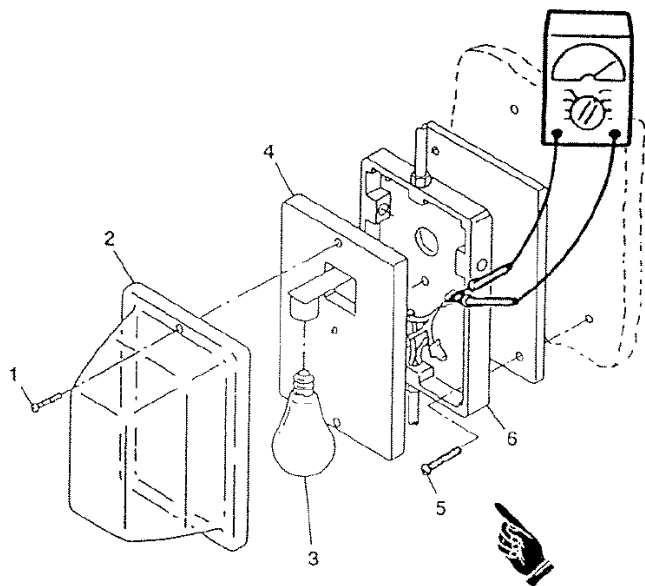

4-10. (cont)

4. Remove screw (5) and separate light fixture (4) from light fixture adapter (6) as far as it will go.
5. Using multimeter, check for continuity at bulb socket and wiring.
6. If no continuity is present, replace defective light fixture or wiring.

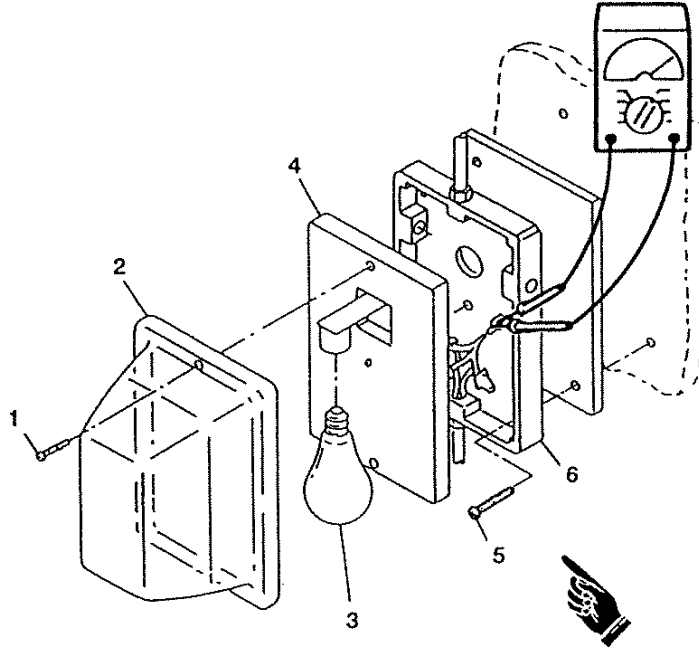

REMOVAL

1. Remove two screws (1) and switch cover (2).
2. Remove two screws (3) and pull switch (4) from outlet box (24) as far as it will go

NOTE

Tag wires for reconnection

3. Disconnect wires at rear of switch (4).
4. Remove two screws (5) and light fixture cover (6). Remove bulb (23).
5. Remove screw (7) and separate light fixture (8) from light fixture adapter (9) as far as it will go.

4-10. (cont)

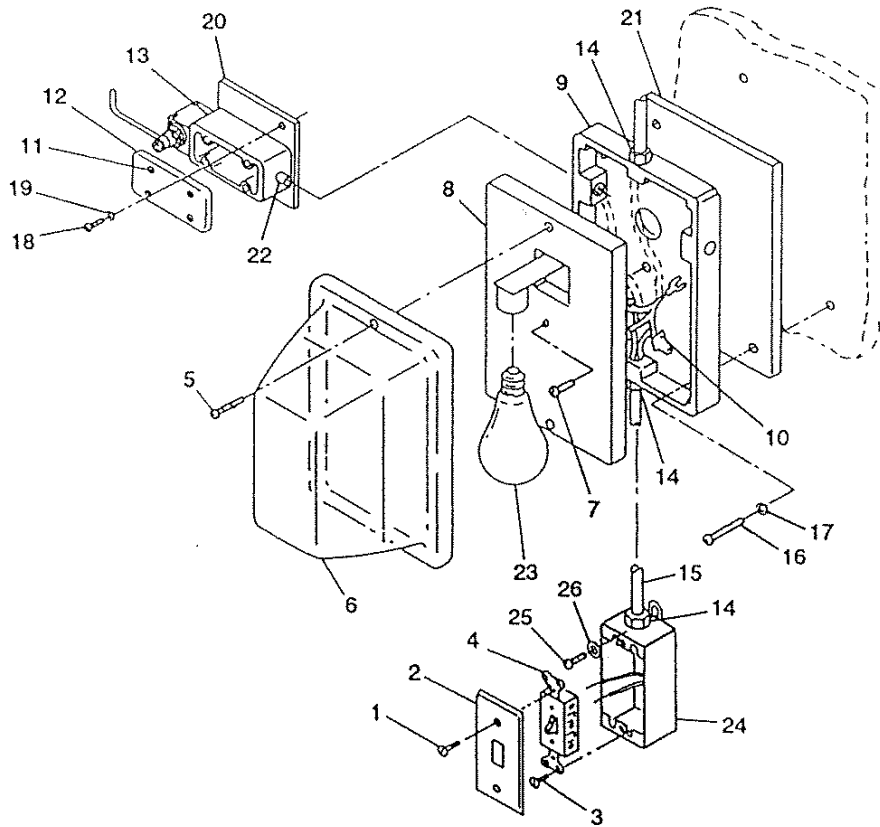

NOTE

Tag wires for reconnection.

6. Remove wire nuts (10) and disconnect wires from rear of light fixture (8).
7. Loosen four captive screws (11) and remove limit switch cover (12).

NOTE

Tag wires for reconnection

8. Disconnect three sets of wires plus one ground wire inside limit switch (13).
9. Pull wires up through lower conduit (15) and into light fixture adapter (9).

4-10. (cont)

10. Remove two screws (25) and lockwashers (26), and remove outlet box (24) from endwall.
11. Loosen connectors (14) between conduit (15) and outlet box (24), and conduit (15), and light fixture adapter (9), and remove conduit (15).
12. Remove two screws (18) and lockwashers (19) from limit switch mounting plate (20).
13. Separate limit switch (13) from light fixture adapter (9) by unscrewing nipple (22).
14. Remove two screws (16) and lockwashers (17) from light fixture adapter (9) and incandescent light spacer (21).
15. Separate light fixture adapter (9) from conduit above by unscrewing nipple (14).

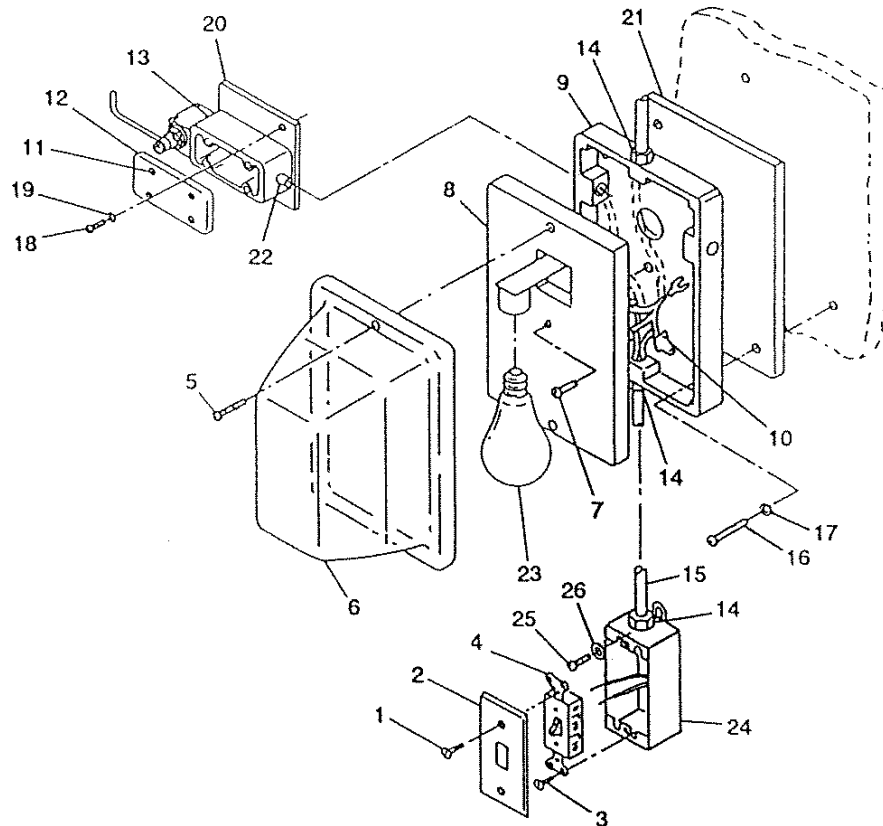

4-10. (cont)

CLEANING, INSPECTION

1. Wipe incandescent light assembly and component surfaces.
2. Inspect mounting surfaces for corrosion and damage.
3. Inspect for and replace if necessary:
 - a. Missing or damaged components.
 - b. Corrosion or paint damage.

REPAIR

Corrosion or paint damage. (Refer to pars 4-37).

INSTALLATION

1. Assemble light fixture adapter (9) to conduit above with nipple (14).
2. Assemble light fixture adapter (9) and incandescent light spacer (21) to endwall with two screws (16) and lockwashers (17).
3. Assemble limit switch (13) to light fixture adapter (9) with nipple (22).
4. Assemble light switch (13) with limit switch mounting plate (20), to endwall with two screws (18) and lockwashers (19).
5. Pass wires through nipple (22) into light fixture adapter (9) and connect wires. (Refer to para 4-40.)
6. Pass wires from outlet box (24) through nipple (14), through conduit (15), and through nipple (14), to light fixture adapter (9) and connect wires. (Refer to para 4-40.)
7. Connect wires in outlet box (24) to switch (4) and assemble switch to outlet box with two screws (3).
8. Assemble light switch cover (12) to limit switch (13) by tightening four captive screws (11).

4-10. (cont)

9. Assemble switch cover (2) to outlet box (24) with two screws (1).
10. Assemble light fixture (8) to light fixture adapter (9) with screw (7). Insert bulb (23).
11. Assemble light fixture cover (6) to light fixture (8) with two screws (5).

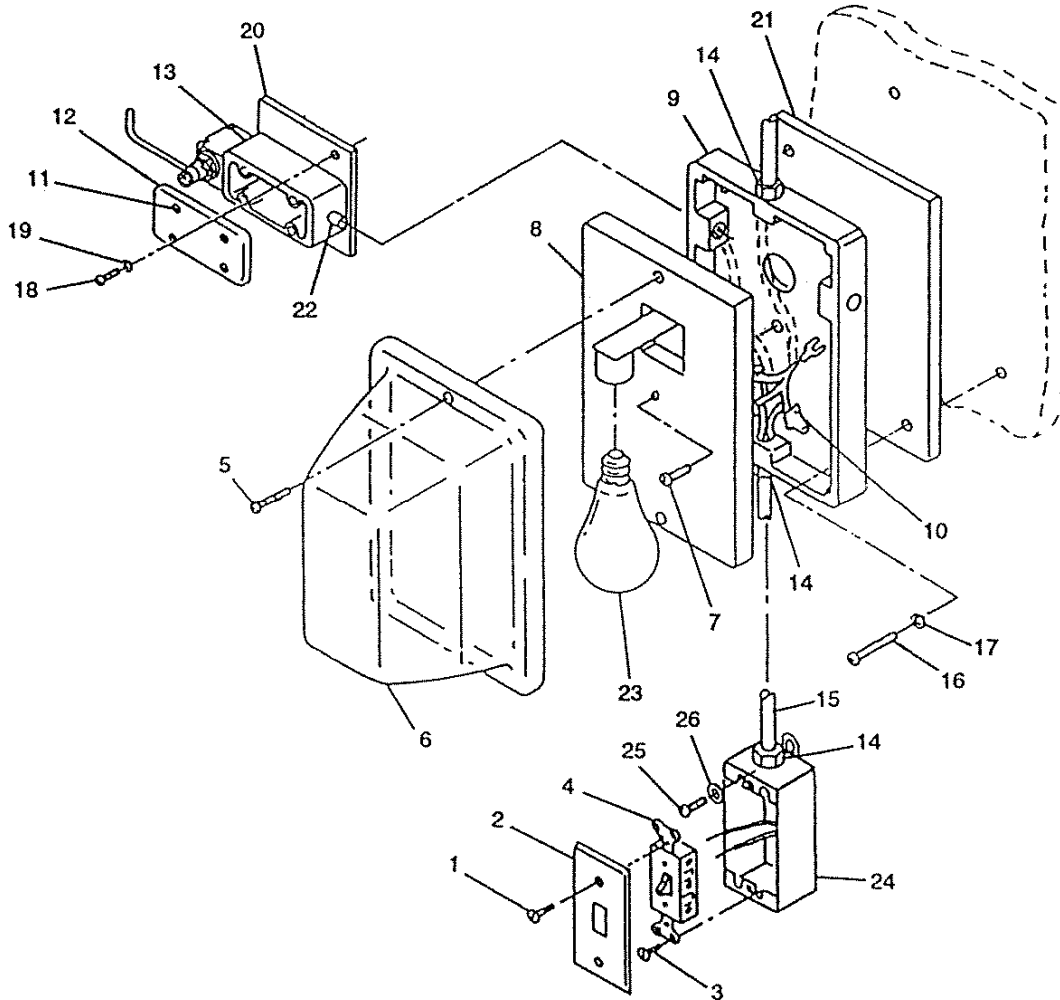

4-11. CEILING LIGHT

This task covers:

- | | |
|-------------------------|-----------------|
| a. Testing | e. Repair |
| b. Removal | f. Assembly |
| c. Disassembly | g. Installation |
| d. Cleaning, Inspection | |
-

INITIAL SETUP

Special Tools

Hand blind riveter, Appendix B, Item 2

Test Equipment

Multimeter, Appendix B, Item 4

Standard Tools

General mechanics tool kit

Electrical tool kit

Personnel

Electrician

Equipment Condition

All circuit breakers and switches in OFF position

TESTING

1. Remove three screws (1) and cover (2).
2. Using multimeter, check for continuity at fluorescent lamps, ballast and electrical cord.

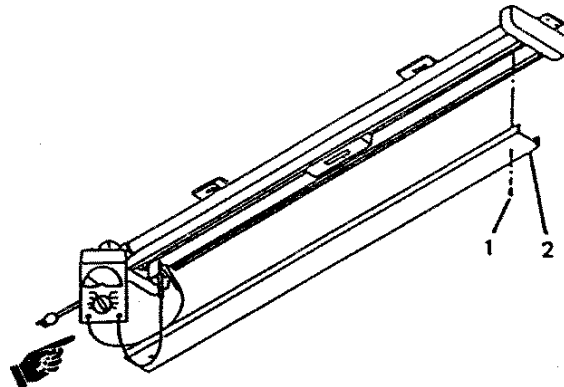

WARNING

This fixture contains voltage that is dangerous if contacted. Before replacing fixed roof area ceiling light, set all circuit breakers and switches to OFF position.

3. If no continuity is present, replace defective fluorescent lamp, ballast, or wiring.

4-10. (cont)

REMOVAL

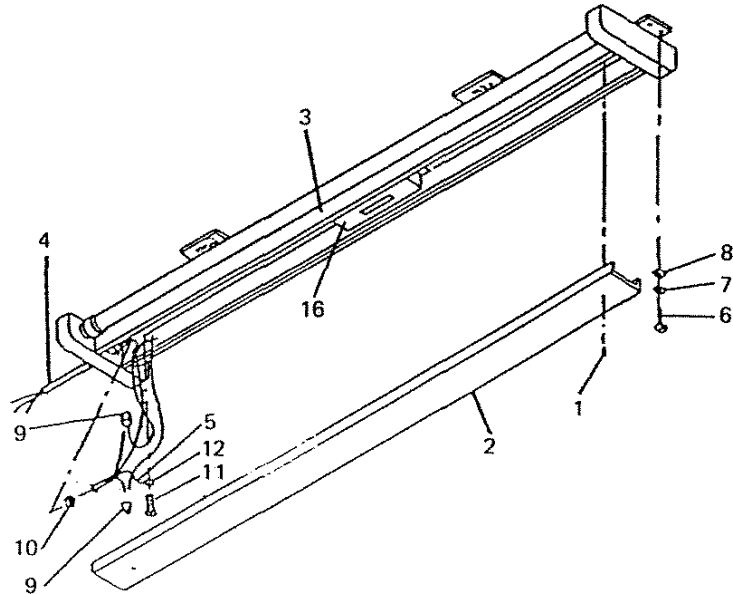

1. Remove three screws (1) and cover (2) from ceiling light (3).

NOTE

Tag wires for reconnection.

2. Remove wire nuts (9) and separate wires connected to ballast (16).
3. Remove installation screw (11) attaching terminal lug (12) on third wire (5) to conduit (4).
4. Remove locknut (10) and remove conduit (4) and wires from ceiling light (3).
5. Remove four screws (6), lockwashers (7), and washers (8), and remove ceiling light (3) from roof assembly.

4-11. (cont)

DISASSEMBLY

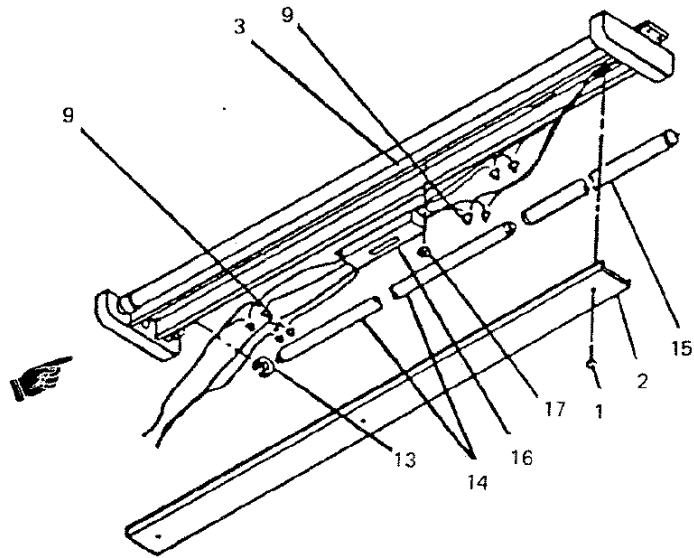

WARNING

In the event of lamp breakage, care must be taken in the removal of broken glass fragments and white phosphorus dust that may be dispersed within the fixture. Inhalation of phosphorus dust could cause serious injury.

1. Remove screws (1) and cover (2) from light frame (3).

CAUTION

When removing end caps, hold safety tube level to prevent fluorescent tube from accidentally sliding out and dropping.

2. Remove split retaining rings (13) from one end of fluorescent lamps (14).

4-11. (cont)

3. Remove two fluorescent lamps (14) with light shields (15) by rotating and sliding out of light frame (3). Remove light shields (15) from fluorescent lamps (14).
4. Tag and disconnect all wires connecting light frame (3) and ballast (16) by removing wire nuts (9).
5. Remove nuts (17) and remove ballast (16) from light frame (3).

CLEANING, INSPECTION

1. Wipe ceiling light and component surfaces.
2. Inspect mounting surfaces for corrosion and damage.
3. Inspect for and replace if necessary:
 - a. Missing or damaged components.
 - b. Corrosion or paint damage.

REPAIR

Repair corrosion or paint damage. (Refer to paragraph 4-37.)

4-11. (cont)

ASSEMBLY

1. Position ballast (16) in light frame (3) and secure with nuts (17).
2. Connect all wires connecting light frame (3) and ballast (16) and remove tags.
3. Secure all wires with wire nuts (9).
4. Assemble light shields (15) on fluorescent lamps (14) and install in light frame (3) by sliding in and rotating.
5. Install split retaining rings (13).
6. Attach cover (2) to light frame (3) with screws (1).

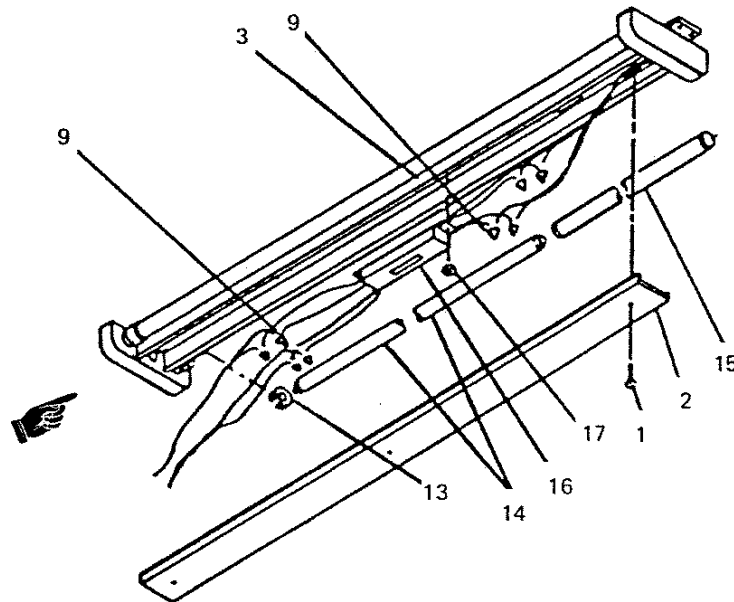

4-11. (cont)

INSTALLATION

1. Position ceiling light (3) against roof assembly and install washers (8), lockwashers (7), and screws (6).
2. Pull wires from conduit (4) into light (3) and attach conduit with locknut (10).
3. Connect wires from conduit (4) to ballast (6) with wire nuts (9), and remove tags.
4. Attach terminal lug (12) to ceiling light (3) with installation screw (11).
5. Attach cover (2) to ceiling light (3) with screws (1).

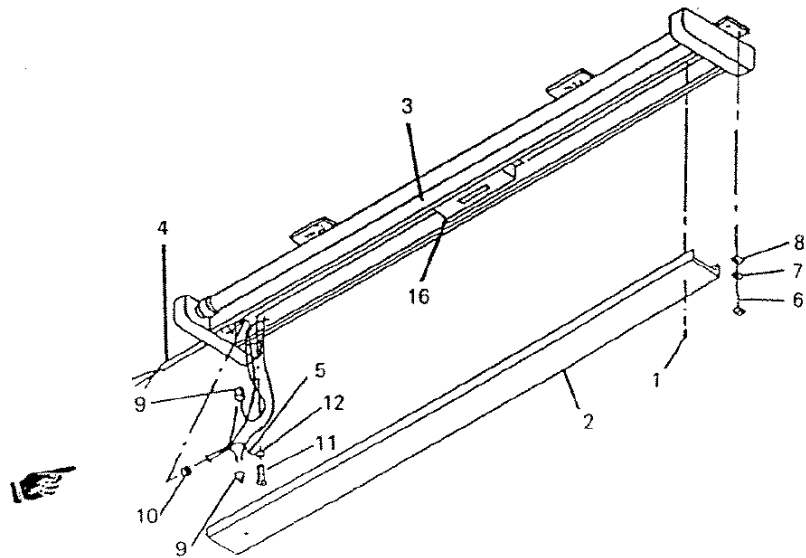

4-12. RECEPTACLE OUTLETS

This task covers:

- | | |
|-------------------------|-----------------|
| a. Testing | e. Repair |
| b. Removal | f. Assembly |
| c. Disassembly | g. Installation |
| d. Cleaning, Inspection | |
-

INITIAL SETUP

Standard Tools

General mechanics tool kit
Electrical tool kit

Test Equipment

Multimeter, Appendix B, Item 4

Personnel

Electrician
Sheet metal worker

WARNING

Remove all electrical power from circuits before removing cable and receptacle assemblies.

TESTING

1. Set all circuit breakers to OFF position.
2. Using multimeter, check for continuity in cable, conduit, and receptacle assemblies.

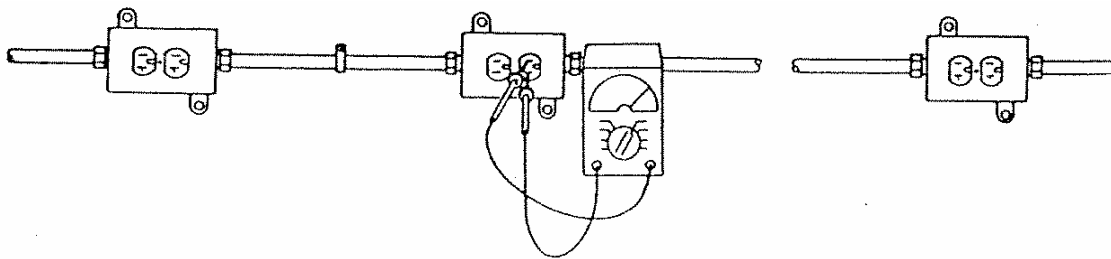

4-12. (cont)

REMOVAL

1. Open straps (1) securing conduit (2) to fixed sidewall.
2. Remove screws (3) and duplex receptacle covers (4).
3. Loosen captive screws (5) and move duplex receptacles (6) away from outlet boxes (7) as far as they will go.

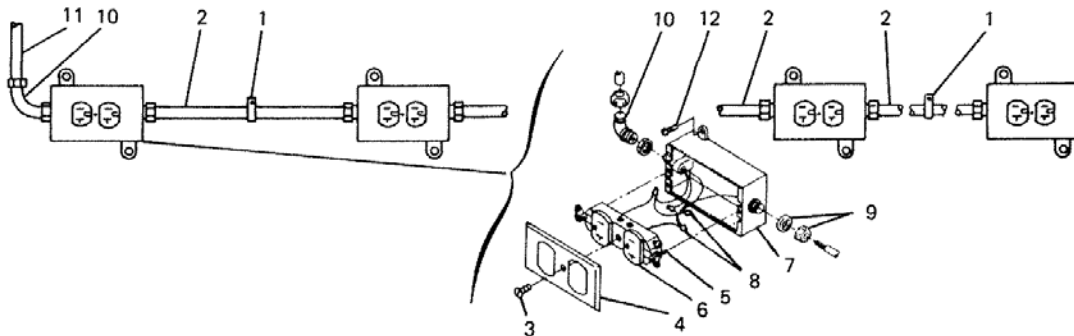

NOTE

Tag wires for reconnection.

4. Remove wire nuts (8) and disconnect wires from rear of duplex receptacles (6).
5. Disconnect connectors (9 and 10) and separate conduit (2 and 11) from outlet boxes (7).
6. Remove screws (12) and outlet boxes (7) from fixed sidewall.

DISASSEMBLY

1. Remove screws (1) and duplex covers (2).
2. Loosen captive screws (3) and move duplex receptacles (4) away from junction boxes (5) as far as they will go.

NOTE

Tag wires for reconnection

3. Remove wire nuts (8) and terminals, and disconnect wires from rear of receptacles (4), where applicable.

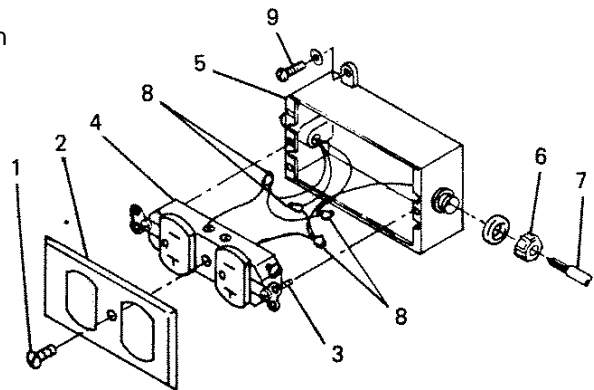

4-12. (cont)

NOTE

Tag wires for reconnection

4. Remove liquid tight connectors (6) from junction boxes (5) and separate connectors from electrical cords (7).
5. Remove screws (9) from junction boxes (5).

CLEANING, INSPECTION

1. Wipe cable and receptacle assembly and component surfaces.
2. Inspect mounting surfaces for corrosion and damage.
3. Inspect for and replace if necessary:
 - a. Missing or damaged components.
 - b. Corrosion or paint damage.

REPAIR

1. Repair or replace damaged wiring.
2. Corrosion or paint damage. (Refer to 4-37.)

ASSEMBLY

1. Install screws (9) in junction boxes (5).
2. Assemble liquid tight connectors (6) on electrical cords (7).
3. Install liquid tight connectors (6) in junction boxes (5).

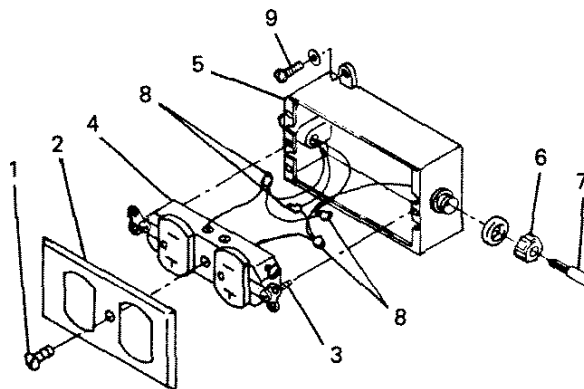

4-12. (cont)

4. Connect wires to receptacles (4) and attach wire nuts (8) and terminals, where applicable. (Refer to 4-40.)
5. Position receptacles (4) on junction boxes (5) and install screws (3).
6. Position covers (2) on duplex receptacles (4) and install screws (1).

INSTALLATION

1. Install outlet boxes (7) on fixed sidewall with screws (12).
2. Install conduit (2 and 11) in outlet boxes (7) with connectors (9 and 10).
3. Position duplex receptacles (6) near outlet boxes (7), connect wires, and secure with wire nuts (8). (Refer to 4-39 or 4-41.)
4. Position duplex receptacles (6) on outlet boxes (7) and tighten captive screws (5).
5. Position duplex receptacle covers (4) on outlet boxes (7) and install screws (3).
6. Secure conduit (2) to fixed sidewall with straps (1).

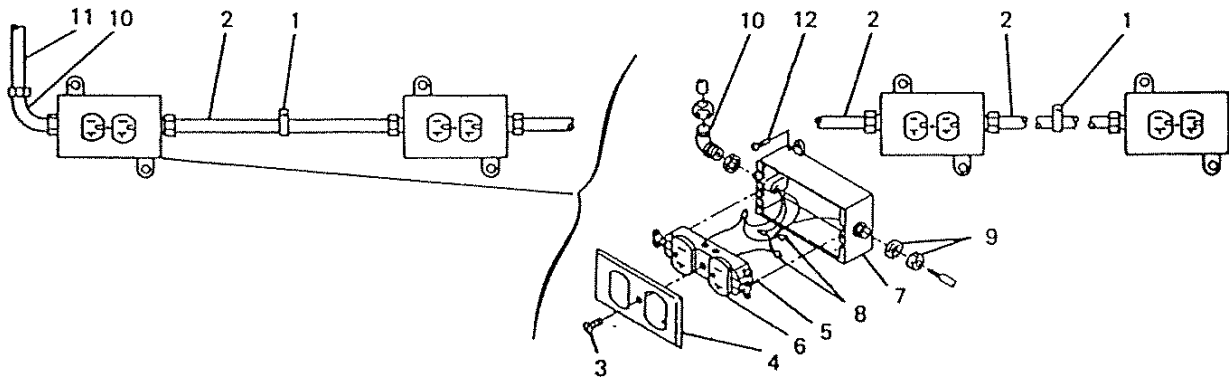

4-13. WALL SWITCH

This task covers.

- a. Removal
- b. Installation

INITIAL SETUP

Standard Tools

General mechanics tool kit
Electrical tool kit

Personnel

Electrician

REMOVAL

1. Set all circuit breakers and switches to OFF position.
2. Remove two screws (1) and switch cover (2).
3. Remove two screws (3) and carefully pull wall switch (4) out of switch box (5) as far as it will go.
4. Disconnect wires from wall switch (4).
5. Remove two screws (6), two lockwashers (7), and remove switch box (5) from wall.

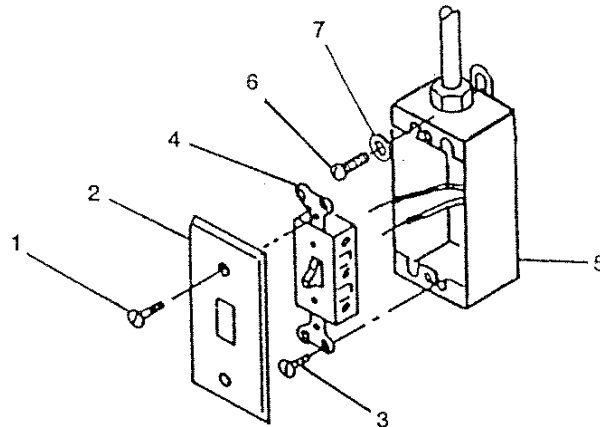

INSTALLATION

1. Position switch box (5) on wall and secure with screws (6)
2. Position wall switch (4) near switch box (5) and connect wires to rear of switch. (Refer to para 4-39 or 4-41.)
3. Position wall switch (4) in switch box (5) and secure with two screws (3).
4. Position switch cover (2) against switch box (5) and secure with two screws (1).

4-14. BLACKOUT SWITCH

This task covers.

- | | | | |
|----|----------------------|----|--------------|
| a. | Removal | d. | Installation |
| b. | Cleaning, Inspection | e. | Adjustment |
| c. | Repair | | |
-

INITIAL SETUP

Standard Tools

General mechanics tool kit
Electrical tool kit

Personnel

Electrician

Materials

Contact cleaner Item 26,
Appendix E

REMOVAL

1. Remove two screws (1) and switch cover (2).
2. Remove two screws (3) and pull switch (4) from outlet box (24) as far as it will go.

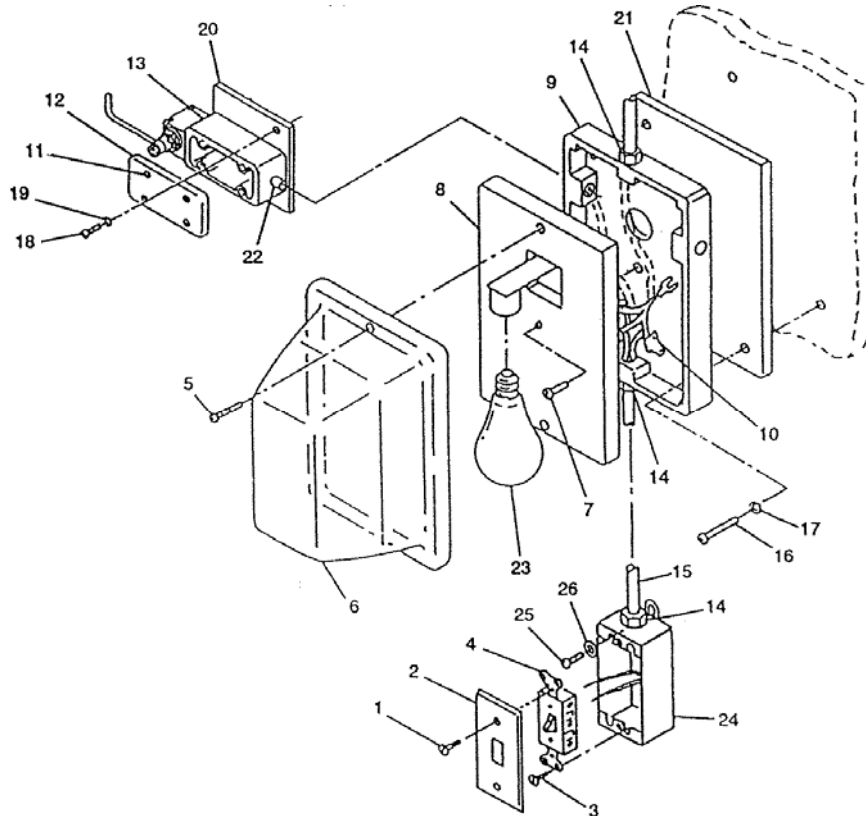

4-14. (cont)

NOTE

Tag wires for reconnection.

3. Disconnect wires at rear of switch (4).
4. Remove two screws (5) and light fixture cover (6). Remove bulb (23).
5. Remove screw (7) and separate light fixture (8) from light fixture adapter (9) as far as it will go.

NOTE

Tag wires for reconnection.

6. Remove wire nuts (10) and disconnect wires from rear of light fixture (8).
7. Loosen four captive screws (11) and remove limit switch cover (12).

NOTE

Tag wires for reconnection.

8. Disconnect three sets of wires plus one ground wire inside limit switch (13),

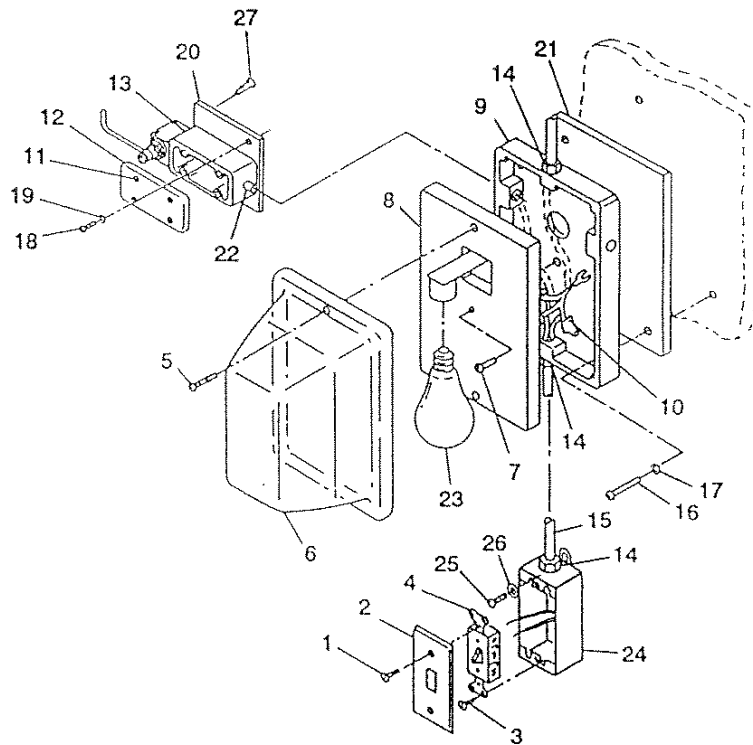

4-14. (cont)

9. Pull wires up through conduit (15) and into light fixture adapter (9).
10. Loosen two nipples (14) between light fixture adapter (9), and outlet box (24) and remove conduit (15).
11. Remove two screws (18) and lockwashers (19) from limit switch mounting plate (20).
12. Separate limit switch (13) from light fixture adapter (9) by unscrewing nipple (22).
13. Remove two screws (27) and separate limit switch (13) from limit switch mounting plate (20).

CLEANING, INSPECTION

1. Clean blackout switch and component surfaces with contact cleaner.
2. Inspect mounting surfaces for corrosion and damage.
3. Inspect for and replace if necessary:
 - a. Missing or damaged components.
 - b. Corrosion or paint damage.

REPAIR

Corrosion or paint damage. (Refer to para 4-37.)

INSTALLATION

1. Assemble limit switch (13) to limit switch mounting bracket (20) with two screws (27).
2. Assemble limit switch (13) to light fixture adapter (9) with nipple (22).

4-14. (cont)

3. Assemble limit switch (13) to endwall with two screws (18) and lockwashers (19).
4. Pass wires through nipples (14) and conduit (15) into light fixture adapter (9) and connect wires. (Refer to para 4-40.)
5. Pass wires from limit switch (13) through nipple (22) into light fixture adapter (9) and connect wires. (Refer to para 4-40.)
6. Connect wires in outlet box (24) to switch (4) and assemble switch to outlet box with two screws (3).
7. Assemble limit switch cover (12) to limit switch (13) by tightening four captive screws (11).
8. Assemble switch cover (2) to outlet box (24) with two screws (1).
9. Assemble light fixture (8) to light fixture adapter (9) with screw (7). Insert bulb (23).
10. Assemble light fixture cover (6) to light fixture (8) with two screws (5).

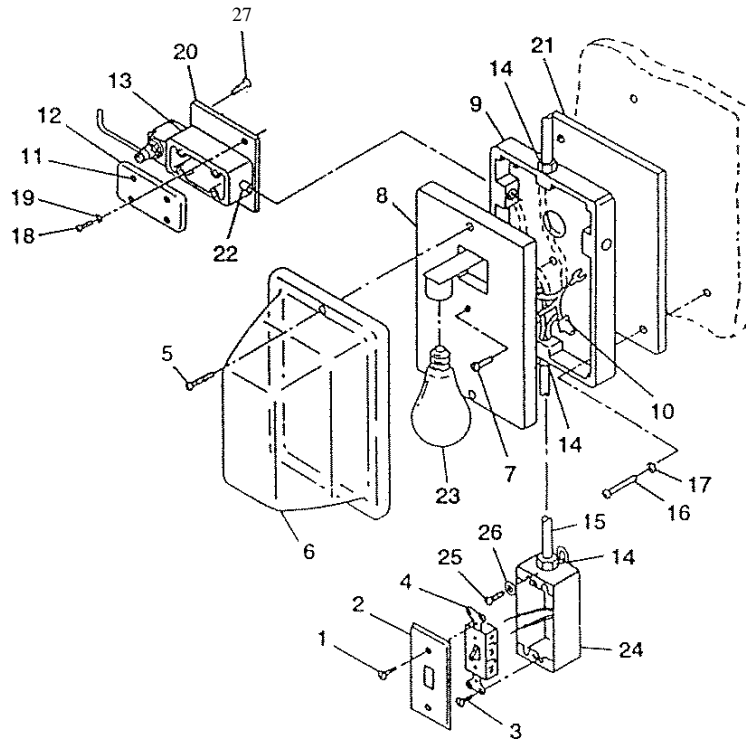

4-14. (cont)

ADJUSTMENT

There are three possible adjustments which can be made on the blackout switch.

1. Bend limit switch arm (1) towards or away from the endwall panel.
2. Loosen two setscrews (2) and slide limit switch arm (1) in or out of collar (3).
3. Loosen nut (4) and rotate collar (3) with limit switch arm (1) up or down.

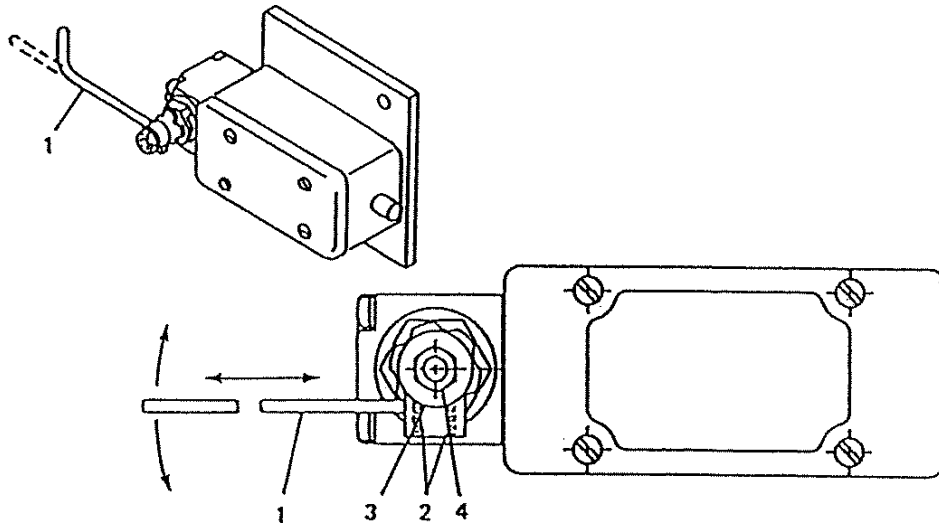

4-15. POWER PANEL ECU ASSEMBLY

This task covers.

- | | | | |
|----|----------------------|----|--------------|
| a. | Testing | d. | Repair |
| b. | Removal | e. | Assembly |
| c. | Disassembly | g. | Installation |
| d. | Cleaning, Inspection | | |
-

INITIAL SETUP

Standard Tools

General mechanics tool kit
Electrical tool kit

Personnel

Electrician

Test Equipment

Multimeter, Appendix B, Item 4

TESTING

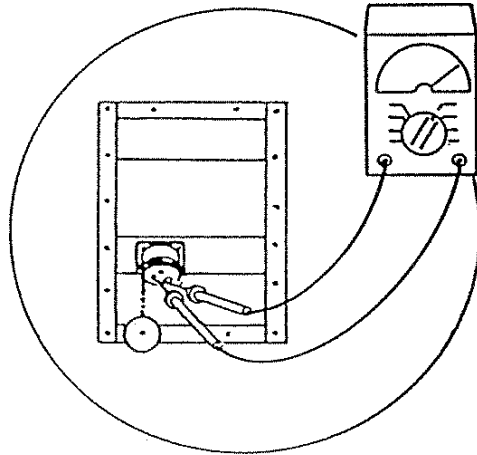

1. Connect site power.
2. Unscrew connector cover from connector.
3. Set all circuit breakers in ON position.
4. Using multimeter, check for proper voltage at each receptacle pin.
5. If improper voltage is present, replace defective receptacles, terminals/connectors, or panel wiring.

WARNING

Turn off all circuit breakers before removing power panel ECU assembly.

4-15. (cont)

REMOVAL

1. Inside shelter, remove screws (1), lockwashers (2), and washers (3), and carefully lift cover assembly (4) away from rear endwall panel as far as it will go.

NOTE

Tag all wires for reconnection.

2. Disconnect wires at receptacle (5), and terminals/connector from back of power panel ECU assembly (6).
3. Outside shelter, drill out rivets (7) and remove power panel ECU assembly (6) from rear endwall panel. (Refer to para 4-26.)

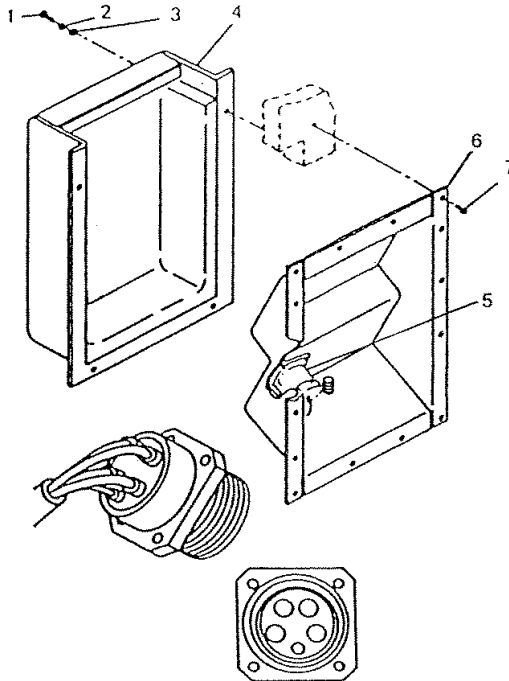

DISASSEMBLY

1. Remove screws (1), nuts (2), washer (3), and receptacle cover (4).
2. Remove receptacle (5) from panel (6).

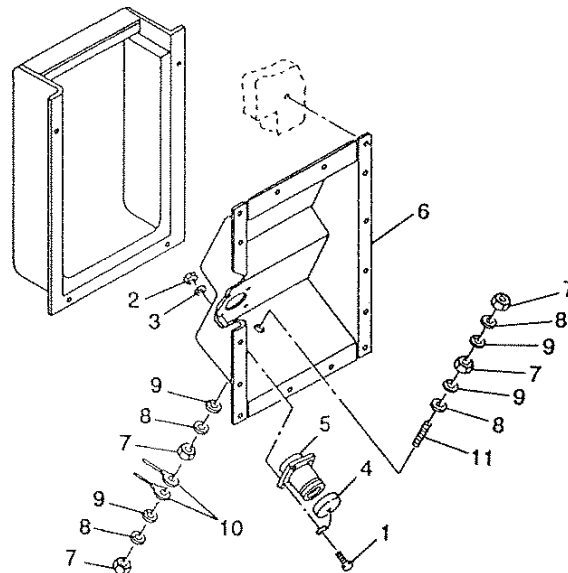

4-15. (cont)

3. Remove four nuts (7), four lockwashers (8), four washers (9), two terminal ground lugs (10), and threaded stud (11) from panel (6).

CLEANING, INSPECTION

1. Wipe power panel ECU and component surfaces.
2. Inspect mounting surfaces for corrosion and damage.
3. Inspect receptacle for damage, binding post, terminal, or threaded stud.

REPAIR

1. Replace damaged receptacle, binding post, terminal, or threaded stud.
2. Repair corrosion or paint damage. (Refer to para 4-37.)

ASSEMBLY

1. Install threaded stud (11), two ground terminal lugs (10), four washers (9), four lockwashers (8), and four nuts (7) in panel (6).
2. Using crimping tool, attach wires to receptacle pins. (Refer to para 4-39 or 4-41.)
3. Install receptacle (5) in panel (6) and secure with screws (1), receptacle cover (4), lockwasher (3), and nut (2).

4-15. (cont)

INSTALLATION

1. Position power panel ECU assembly (6) against outside of front endwall panel and secure with rivets (7). (Refer to para 4-26.)
2. Connect wires to receptacle (5) at rear of power entry panel assembly (6). (Refer to para 4-39 or 4-41.)
3. Position cover assembly against inside of rear endwall panel and secure with screws (1), lockwashers (2), and washers (3).
4. Reconnect electrical power to service entrance receptacle.

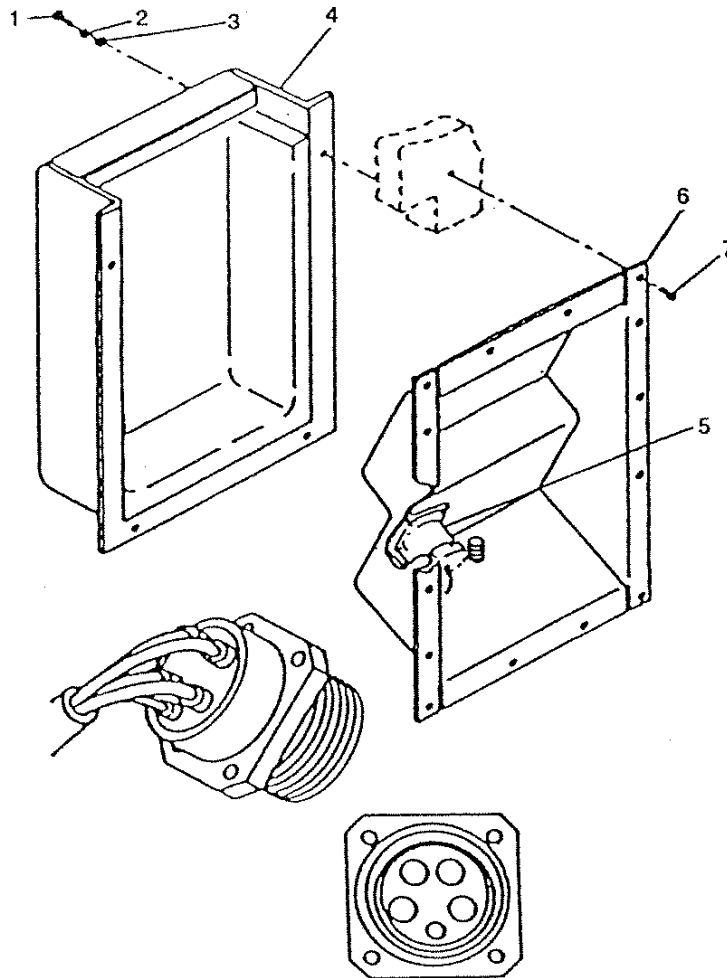

4-16. (cont)

REMOVAL

NOTE

This portion of the procedure is applicable to both models of circuit breaker panels. Older models (NQOB) allow individually removing the panel cover or the panelboard. Newer model (NQOD) has the panel cover and panelboard attached and is removed as a single unit.

1. Open circuit breaker panel doors (1).
2. On model NQOB, loosen four captive screws (2) and move four clamp fingers (3) to the OPEN position.
3. On model NQOB, lift panel cover (4) from the circuit breaker panelboard (8).
4. On both models, remove four screws (6) and washers (7) and lift panelboard (8) from circuit breaker box (5).

NOTE

Tag wires for reconnection.

5. Disconnect wires in circuit breaker box (5).
6. Loosen two captive screws (9) and remove conduit outlet cover (10) from conduit outlet body (11).

NOTE

Tag wires for reconnection.

7. Disconnect wires in conduit outlet body (11).
8. Remove nine screws (12) and three ceiling light covers (13).

4-16. (cont)

NOTE

Tag wires for reconnection.

9. Disconnect wires in each of three ceiling lights (14).
10. Remove screws (15) and receptacle covers (16).
11. Loosen captive screws (17) and remove receptacles (18) from outlet boxes (19) as far as they will go.

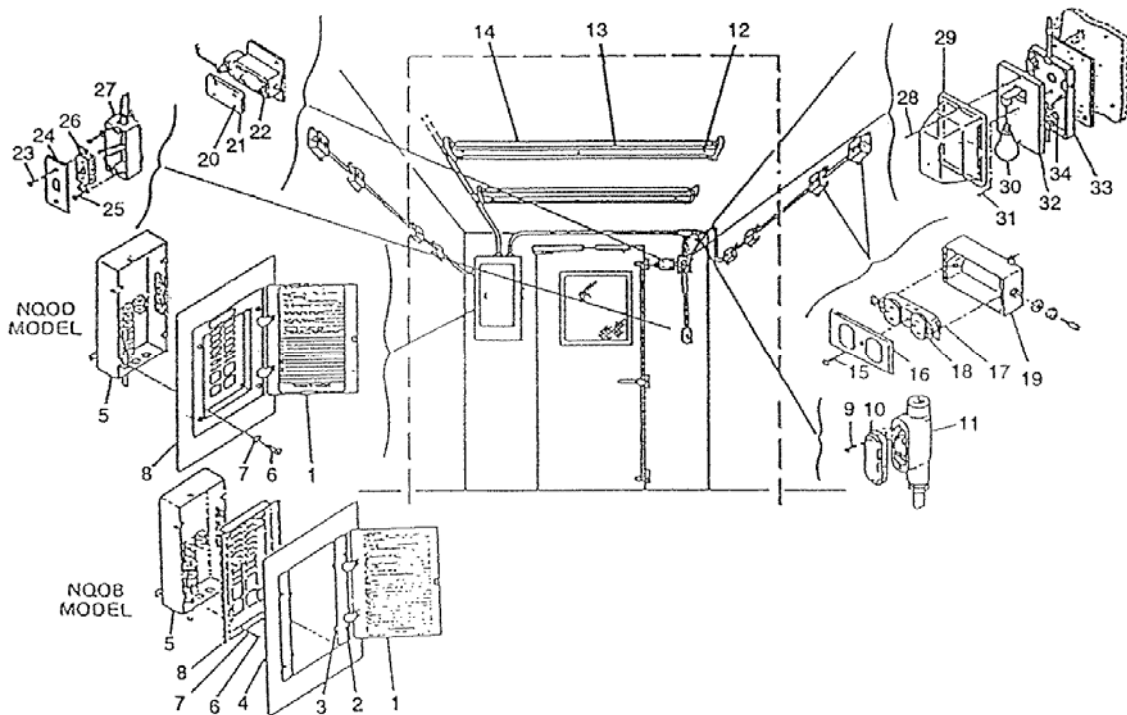

NOTE

Tag wires for reconnection.

12. Disconnect wires at rear of receptacles (17).
13. Loosen four captive screws (20) and remove limit switch cover (21) from limit switch (22).
14. Disconnect wires in limit switch (22).

4-16. (cont)

NOTE

Tag wires for reconnection.

15. Remove two screws (23) and remove switch cover (24).
16. Remove two screws (25) and remove switch (26) from outlet box (27) as far as it will go.

NOTE

Tag wires for reconnection.

17. Disconnect wires from switch (26).
18. Remove two screws (28) and light fixture cover (29). Remove bulb (30).
19. Remove screw (31) and separate light fixture (32) from light fixture adapter (33) as far as it will go.

NOTE

Tag wires for reconnection.

20. Remove wire nuts (34) and disconnect wires from light fixture (32).
21. Remove wires from electrical conduits.

INSTALLATION

1. Pull wires through electrical conduits.
2. Connect wires to light fixture (32) and attach wire nuts (34). (Refer to para 4-39 or 4-41.)
3. Assemble light fixture (32) to light fixture adapter (33) with screw (31).
4. Install bulb (30). Assemble light fixture cover (29) to light fixture (32) with two screws (28).
5. Connect wires to switch (26). (Refer to para 4-39 or 4-41.)
6. Install switch (26) in outlet box (27) and secure with two screws (25).
7. Assemble switch cover (24) to outlet box (27) with two screws (23).

4-16. (cont)

8. Connect wires to limit switch (22). (Refer to para 4-39 or 4-41.)
9. Assemble limit switch cover (21) to limit switch (22) by tightening four captive screws (20).
10. Connect wires to rear of receptacles (18). (Refer to para 4-39 or 4-41.)
11. Install receptacles (18) in outlet boxes (19) and tighten two captive screws (17).

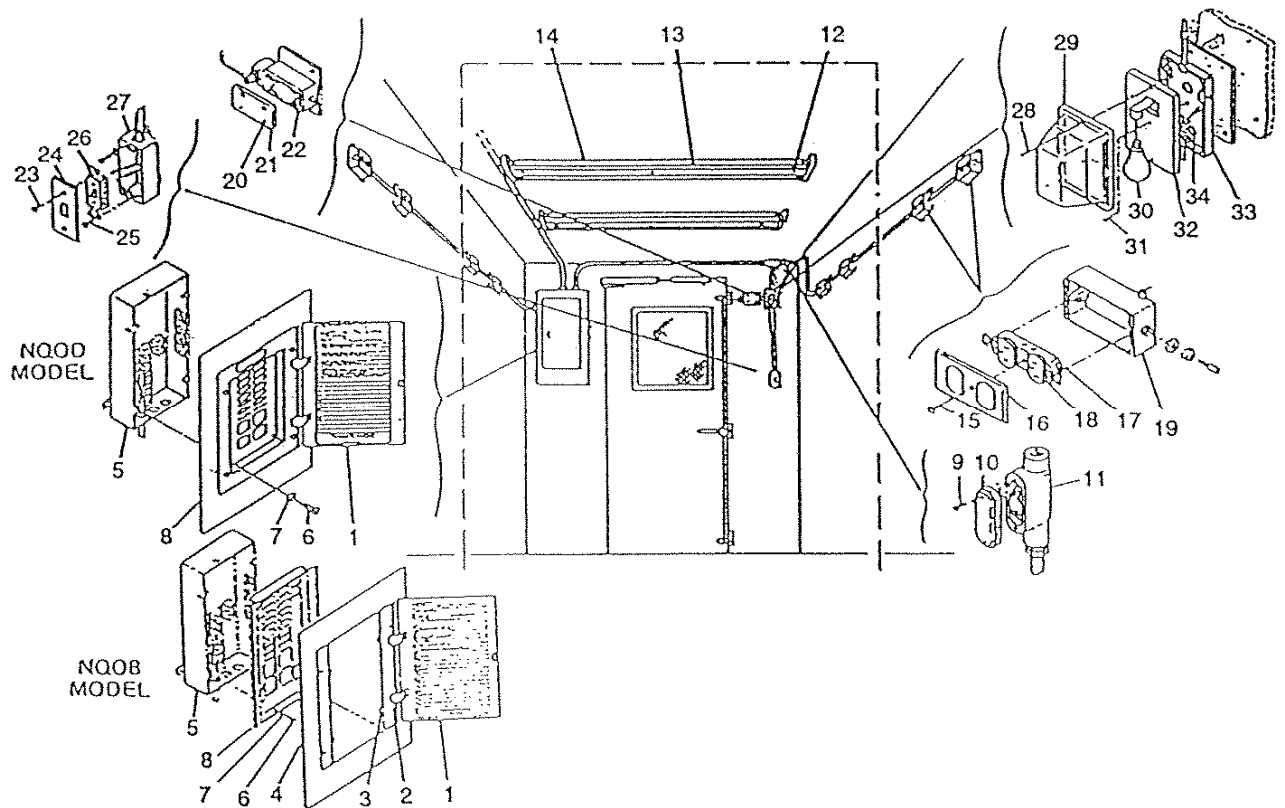

12. Attach duplex receptacle covers (16) to outlet boxes (19) with screws (15).
13. Connect wires to each of three ceiling lights (14). (Refer to para 4-39 or 4-41.)

4-16. (cont)

14. Attach three ceiling light covers (13) to three ceiling lights (14) with nine screws (12).
15. Connect wires to conduit outlet body (11). (Refer to para 4-39 or 4-41.)
16. Attach conduit outlet cover (10) to conduit outlet body (11) by tightening two captive screws (9).
17. Connect wires to circuit breaker box (5). (Refer to para 4-39 or 4-41.)
18. On both models, position panel board (8) over circuit breakers in circuit breaker box (5) and secure with four screws (6) and washers (7).
19. On Model NQOB, install panel cover (4) on the circuit breaker panelboard (8), move four clamp fingers (3) to the CLOSE position and tighten captive screws (2).
20. Close circuit breaker panel door (1).

4-16.1 RACEWAY ASSEMBLY AND WIRING

This task covers.

- | | |
|-------------------------|---------------------------|
| a. Testing | d. Repair |
| b. Removal, Disassembly | e. Assembly, Installation |
| c. Cleaning, Inspection | |
-

INITIAL SETUP

Standard Tools

General mechanics tool kit
Electrical tool kit

Personnel - 2

Electricians

Test Equipment

Multimeter, Appendix B, Item 4

WARNING

Wiring contains voltage that is dangerous if contacted. Before replacing wiring, make sure all circuit breakers and switches are set to OFF position.

TESTING

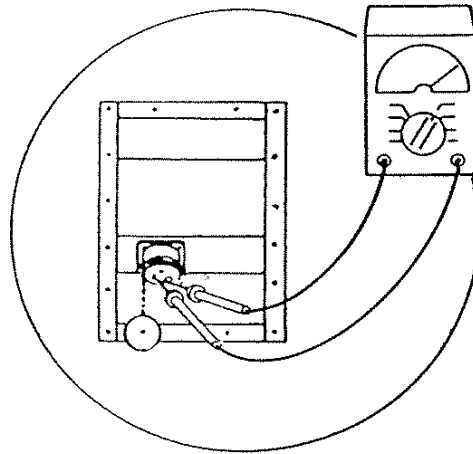

1. Connect site power.
2. Unscrew connector cover from connector.
3. Set all circuit breakers in ON position.
4. Using multimeter, check for proper voltage at each receptacle pin.
5. If improper voltage is present, replace defective receptacle, terminals/connectors, panel wiring, or raceway wiring.

4-16.1 (cont)

WARNING

Turn off all circuit breakers before removing raceway assembly.

REMOVAL, DISASSEMBLY

1. Remove power panel off personnel endwall. (Refer to para 4-7.)
2. Remove ECU panel front endwall. (Refer to para 4-15.)

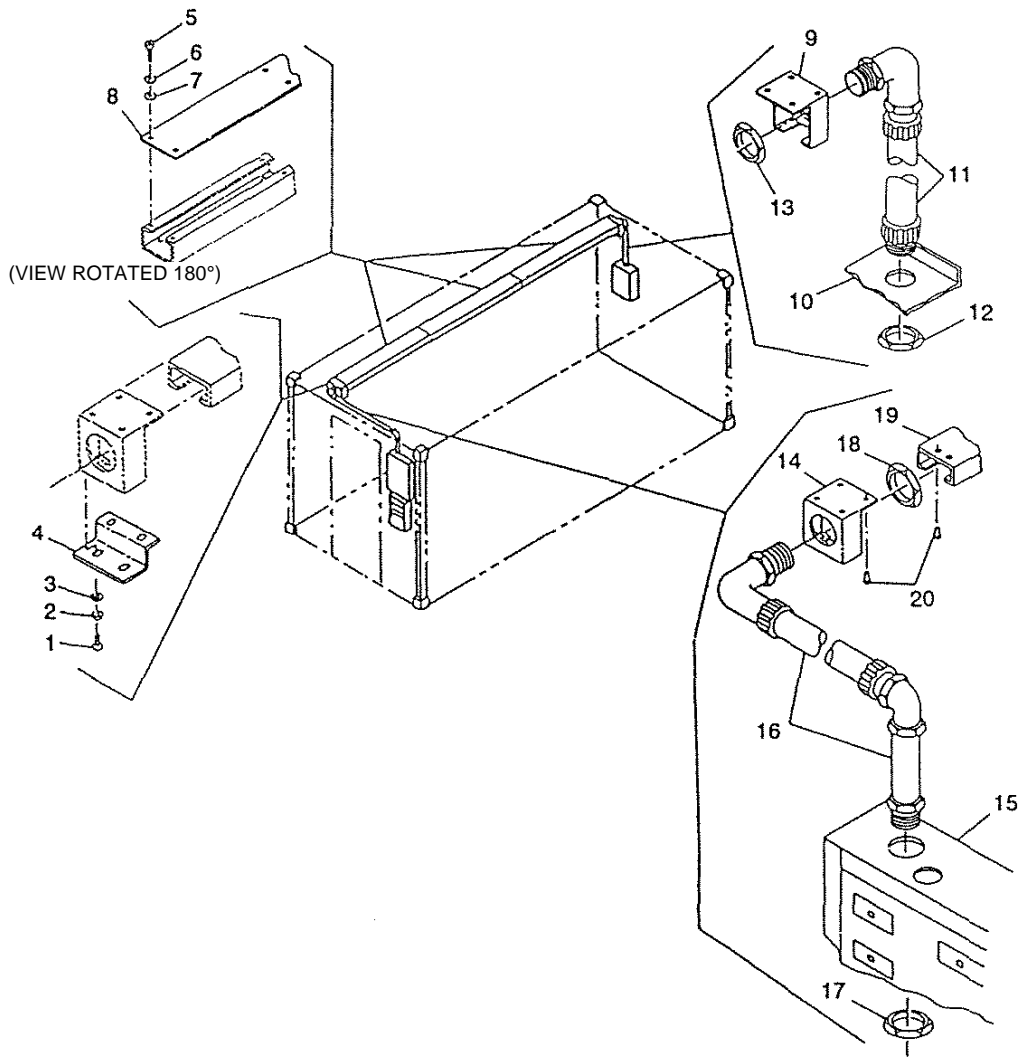

4-16.1 (cont)

3. Remove four screws (1), four lockwashers (2), and four washers (3), then remove one conduit outlet cover (4).
4. Remove thirty four screws (5), thirty four lockwashers (6), and thirty four washers (7), then remove three raceway covers (8).

NOTE

Tag all wires for reconnection

5. Carefully pull wiring from conduit outlet (9), out of power panel ECU spacer (10), up through conduit (11), located on rear endwall.
6. Remove one conduit nut (12), from power panel ECU spacer (10).
7. Remove one conduit nut (13), from conduit outlet box (9).

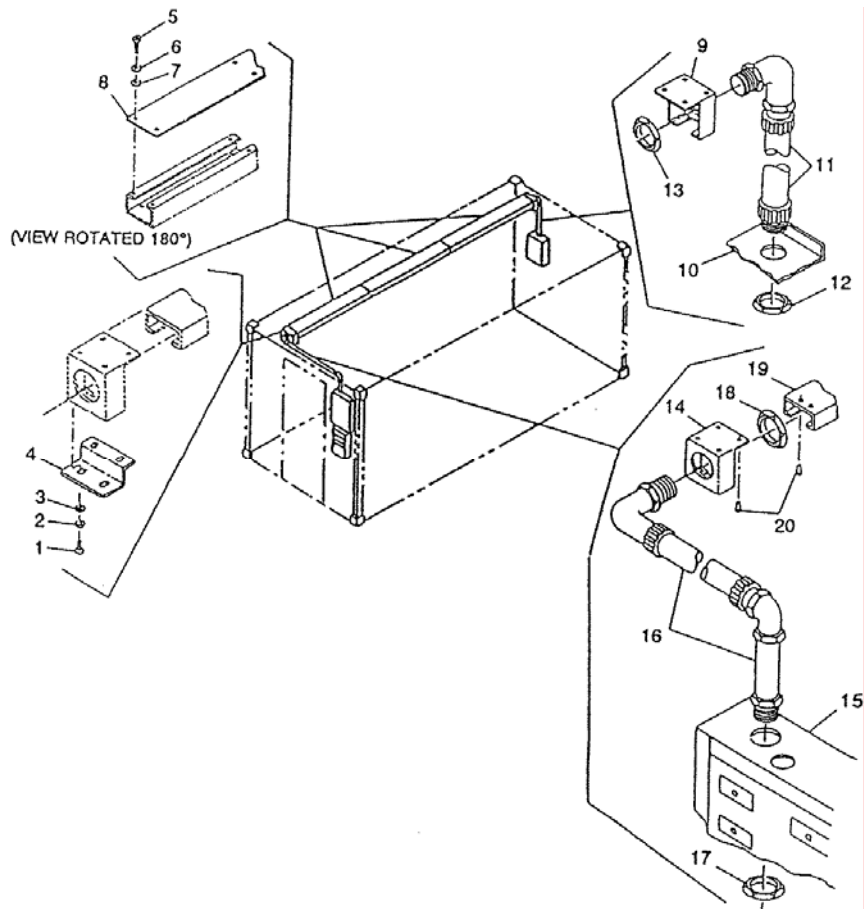

4-16.1 (cont)

REMOVAL, DISASSEMBLY

8. Carefully pull wiring from conduit outlet (14), out of power entry panel (15), and through conduit (16).
9. Remove one conduit nut (17) from power entry panel (15).
10. Remove one conduit nut (18) from conduit outlet box (14).
11. Then carefully remove wiring from raceway assemblies (19).
12. Drill out thirty four rivets (20) and remove raceway assemblies (19), and two conduit outlet boxes (9) and (14) from roof panel.
13. Remove conduit (11) and (16) from front and rear panels.

CLEANING, INSPECTION

1. Wipe down raceways, conduit outlets and conduits.
2. Inspect mounting surfaces for corrosion or damage.
3. Inspect raceways, conduit outlets, conduit and wiring for damage.

REPAIR

1. Replace damaged raceway, conduit outlets or conduit.
2. Repair corrosion or paint damage. (Refer to para 4-37.)

ASSEMBLY, INSTALLATION

1. Replace conduit (11) and (16) in front and rear panels and secure with conduit nuts (12) and (17).
2. Replace raceway assemblies (19) and conduit outlets (9) and (14) and secure with rivets (20) to roof panel. (Refer to para 4-26.)

4-16.1 (cont)

ASSEMBLY, INSTALLATION

3. Replace conduit nuts (13) and (18).
4. Pull wiring through conduit outlet (14), conduit (16), and into power entry panel (15) on front endwall.
5. Replace wiring in raceway assemblies (19).
6. Pull wiring through conduit outlet (9), conduit (11), and through power panel ECU spacer (10).
7. Replace raceway covers (8) and secure with washers (7), lockwashers (6), and screws (5).
8. Replace conduit outlet covers (4) and secure with washers (3), lockwashers (2), and screws (1).

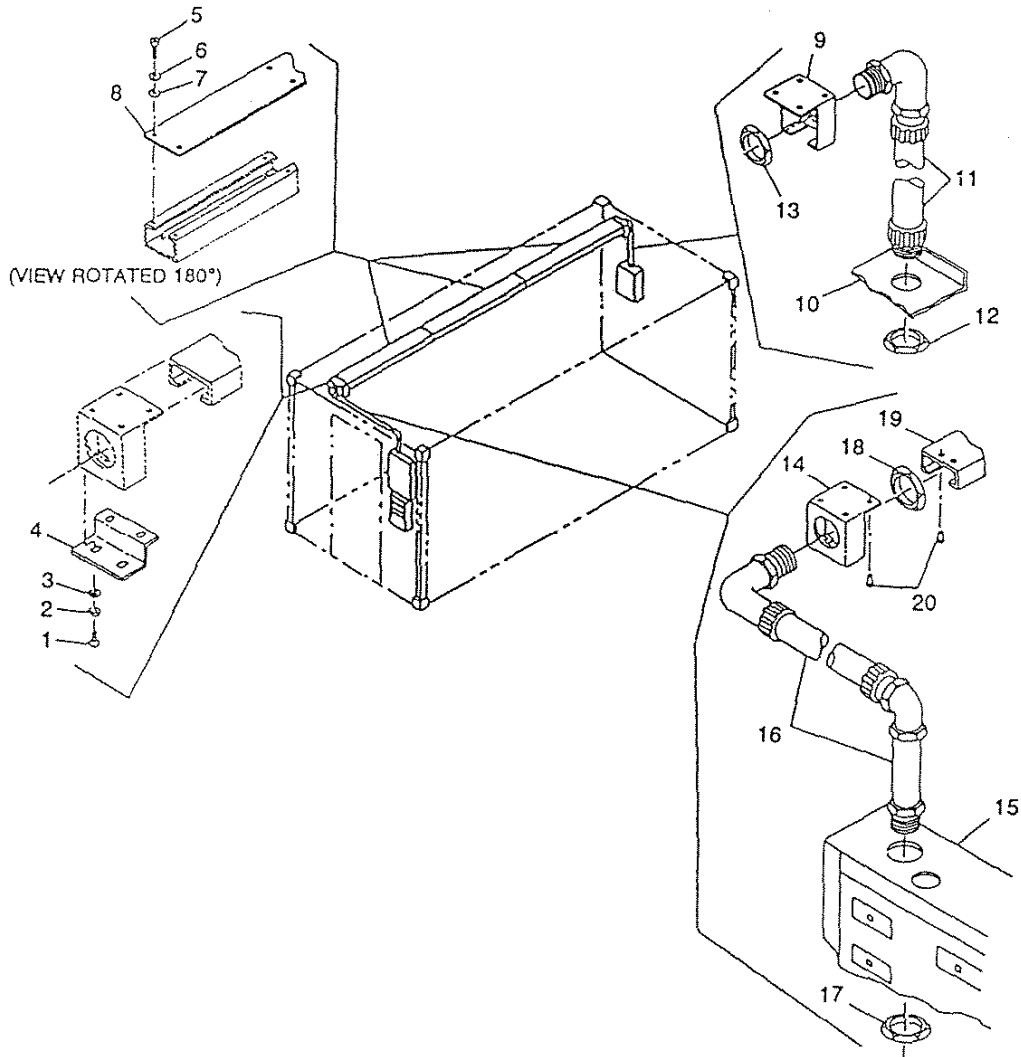

ASSEMBLY, INSTALLATION

9. Replace ECU panel front endwall. (Refer to para 4-15.)
10. Replace power panel personnel endwall. (Refer to para 4-7.)
11. Reconnect electrical power to service entrance receptacle.
12. Turn all circuit breakers and switches to ON position.

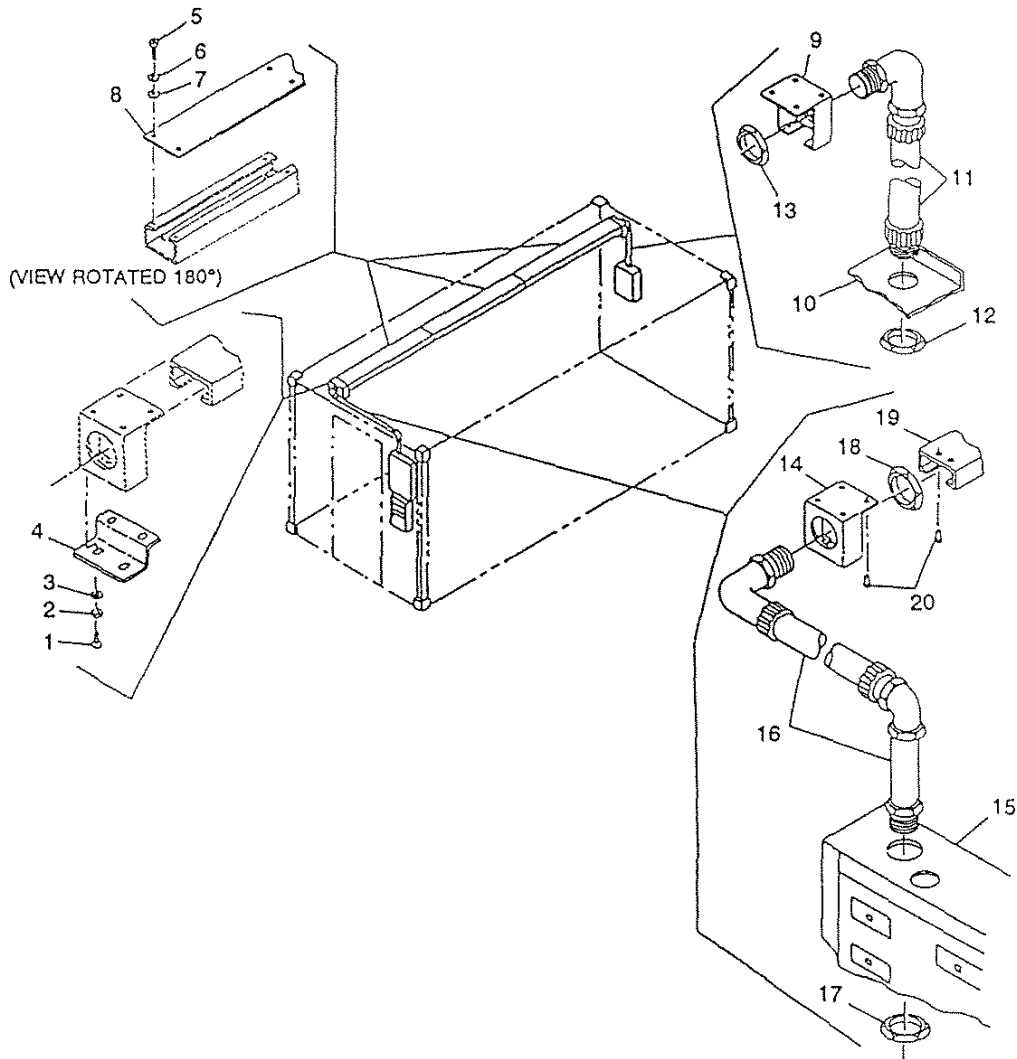

4-17. Personnel Door

This task covers:

- | | |
|--------------------------|-----------------|
| a . Removal | e. Assembly |
| b . Disassembly | f. Installation |
| c . Cleaning, Inspection | g. Alignment |
| d . Repair | |
-

INITIAL SETUP

Special Tools

Hand blind riveter, Appendix B, Item 2

Personnel – 2

Materials

Sealing Compound, Item 19

Appendix E

Standard Tools

General mechanics tool kit

REMOVAL

Personnel Door

- 1 . Remove hairpin (1), and pin (2), and swing back bracket (3).
2. Close door (4).
3. Remove four bolts (5), lockwashers (6), and washers (7) securing each of four hinge base plates (8) to endwall.

4-17. (cont)

Door Vent

4. Drill out rivets (9) and remove four vent retainer strips (10). (Refer to 4-26.)
5. Drill out rivets (11) and remove retainer strip (12) and rain strip (13). (Refer to 4-26.)
6. Drill out rivets (14) and remove door vent (15). (Refer to 4-26.)

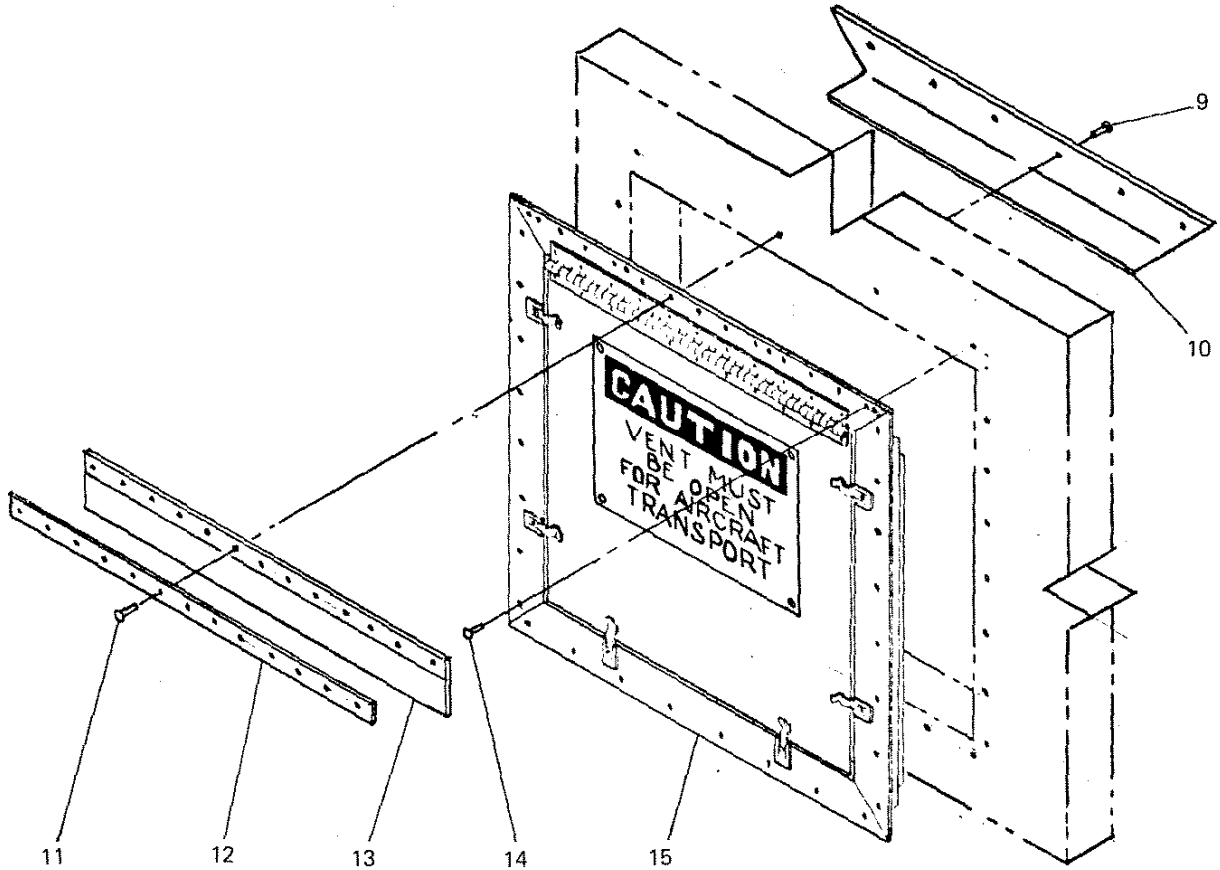

Door Lock Assembly

7. Remove three retaining rings (16), four flanged beatings (17), and top rod (18).
8. Remove four screws (32), four bolts (33), lockwashers (34), washers (35), mounting plates (36 and 37), and screw (38).
9. Remove nuts (19), washers (20 and 21), latch arms (22), spacers (23), and pins (24).

4-17. (cont)

10. Drive out dowel pins (25 and 26) and remove inside handle (27), latch arm (28), washer (29), pin (30) and bottom rod (31).
11. Repeat steps 7 through 10 to remove lower latch arm.
12. Drive out dowel pin (39) and remove outside handle (40) and washers (41).
13. Drill out rivets (42) and remove pan (43). (Refer to 4-26).
14. Remove flanged bearings (44) and shafts (45 and 46).
15. Drill out rivet (47) and remove washer (48) and spacers (49).
16. Drive out dowel pins (50) and remove rollers (51) and roller extensions (52).

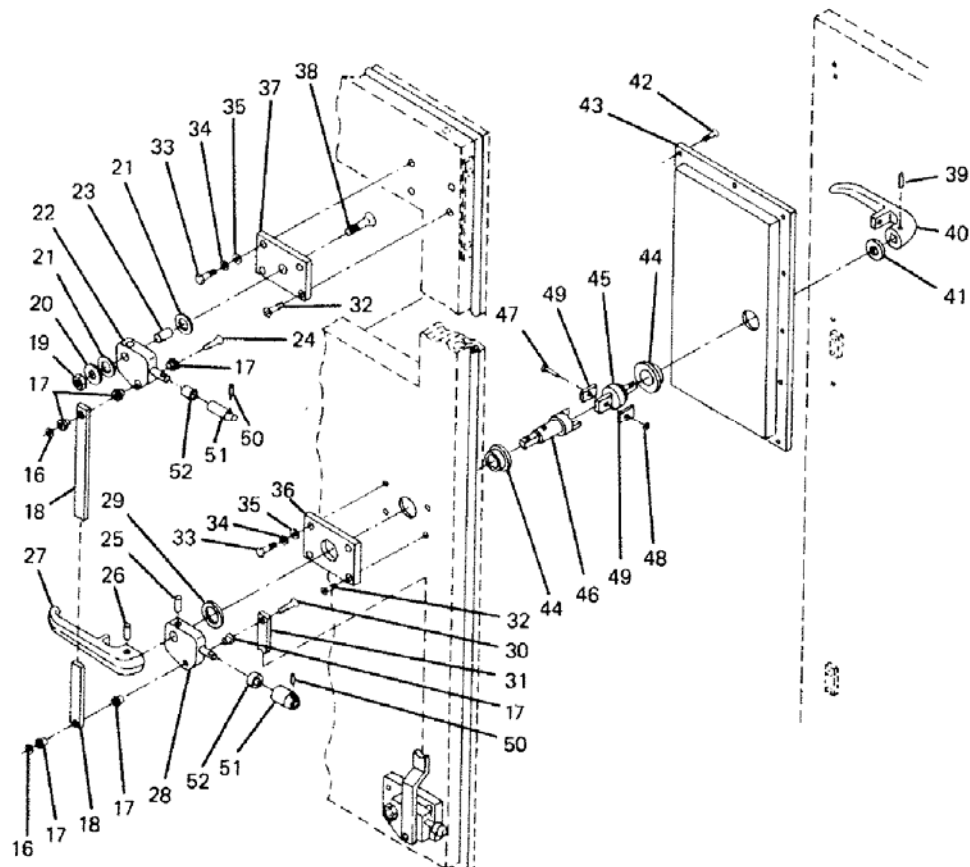

Door Stop Assembly

17. Remove six bolts (53 and 54), lockwashers (55), and washers (56).
18. Remove door stop assembly (57) from door.

4-17. (cont)

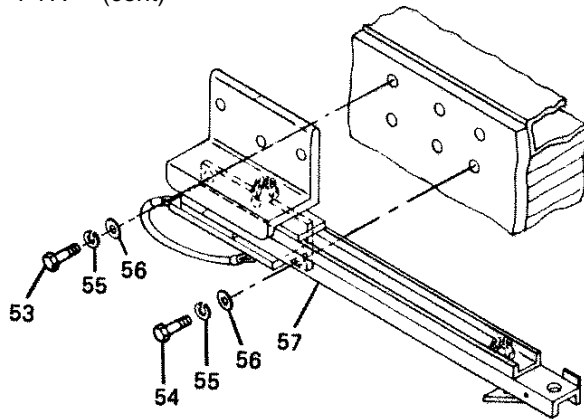

DISASSEMBLY

Personnel Door

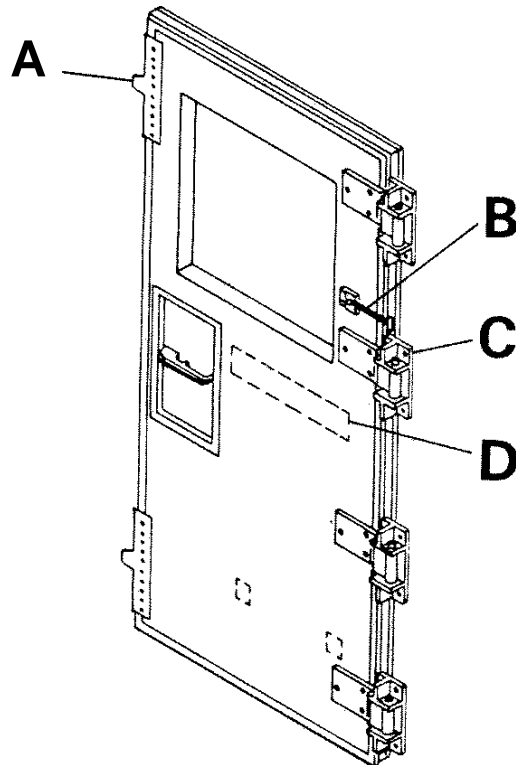

4 - 17. (cont)

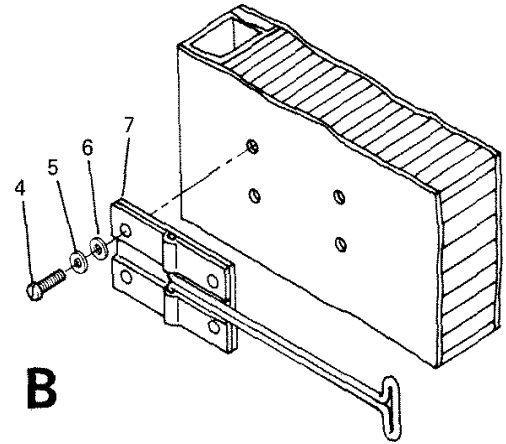
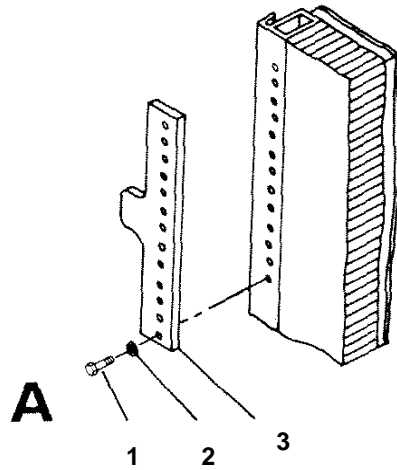

1. Remove screws (1) and lock-washers (2) securing personnel door shear plate (3) to door.
2. Remove screws (4), lock-washers (5), and washers (6) securing door holder (7) to door.
3. Remove bolts (8), lockwashers (9), and washers (10) securing hinge (11) to door.
4. Remove screws (12) and lockwashers (13) securing jack storage bracket (14) to door.
5. Remove screws (15) securing jack support bracket (16) and spacer (17) to door.

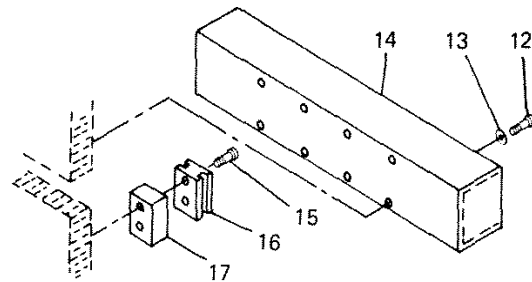
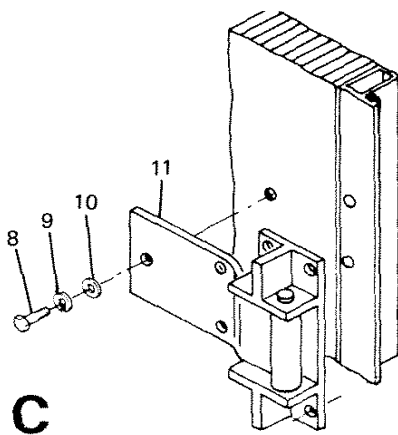

4-17. (cont)

Door Vent

6. Remove screws (18), lockwashers (19), and washers (20) securing filter frame (21) and filter (22) to vent frame (23).
7. Drill out rivet (24) and remove fastener (25). (Refer to 4-26.)
8. Drill out rivets (26) and remove hinge (27). (Refer to 4-26.)
9. Drill out rivets (28) and remove door vent (29), retainer strips (30), and curtain (31). (Refer to 4-26.)
10. Remove bolts (32), washers (33), and spring (34).
11. Drill out rivets (35) and remove caution plate (36).

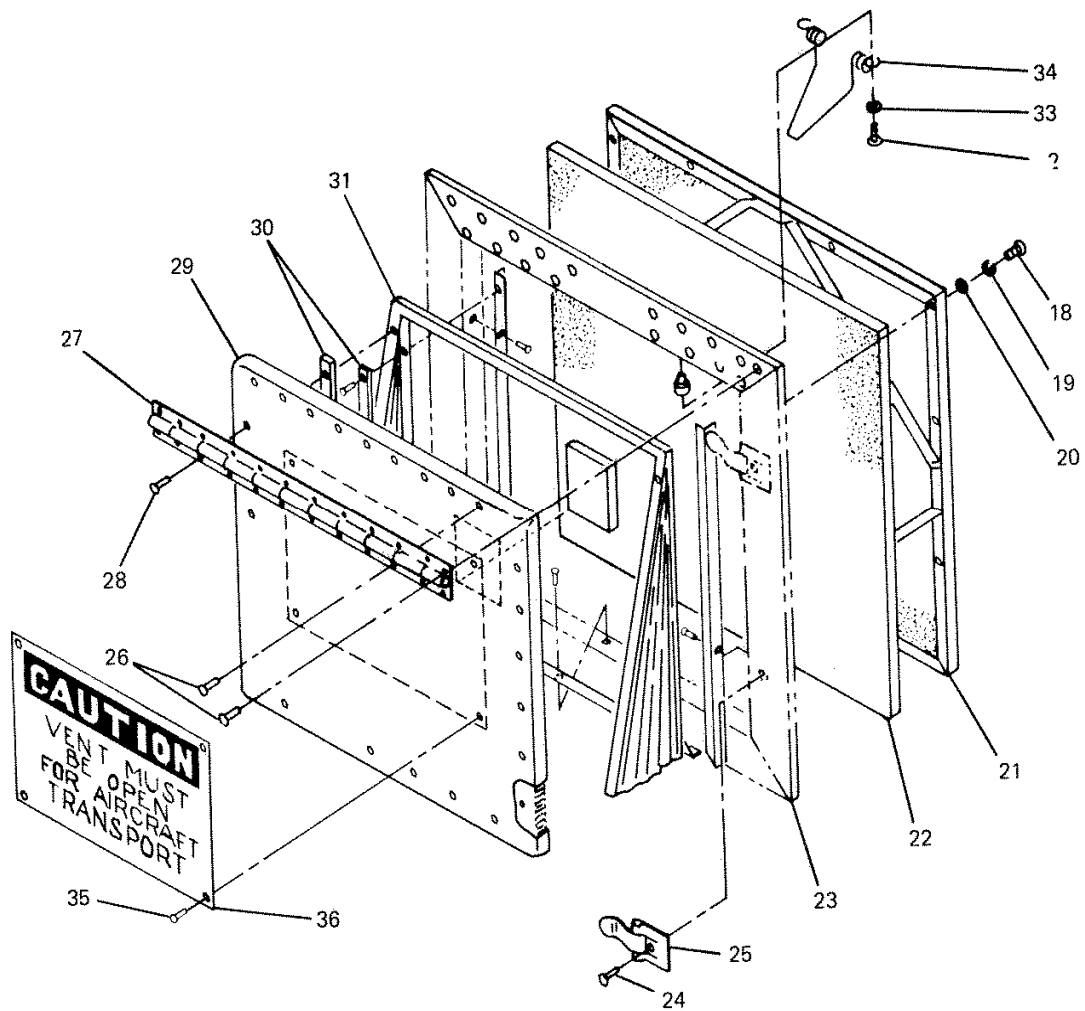

4-17. (cont)

Door Stop Assembly

12. Remove hair pin (37), pin (38), and bracket (39).
13. Drill out rivet (40) to remove lanyard (41). (Refer to 4-26.)
14. Remove cotter pin (42), nut (43), washers (44), and bolt (45) securing bracket (46) to upper brace (47).
15. Remove cotter pin (48), nut (49), washers (50), nylon washer (51), and bolt (52) securing upper brace (47) to lower brace (53).
16. Compress spring (54) with catch (55) and drive out roll pin (56).

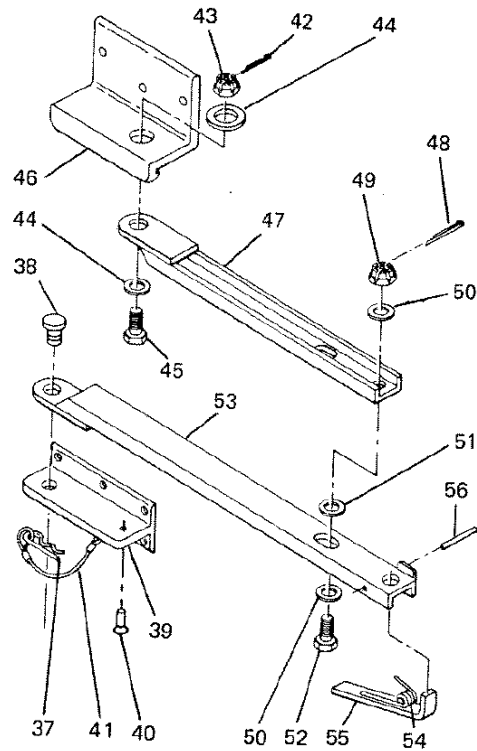

CLEANING, INSPECTION

1. Wipe panel and component surfaces.
2. Inspect mounting surfaces for corrosion and damage.
3. Inspect for and replace if necessary:
 - a. Missing or damaged components
 - b. Corrosion or paint damage.

REPAIR

1. Panel skin damage. (Refer to 4-25 through 4-36.)
2. Corrosion or paint damage. (Refer to 4-37.)

ASSEMBLY

Door Stop Assembly

1. Position catch (55) and spring (54) in lower brace (53) and install roll pin (56).
2. Install bolt (52), washers (50), nylon washer (51), nut (49), and cotter pin (48) securing lower brace (53) to upper brace (47).
3. Install bolt (45), washers (44), nut (43), and cotter pin (42), securing upper brace (47) to bracket (46).

4-17. (cont)

4. Position lanyard (41) on bracket (39) and install rivet (40). (Refer to 4-26.)
5. Insert pin (38) through lower brace (53) and bracket (39) and install hair pin (37).
6. Refinish. (Refer to para 4-37.)

Door Vent

7. Position spring (34) and install washers (33) and bolts (32).
8. Assemble curtain (31), retainer strips (30), and door vent (29) and install rivets (28). (Refer to 4-26.)
9. Position hinge (27) and install rivets (26). (Refer to 4-26.)
4. Position fastener (25) and install rivet (24). (Refer to 4-26.)
5. Assemble vent frame (23), filter (22), and filter frame (21) and install washers (20), lockwashers (19), and screws (18).
6. Apply sealing compound to rear of caution plate (36), place against door vent (29) and install rivets (35). (Refer to 4-26.)

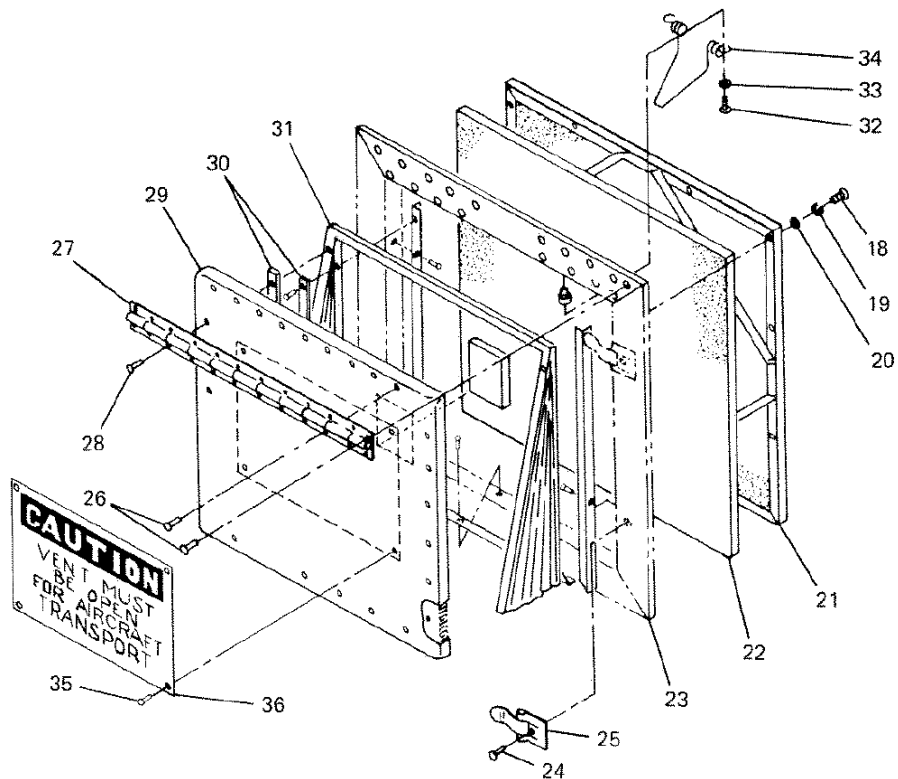

4-17. (cont)

Personnel Door

13. Position spacer (17) and jack support bracket (16) on door and install screws (15).
14. Position jack storage bracket (14) on door and install lock-washers (13) and screws (12).

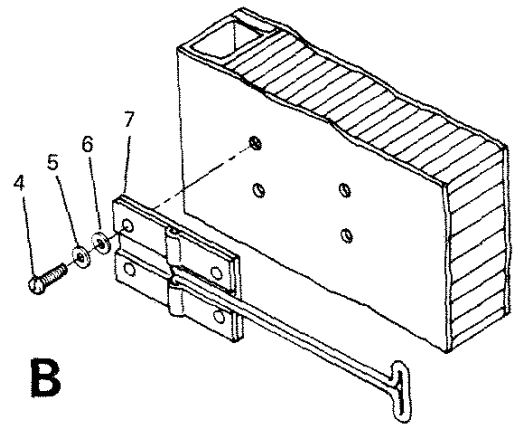
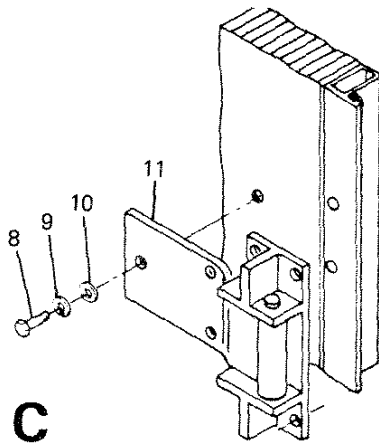
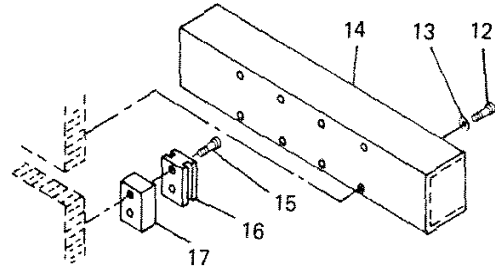

15. Position hinge base plate (11) on door and install washers (10), lock washers (9) and bolts (8).
16. Position door holder (7) on door and install washers (6), lockwashers (5), and screws (4).

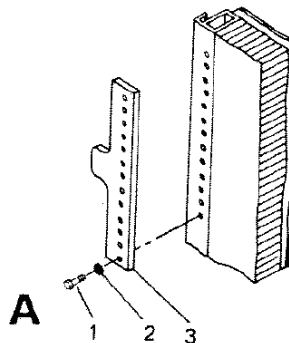

17. Position personnel shear plate (3) on door and install lockwashers (2) and screws (1).
18. Seal. (Refer to para 4-36.)
19. Refinish. (Refer to para 4-37.)

4-17. (cont)

INSTALLATION

Door Stop Assembly

1. Attach door stop (57) to door with six washers (56), lockwashers (55), and bolts (53 and 54).

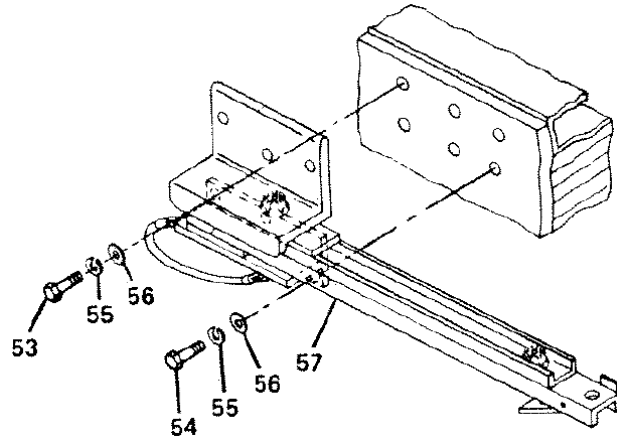

Door Lock Assembly

2. Install roller extensions (52), rollers (51), and dowel pins (50).

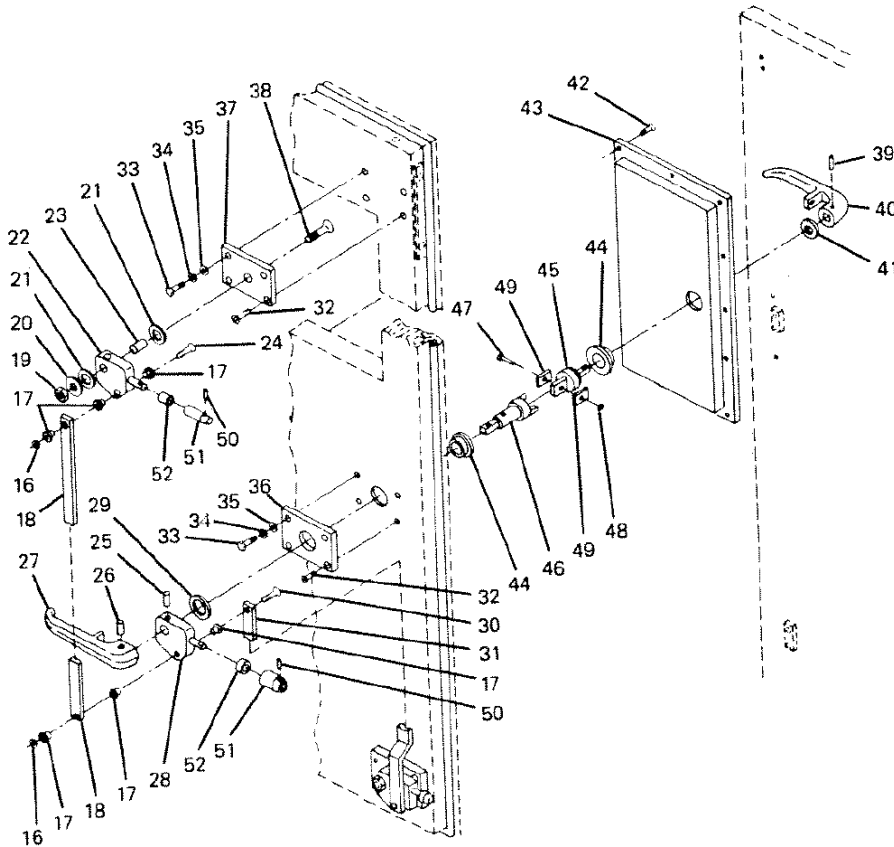

3. Install spacers (49), washer (48), and rivet (47). (Refer to 4-26.)
4. Install shafts (46 and 45) and flanged bearings (44) in door panel.
5. Position pan (43) and install rivets (42). (Refer to 4-26.)

4-17. (cont)

6. Position washer (41) and outside handle (40) and install dowel pin (39).
7. Insert screw (38) in mounting plate (37) and install washers (35), lockwashers (34), bolts (33), and screws (32).

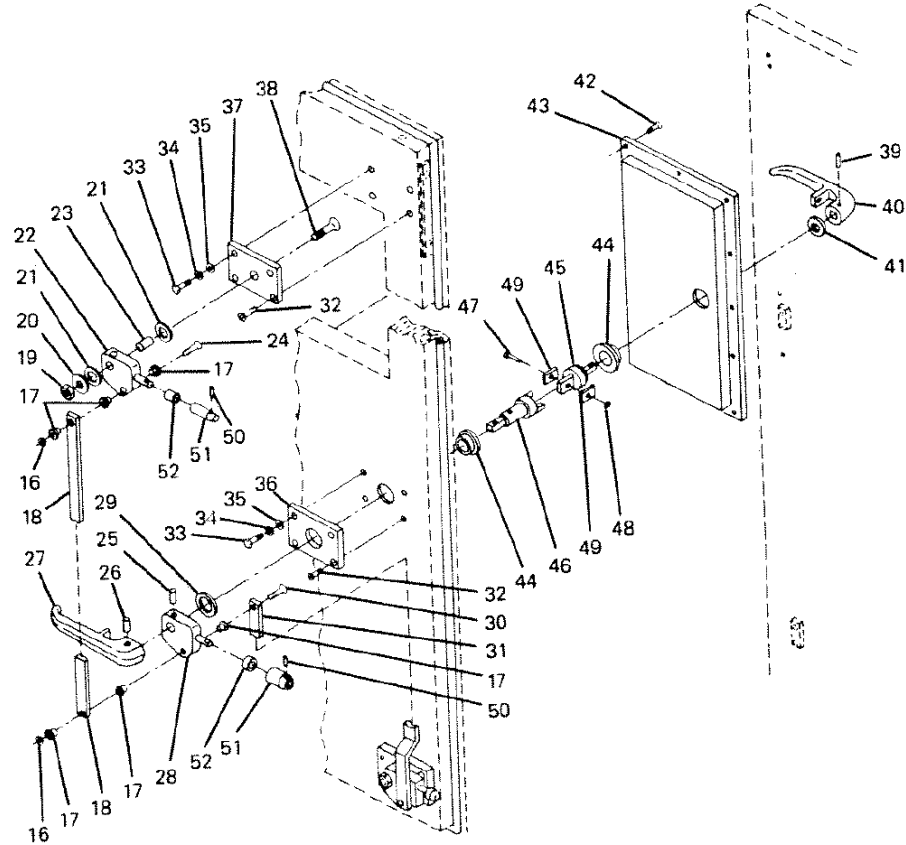

8. Position mounting plate (36) and install washers (35), lockwashers (34), bolts (33), and screws (32).
9. Position bottom rod (31), pin (30), flanged bearing (17), washer (29), latch arm (28), and inside handle (27) and install dowel pins (25 and 26).
10. Position flanged bearing (17), pin (24), washer (21), spacer (23), and latch arm (22) and install washers (20 and 21) and nut (19).
11. Position flanged bearing (17), top rod (18), and flanged bearing (17) and install retaining ring (16).
12. Seal. (Refer to para 4-36.)
13. Refinish. (Refer to para 4-37.)

4-17. (cont)

Door Vent

14. Position vent (15) in door and install rivets (14). (Refer to 4-26.)
15. Position rain strip (13) and retainer strip (12) and install rivets (11). (Refer to 4-26.)
16. Position retainer strips (10) and install rivets (9). (Refer to 4-26.)

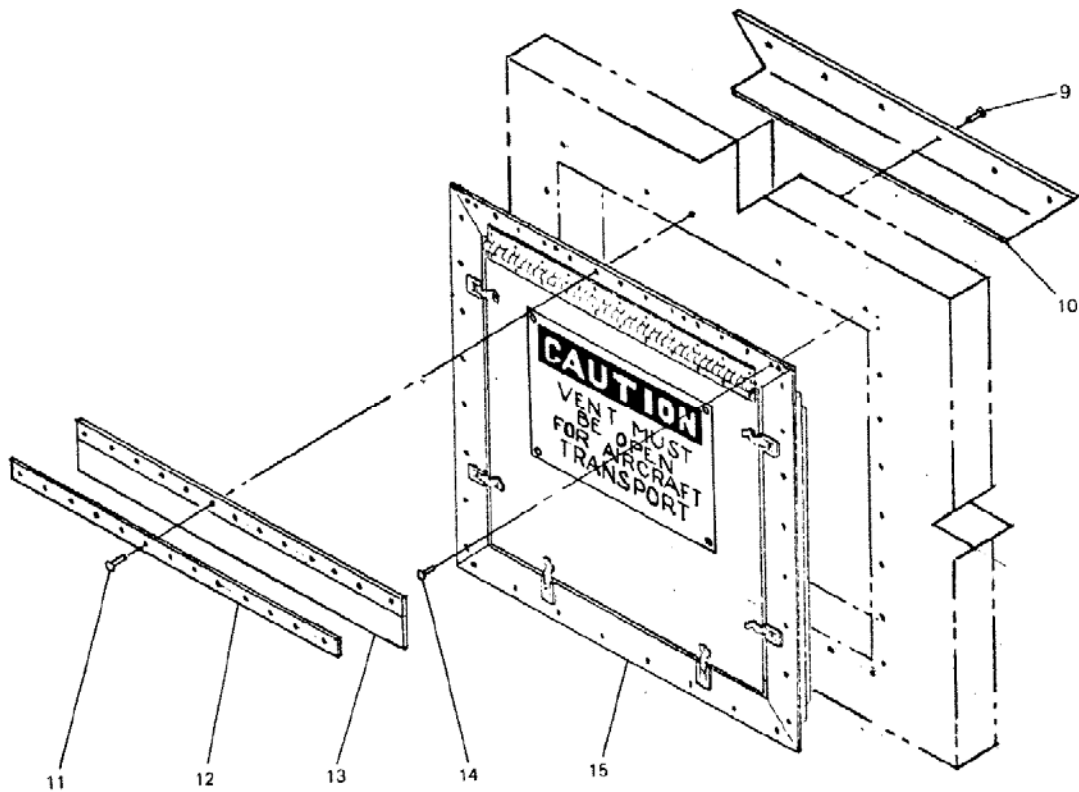

4-17. (cont)

Personnel Door

17. Secure each of four hinge base plates (8) to endwall with four washers (7), lockwashers (6), and bolts (5).
18. Position bracket (3) and install pin (2) and hairpin (1).

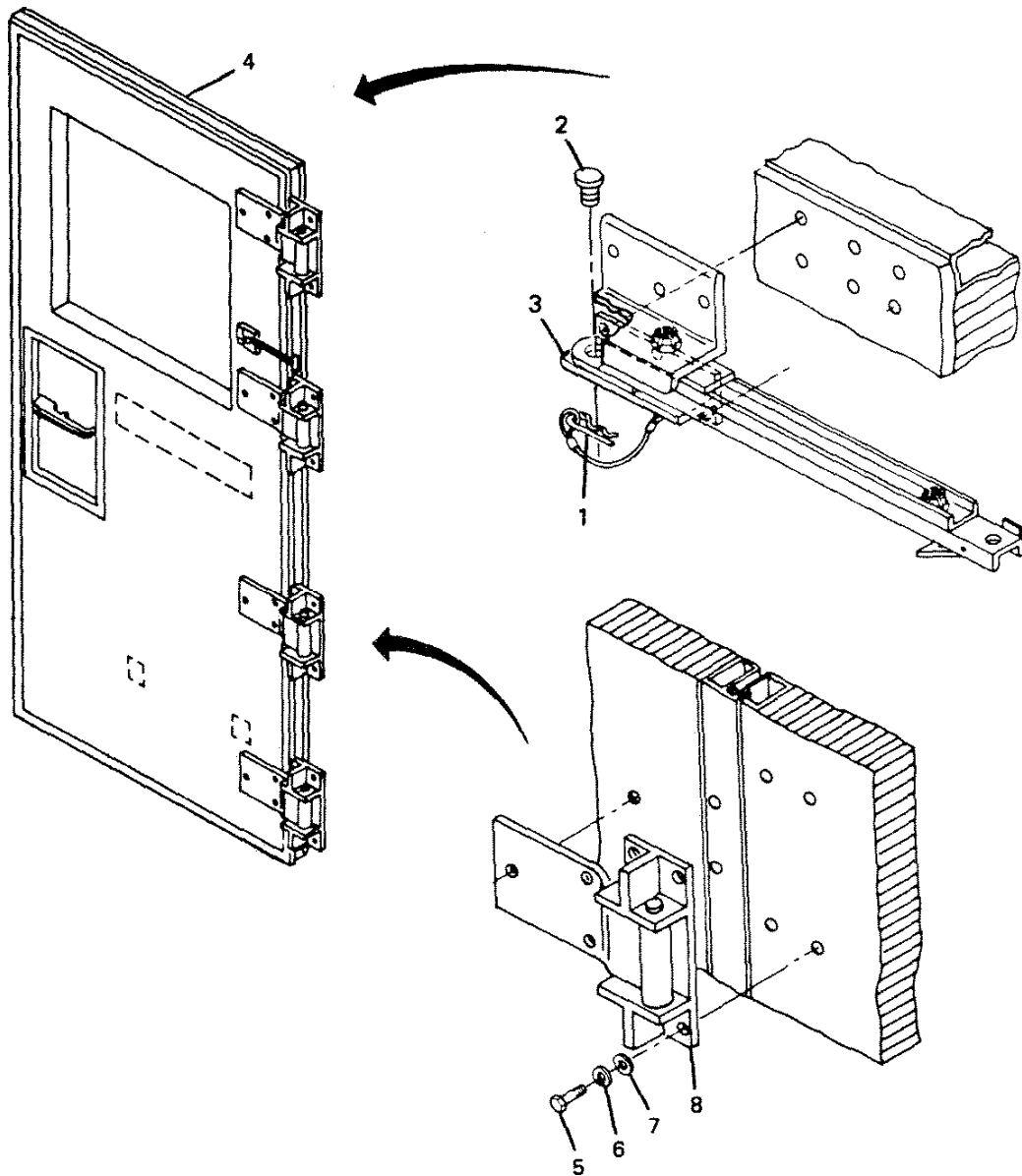

4-17. (cont)

ALIGNMENT

Door Vent

When installing door vent, make sure to center in door so there is an equal gap at both sides and at the top and bottom.

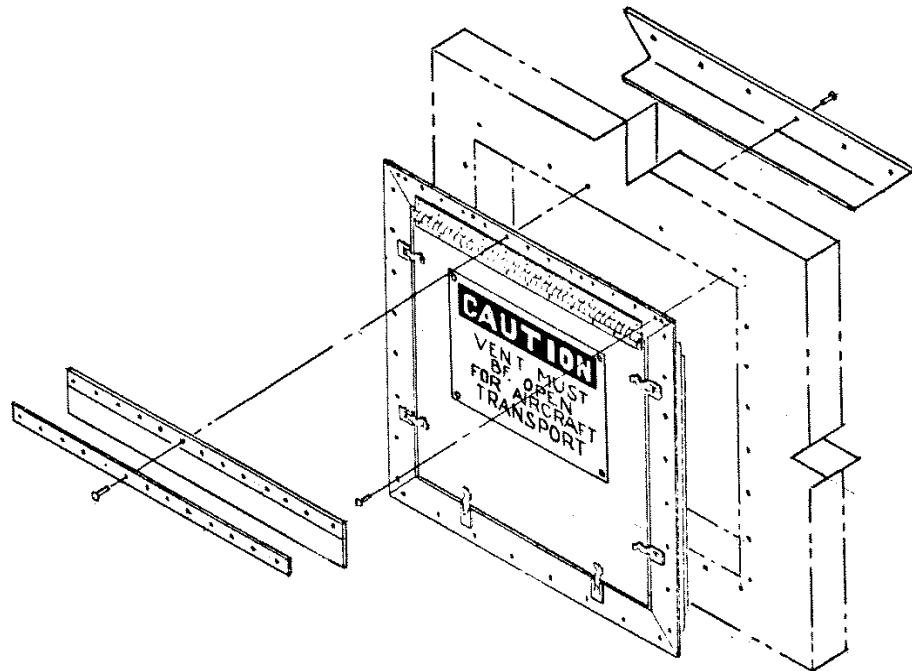

Personnel Door

Loosen hinge bolts and place wedges as required around periphery of door so there is an equal gap at both sides and at top and bottom.

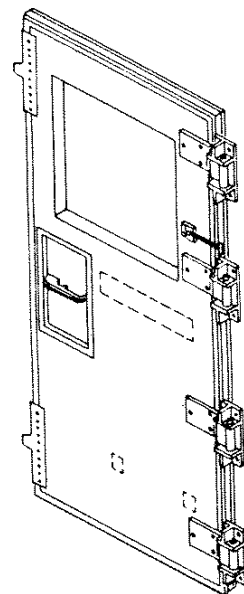

4-18. CONTAINER LIFT JACK ASSEMBLY

This task covers:

- | | |
|-------------------------|----------------|
| a. Disassembly | d. Lubrication |
| b. Cleaning, Inspection | e. Assembly |
| c. Repair | |

INITIAL SETUP

Standard tools

General mechanics tool kit
Grease gun

Materials

Grease, Item 12, Appendix E

DISASSEMBLY

1. Remove nut (1), spring plunger (2), pin (3), and handle (4).
 2. Remove pin (4) and separate handle (5) from support (6). Remove two O-rings (30) from handle (5).
 3. Remove grease fitting (7).
- NOTE
- Do not remove lanyard unless pins or cables are damaged.
4. Remove rivet (8) to remove lanyard (9) and safety pin (10).
 5. Remove screws (11), lockwashers (12), and spring tension clip (13).
 6. Remove cotter pin (14), washer (15), pin (16), and spacers (17) to remove base (18) from basic jack.
 7. Remove inside tube (19) and jack screw (20) from outside tube (21).
 8. Remove bearing (22).
 9. Drive pin (23) out through access hole and remove jack screw (20) from inside tube (19).
 10. Remove screws (24), retainer (25), and rotating insert (26).
 11. Remove screws (27), lockwashers (28), and handle (29). Remove O-rings (30).

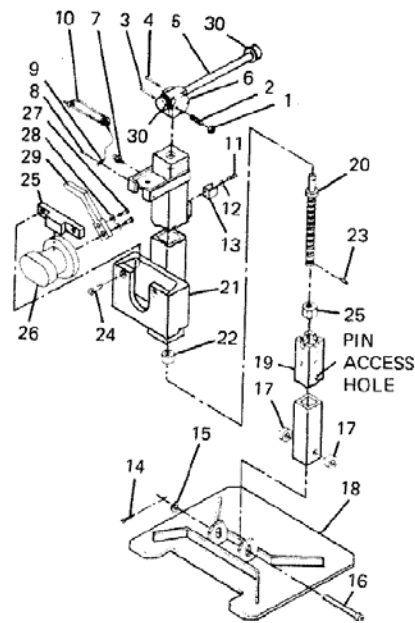

4-18. (cont)

CLEANING, INSPECTION

1. Wipe jack assembly and component surfaces.
2. Inspect mounting surfaces for corrosion and damage.
3. Inspect for and replace if necessary.
 - a. Missing or damaged components
 - b. Corrosion or paint damage.

REPAIR

Corrosion or paint damage. (Refer to 4-37.)

LUBRICATION

Lubricate jack assembly with grease.

ASSEMBLY

1. Position handle (29) on rotating insert (26) and install lockwashers (28) and screws (27). Install O-rings (30).
2. Position rotating insert (26) in outside tube (21) and secure retainer (25) with screws (24).
3. Install jack screw (20) in inside tube (19).
4. Align hole in jack screw (20) with access hole in inside tube (19) and install pin (23).
5. Pack bearing (22) with grease and place on jack screw (20).
6. Install inside tube (19) in outside tube (21).
7. Position handle (5) in support (6) and on jack screw (19) with holes in handle yoke and jack screw aligned. Install pins (3 and 4).

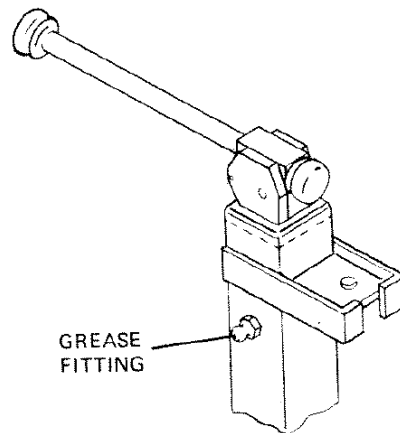
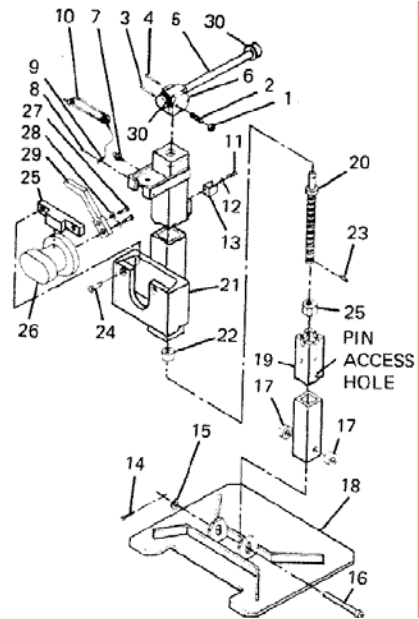

4-18. (cont)

8. Install spring plunger (2) in handle yoke and secure with nut (1). Adjust nut to control handle movement.
9. Position basic jack on base (18) with spacers (17) and secure with pin (16), washer (15), and new cotter pin (14).
10. Install grease fitting (7) and lubricate jack with grease.

4-19. FRONT ENDWALL PANEL

This task covers:

- | | |
|-------------------------|-----------------|
| a. Removal | d. Repair |
| b. Disassembly | e. Assembly |
| c. Cleaning, Inspection | f. Installation |

INITIAL SETUP

Special Tools

Hand blind riveter, Appendix B, Item 2

Personnel – 4

1 Electrician

Materials

Adhesive, Item 2, Appendix E

Standard Tools

General mechanics tool kit
Electrical Tool Kit

REMOVAL

Front Endwall Panel

1. Set main circuit breaker to OFF position.
2. Disconnect service entry power at power entry panel and remove panel. (Refer to para 4-8, panel wiring.)
3. Remove door activated blackout switch and associated wiring. (Refer to 4-14.)
4. Remove area light assembly. (Refer to 3-4.)
5. Remove circuit breaker box. (Refer to para 4-7.)

4-19. (cont)

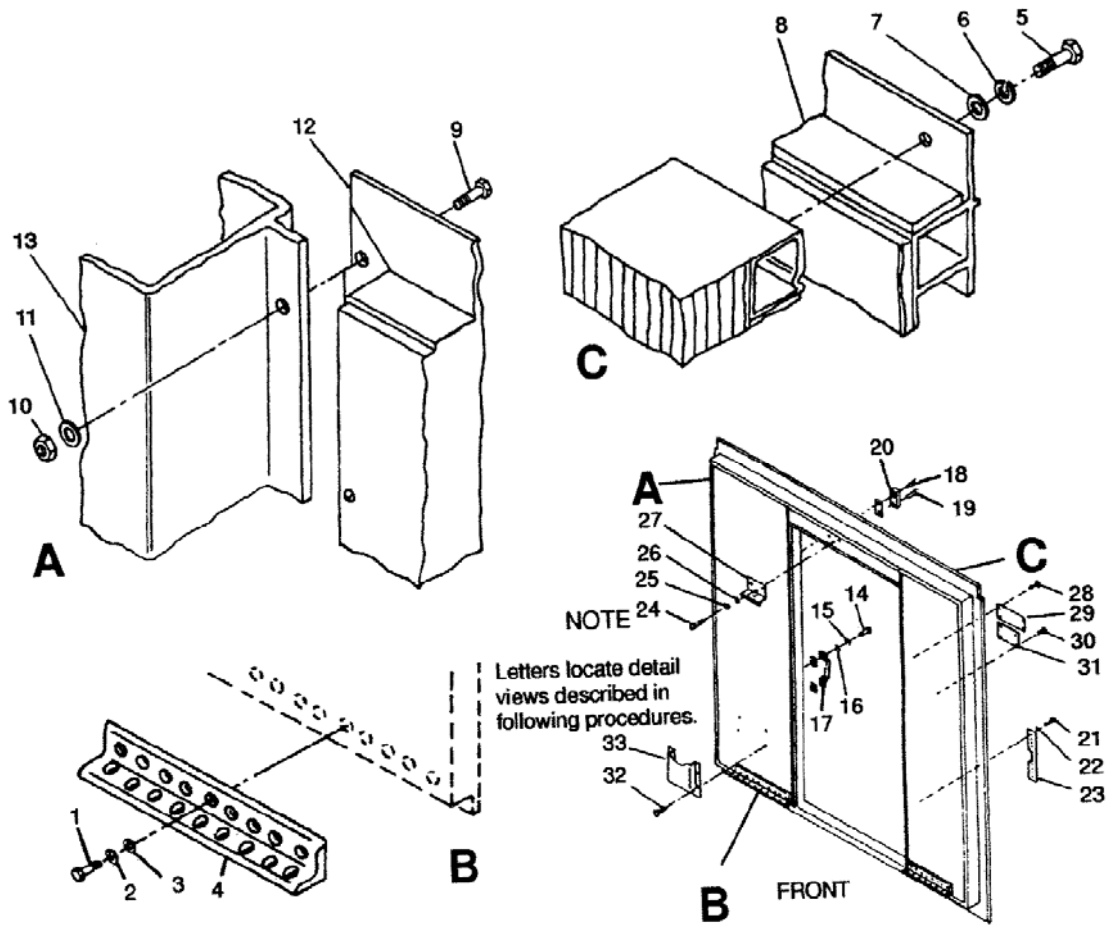

6. Remove screws (1), lockwashers (2), and washers (3) securing reinforcement angles (4) to endwall.
7. Remove bolts (5), lockwashers (6) and washers (7) securing endwall (8) to roof and floor.
8. Remove bolts (9), nuts (10), and washers (11) securing endwall (12) to corner posts (13).
9. Remove screws (14), lockwashers (15), and washers (16) and remove ice break (17).

4-19. (cont)

10. Remove screws (18 and 19) and remove keepers (20).
11. Remove screws (21), lockwashers (22), and shear plates (23).
12. Remove screws (24), lockwashers (25), washers (26), and door assembly mounting bracket (27).
13. Remove rivets (28) and identification plate (29).
14. Remove rivets (30) and paint plate (31).
15. Remove rivets (32) and manual holder (33).
16. Support endwall and remove by using a putty knife (or similar tool) to break bond between endwall and roof, floor, and corner posts.

Level Assembly

17. Drill out six rivets (34) and remove each of two level assemblies (35). (Refer to 4-26.)

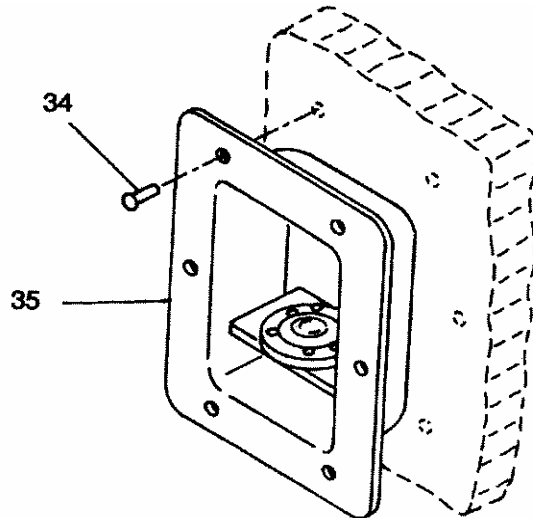

Folding Step

18. Remove two screws (36) and lockwashers (37) and remove each of five folding steps (38).

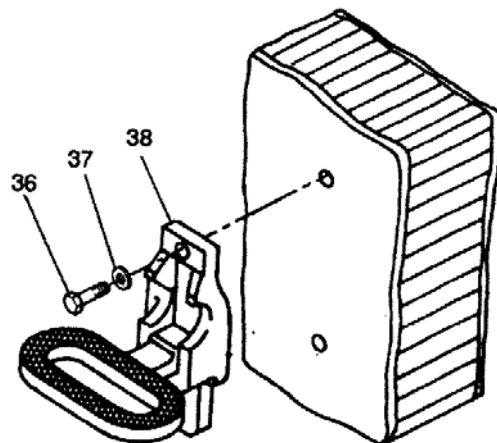

4-19. (cont)

DISASSEMBLY

Front Endwall Panel

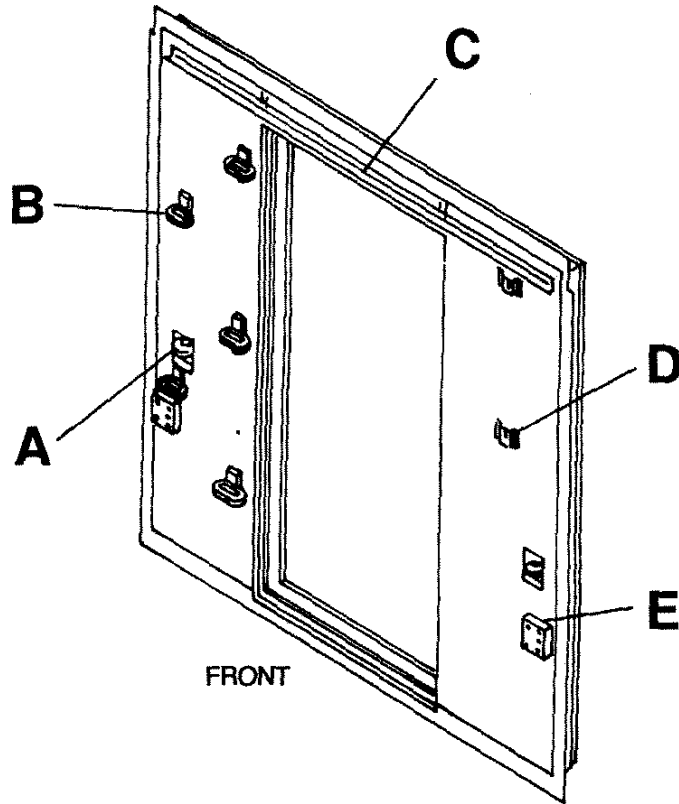

1. Drill out rivets (1) and remove level (2). (Refer to 4-26.)
2. Remove screws (3) and lockwashers (4) and remove folding step (5).

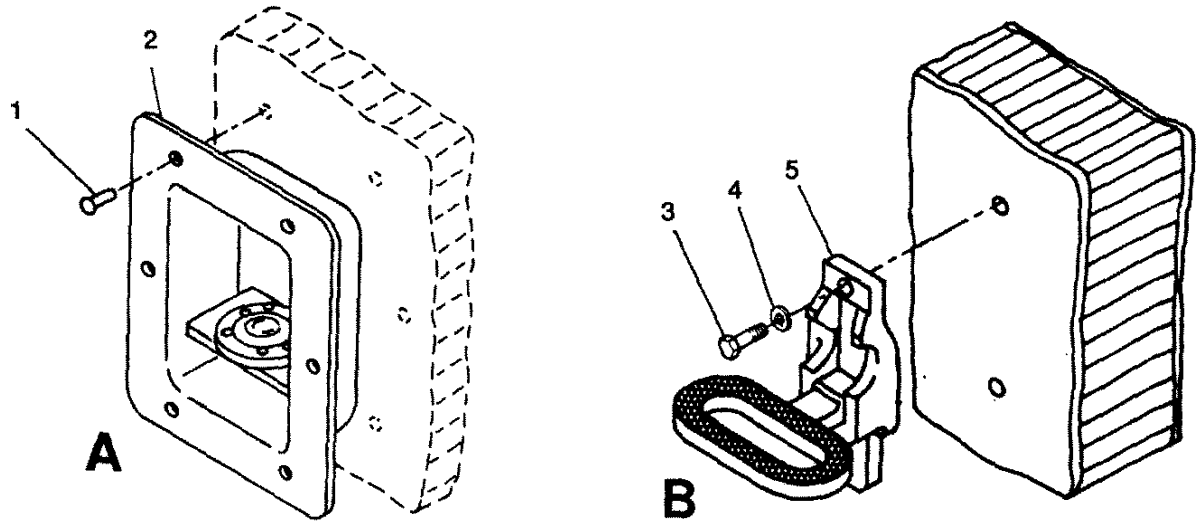

4-19. (cont)

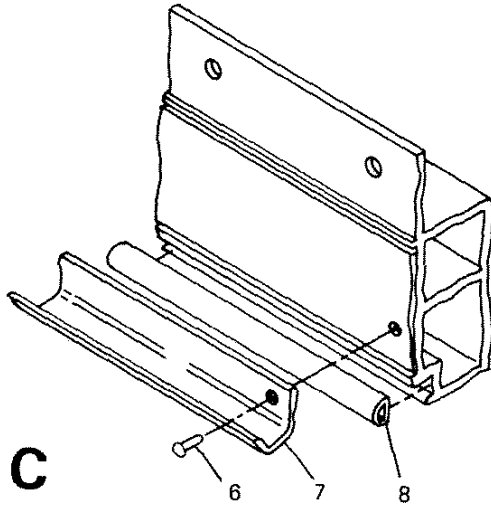

C

3. Drill out rivets (6) and remove drip strip (7). (Refer to 4-26.)
4. Strip seal (8) away from door opening.
5. Drill out rivets (9) and remove light bracket (10). (Refer to 4-26.)
6. Remove screws (11) and lockwashers (12) and remove upper mobilizer fitting (13).

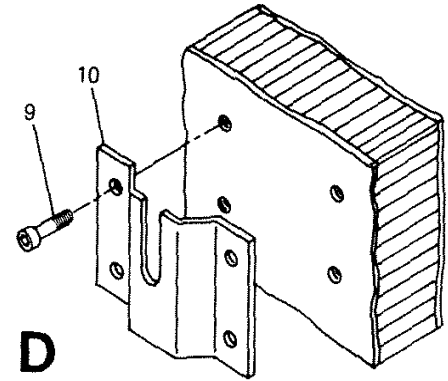

D

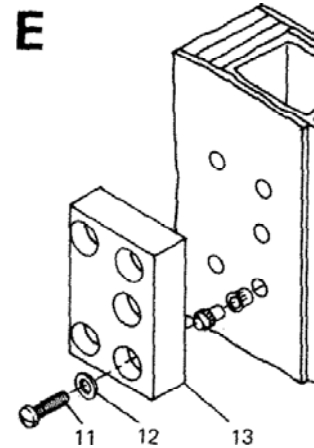

E

Level Assembly

7. Remove screws (14), lockwashers (15), and setscrews (16) and remove level indicator (17) from level bracket (19).
8. Drill out rivets (18) and remove level bracket (19) from level pan (20). (Refer to 4-26.)

CLEANING, INSPECTION

1. Wipe panel and component surfaces.
2. Inspect mounting surfaces for corrosion and damage.
3. Inspect for and replace if necessary:
 - a. Missing or damaged components
 - b. Corrosion or paint damage.

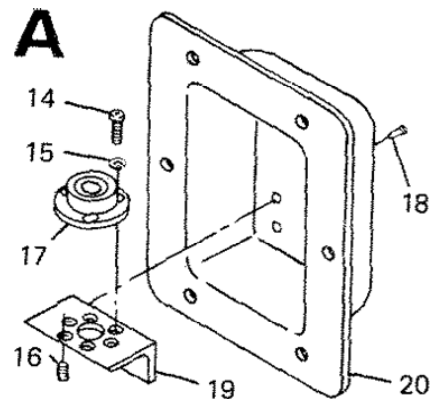

A

4-19. (cont)

REPAIR

1. Panel skin damage. (Refer to paragraphs 4-25 through 4-36.)
2. Corrosion or paint damage. (Refer to 4-37.)

ASSEMBLY

Level Assembly

1. Secure level bracket (19) to level pan (20) by installing rivets (18). (Refer to 4-26.)
2. Position level indicator (17) on level bracket and install set-screws (16), lockwashers (15), and screws (14).

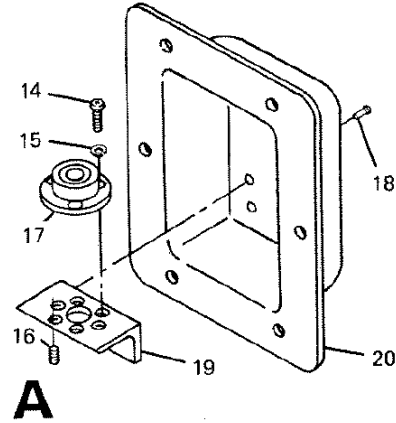

Front Endwall Panel

3. Position mobilizer fitting (13) and install lockwashers (12) and screws (11).

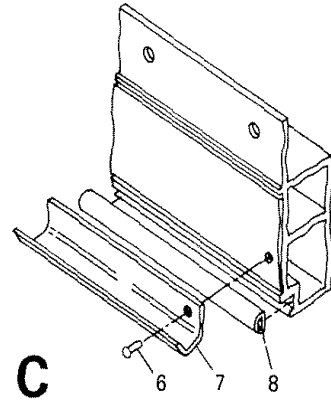
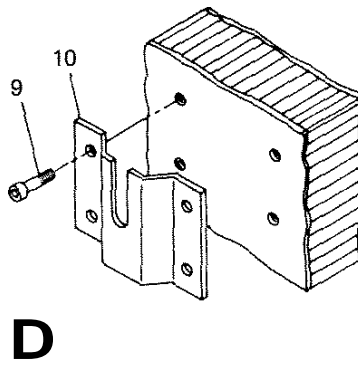
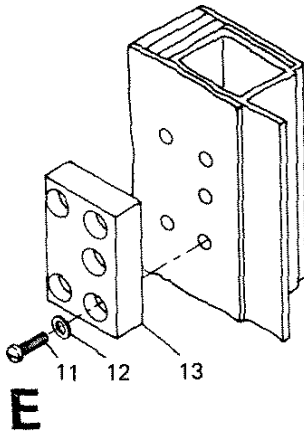

4. Position light bracket (10) and install rivets (9). (Refer to 4-26.)
5. Bond seal (8) in place with adhesive. (Refer to 4-34.)
6. Position drip strip (7) and install rivets (6). (Refer to 4-26.)

4-19. (cont)

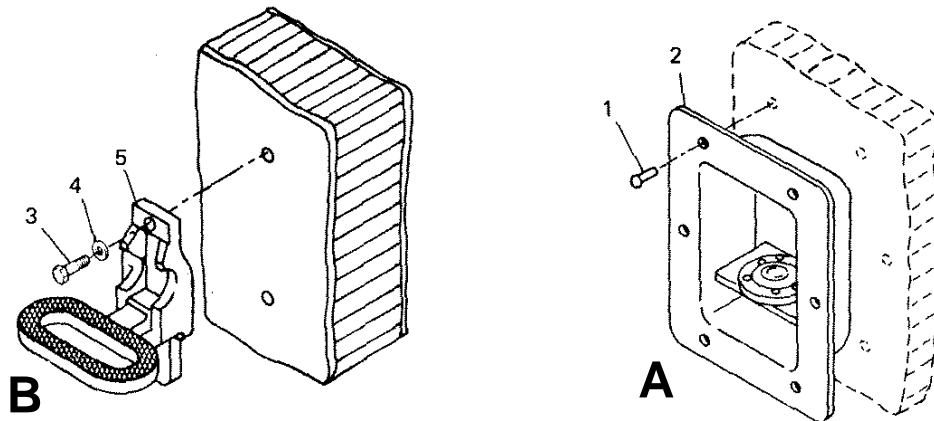

7. Position folding step (5) and install lockwashers (4) and screws (3).
8. Position level (2) and install rivets (1). (Refer to 4-26.)

INSTALLATION

Folding Step

1. Position each of five folding steps (38) against panel and install two lockwashers (37) and screws (36).

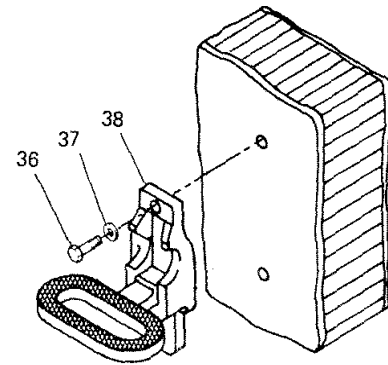

Level Assembly

2. Secure each of two level assemblies (35) by installing six rivets (34). (Refer to 4-26.)

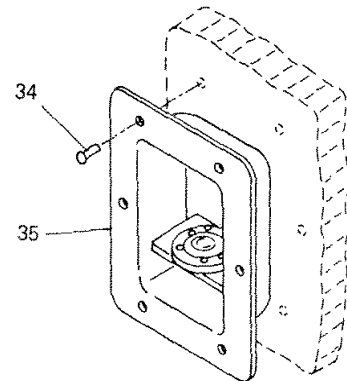

NOTE

Level assemblies must be calibrated after assembly of shelter is complete. Use a four foot level or other suitable tool and adjust three setscrews on level to calibrate.

Front Endwall Panel

3. From outside shelter, position endwall on floor and push inward until endwall is against corner posts mating surfaces.
4. Align endwall mounting holes with mounting holes and inserts in corner posts, roof, reinforcement angles, and floor.

4-19. (cont)

NOTE

Align mounting holes at endwall corners and insert bolts. Check that remaining holes and inserts are aligned and free from obstructions.

5. Install rivets (32) securing manual holder (33). (Refer to 4-26.)
6. Install rivets (30) securing paint plate (31). (Refer to 4-26.)
7. Install rivets (28) securing identification plate (29). (Refer to 4-26.)
8. Install screws (24), lockwashers (25), and washers (26) securing door assembly mounting bracket (27).
9. Install screws (21) and lockwashers (22) securing shear plates (23).
10. Install screws (18 and 19) securing keepers (20) to endwall.
11. Install screws (14), lockwashers (15), and washers (16) securing ice break (17) to endwall.

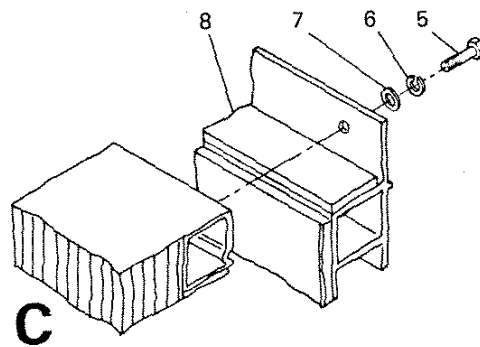
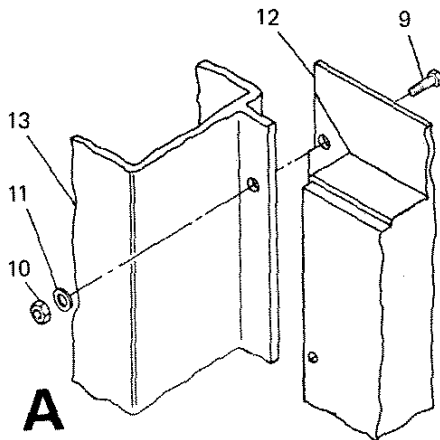
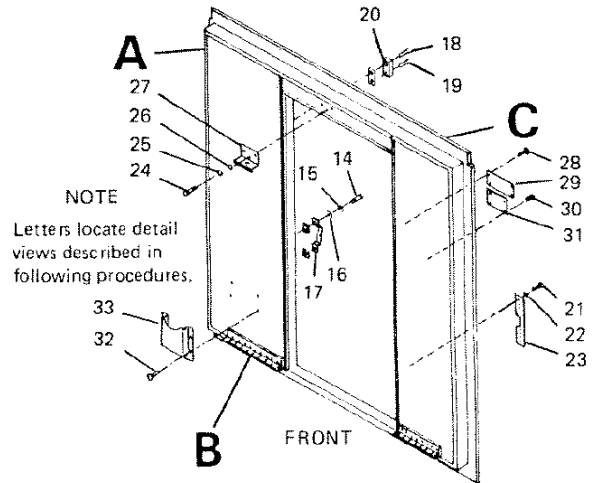

12. Install bolts (9), washers (11), and nuts (10) securing endwall (12) to corner posts (13).
13. Install washers (7), lockwashers (6), and bolts (5) securing endwall (8) to roof and floor.

4-19. (cont)

14. Install washers (3), lockwashers (2), and screws (1) securing reinforcement angles (4) to endwall.
15. Install area light assembly. (Refer to para 3-4.)
16. Install door activated blackout switch and associated wiring. (Refer to para 4-14.)
17. Install power entry panel. (Refer to para 4-8.)
18. Install circuit breaker box. (Refer to para 4-7.)
19. Connect services entry power and set main circuit breaker to ON position.

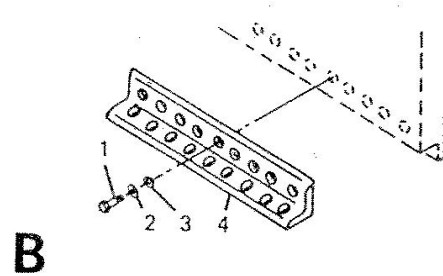

4-20. REAR ENDWALL PANEL

This task covers:

- | | |
|-------------------------|-----------------|
| a. Removal | d. Repair |
| b. Disassembly | e. Assembly |
| c. Cleaning, Inspection | f. Installation |

INITIAL SETUP

Special Tools

Hand blind riveter, Appendix 8, Item 2

Standard Tools

General mechanics tool kit

Materials

Adhesive, Item 2, Appendix E

Personnel - 4

Removal

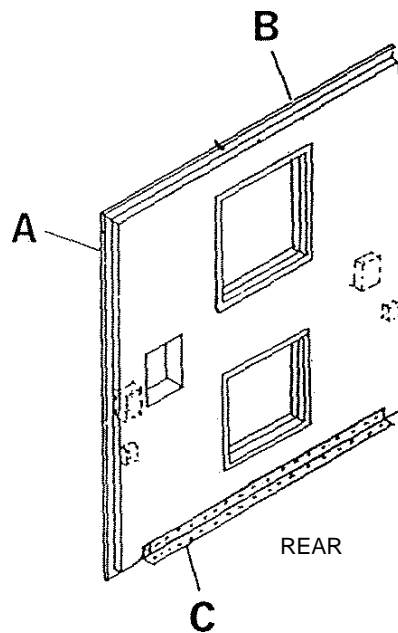

NOTE
Letter locate detail
views described in
following procedures.

4-20. (cont)

1. Remove screw (1), securing two corner enclosures (2), to sidewall panel and endwall (6).
2. Remove bolts (3), nuts (4) and washers (5) securing endwall (6) to corner posts (7).
3. Remove bolts (8), lockwashers (9), and washers (10) securing endwall (6) to floor and roof.
4. Remove screws (11), lockwashers (12), and washers (13) securing reinforcement angle (14) to endwall (6) and floor.
5. Drill out rivets (15), remove safety plate (16) from endwall (6).

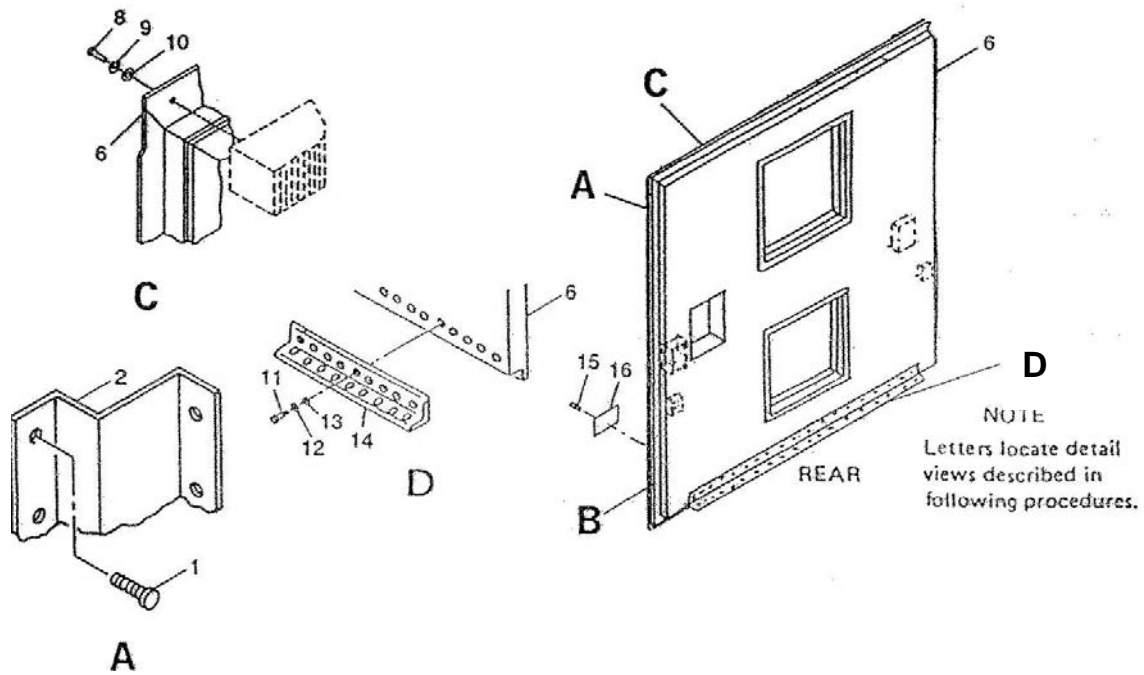
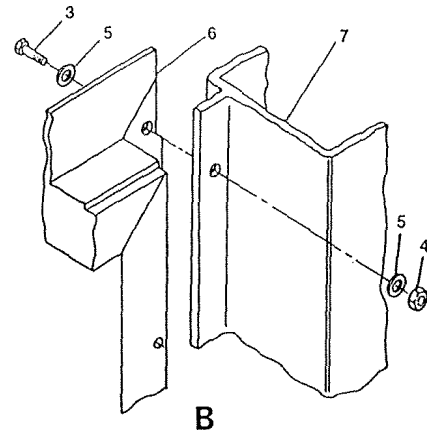

6. Support endwall (6), cut through adhesive sealant, and remove by using a putty knife (or similar tool) to break bond between endwall and roof, floor, and corner posts.

4-20. (cont)

DISASSEMBLY

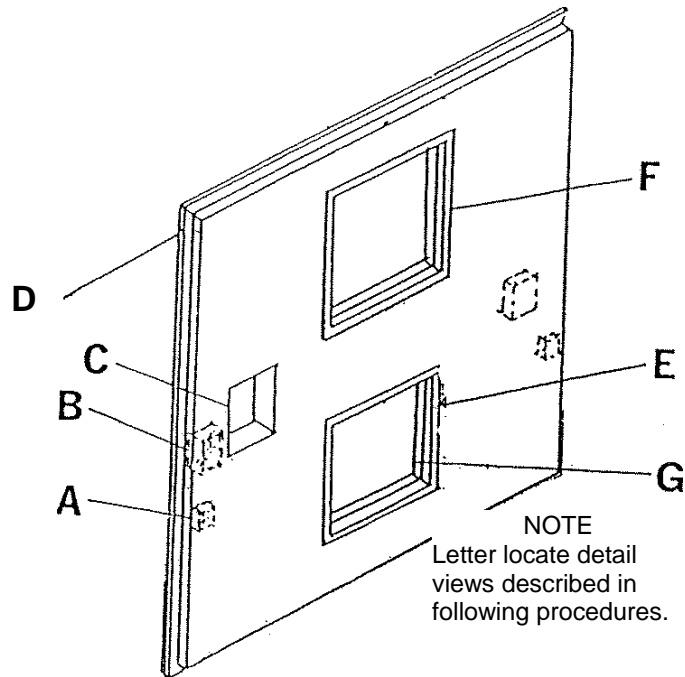

Rear Endwall Panel

1. Remove screws (1) and lockwashers (2) and remove upper mobilizer fittings (3).
2. Drill out rivets (4) and remove level pan (5). (Refer to para 4-26.)
- 2.1 Drill out rivets (6) and remove power panel ECU (7). (Refer to para 4-15.)

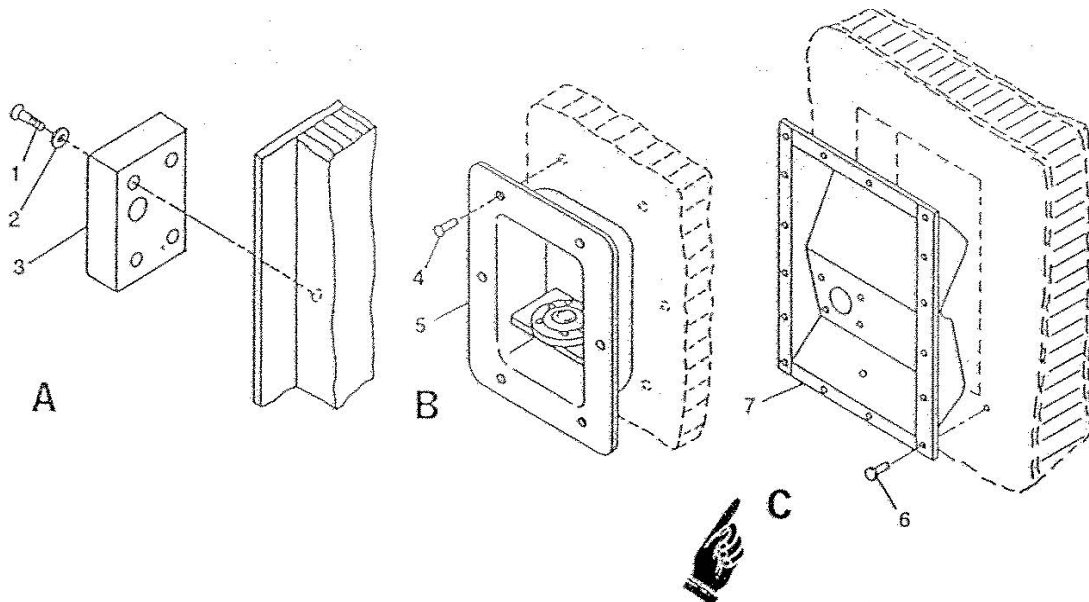

4-20. (cont)

3. Strip seal (8) away from opening.

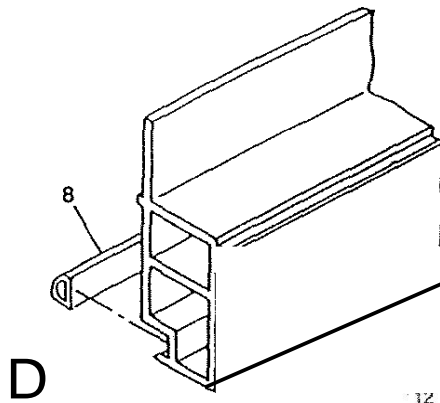

ECU Intake Panel

4. Remove captive screws (9) and two washers (10) at each of four locations on ECU intake panel (11).
5. Remove weather seal (12) from ECU intake panel (11). (Refer to para 4-34.)
6. Drill out rivets (13) and remove vent cover grill (14) from ECU intake panel (11). (Refer to para 4.26.)

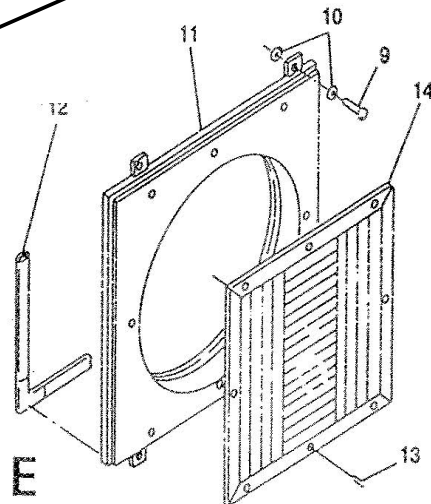

ECU Return Panel

7. Remove captive screw (15) and two washers (16) at each of four locations on ECU return panel (17).
8. Remove weather seal (18) from ECU return panel (17). (Refer to para 4-34.)

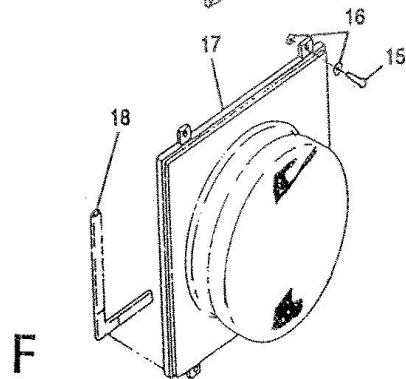

4-20. (cont)

Closeout Panel

9. Remove captive screw (19) and two washers (20) at each of four locations on ECU intake and return closeout panels (21).
10. Remove weather seals (22) from ECU intake and return closeout panels (21). (Refer to para 4-34.)

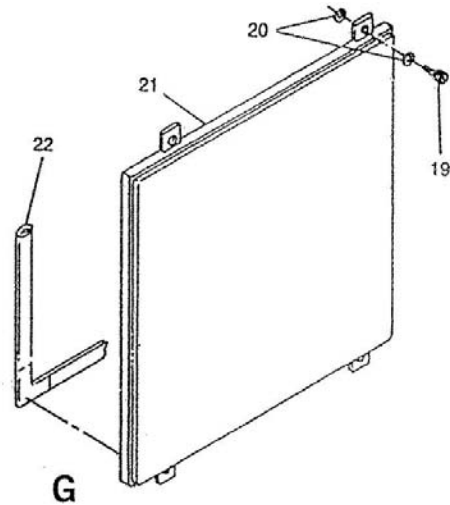

CLEANING, INSPECTION

1. Clean panel and component surfaces.
2. Inspect mounting surfaces for corrosion and damage.
3. Inspect for and replace if necessary:
 - a. Missing or damaged components.
 - b. Corrosion or paint damage.

REPAIR

1. Panel skin damage. (Refer to para 4-25 through 4-36.)
2. Corrosion or paint damage. (Refer to para 4-37.)

ASSEMBLY

Closeout Panel

1. Attach weather seals (22) to ECU intake and return closeout panels (21). (Refer to para 4-34.)
2. Using installation tool, assemble two washers (20) and captive screw (19) at each of four locations on ECU intake and return closeout panels (21).

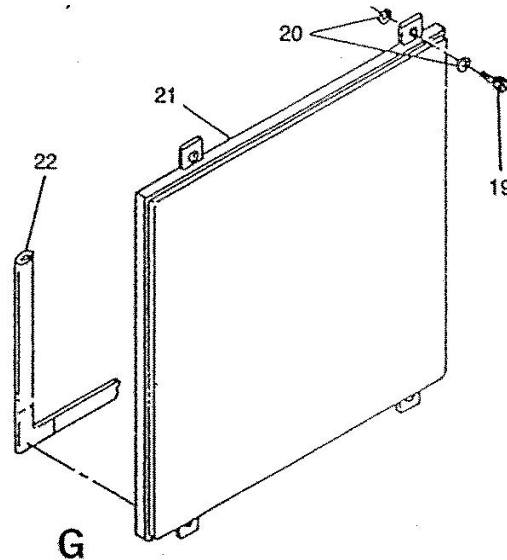

4-20. (cont)

ECU Return Panel

3. Attach weather seal (18) to ECU return panel (17) with adhesive. (Refer to para 4-34.)
4. Using installation tool, assemble two washers (16) and captive screw (15) at each of four locations on ECU return panel (17).

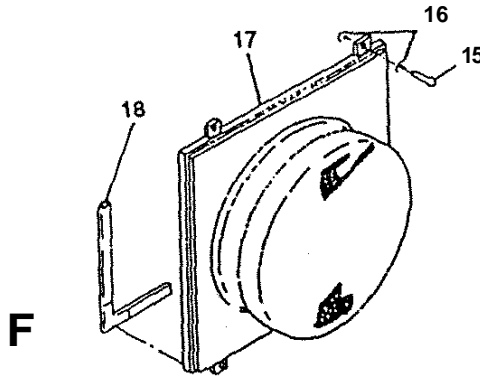

ECU Intake Panel

5. Position vent cover grill (14) on ECU intake panel (11) and secure with rivets (13). (Refer to para 4-26.)
6. Attach weather seal (12) to ECU intake panel (11) with adhesive. (Refer to para 4-34.)
7. Using installation tool, assemble two washers (10) and captive screw (9) at each of four locations on ECU intake panel (11).

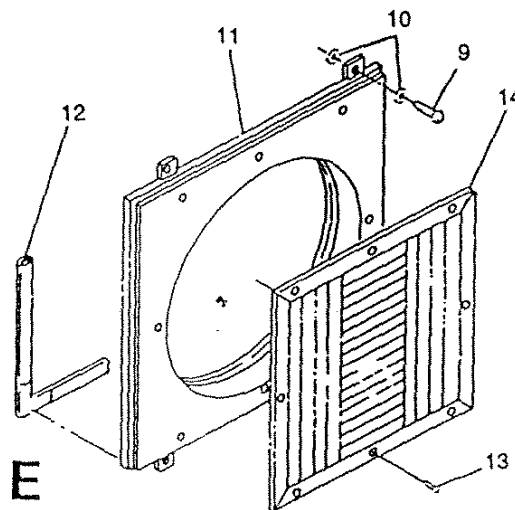

4-20. (cont)

Rear Endwall Panel

8. Bond seal (8) in place with adhesive. (Refer to para 4-34.)

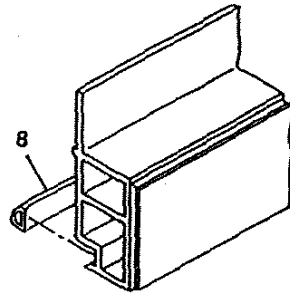

D

9. Position upper mobilizer fitting (3) and install lockwashers (2) and screws (1).
- 9.1. Replace power panel ECU (7) (refer to 4-26) and install rivets (6).
10. Position level (5) and install rivets (4). (Refer to para 4-26.)

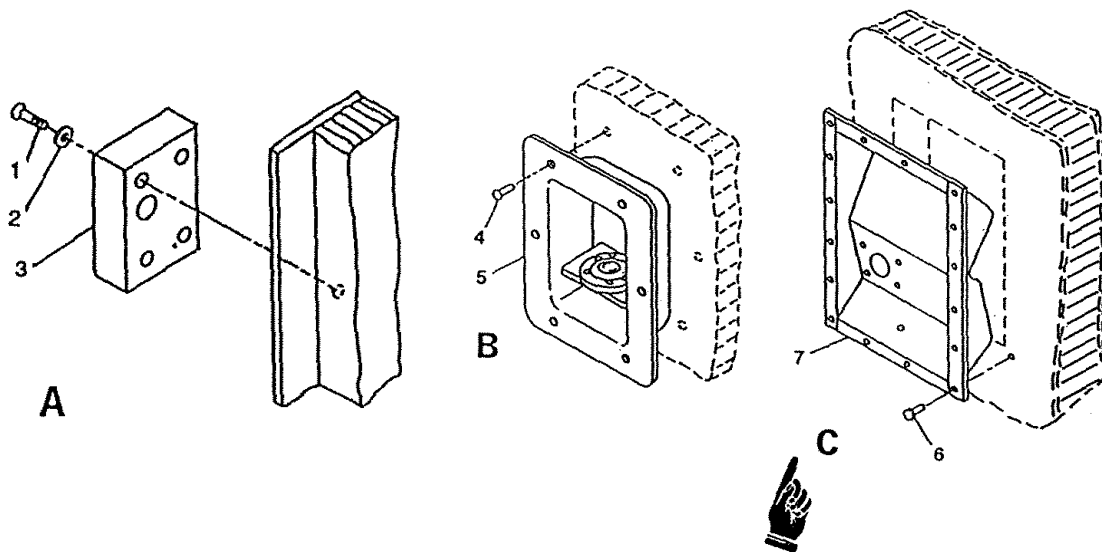

A

B

C

4-20. (cont)

INSTALLATION

1. Install rivets (15), and secure safety approval plate (16) to endwall (6). (Refer to para 4-26.)
2. Apply adhesive before positioning endwall panel.
3. From outside shelter, position endwall on floor and push inward until endwall is against corner posts mating surfaces.
4. Align endwall mounting holes with mounting holes and inserts in corner posts, roof, and floor.

NOTE

Align mounting holes at endwall corners and install bolts. Check that remaining holes and inserts are aligned and free from obstructions.

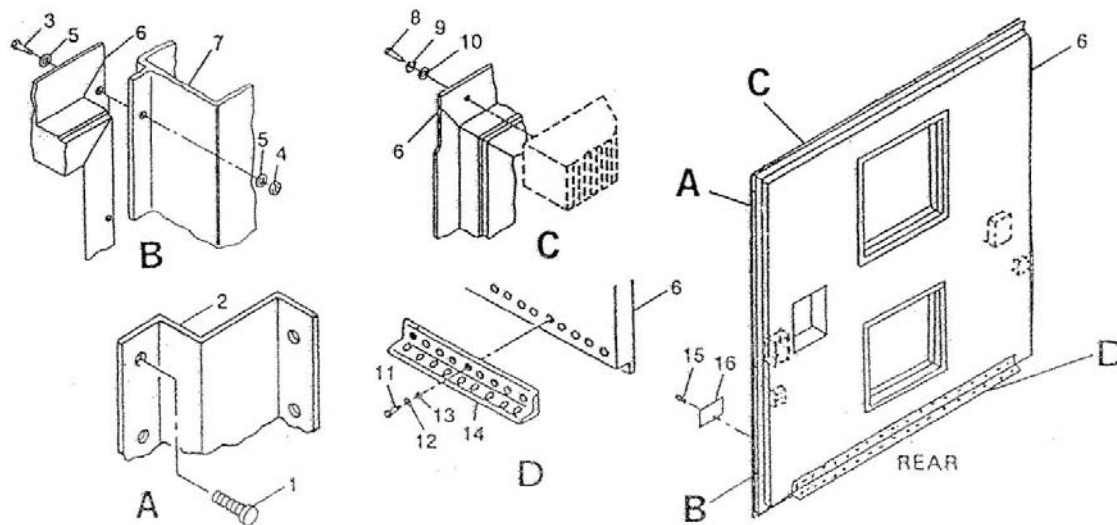

5. Install bolts (3), washers (5), and nuts (4) securing endwall (6) to corner posts (7).
6. Install screws (1), securing two corner enclosures (2), to sidewall panel and endwall (6).
7. Install bolts (8), lockwashers (9), and washers (10) securing endwall (6) to floor and roof.
8. Install bolts (11), lockwashers (12), washers (13) securing reinforcement angle to floor and endwall (6).
9. Install personnel door in accordance with paragraph 4-17.
10. Calibrate level after shelter is assembled using four-foot level and three setscrews to properly calibrate.

4-21. SIDEWALL PANEL

This task covers.

- | | |
|-------------------------|-----------------|
| a. Removal | d. Repair |
| b. Disassembly | e. Assembly |
| c. Cleaning, Inspection | f. Installation |
-

INITIAL SETUP

Standard Tools

- Hand blind riveter, Appendix B, Item 2
- Installation tool, Appendix B, Item 3

Materials

- Adhesive, Item 3, Appendix E
- Sealing Compound, Item 19, Appendix E
- Solvent, Item 20, Appendix E

Standard Tools

- General mechanics tool kit
- Electrical tool kit

Personnel - 4

- 1 Electrician

Equipment Condition

- Electrical components removed (Para 4-12)
-

REMOVAL

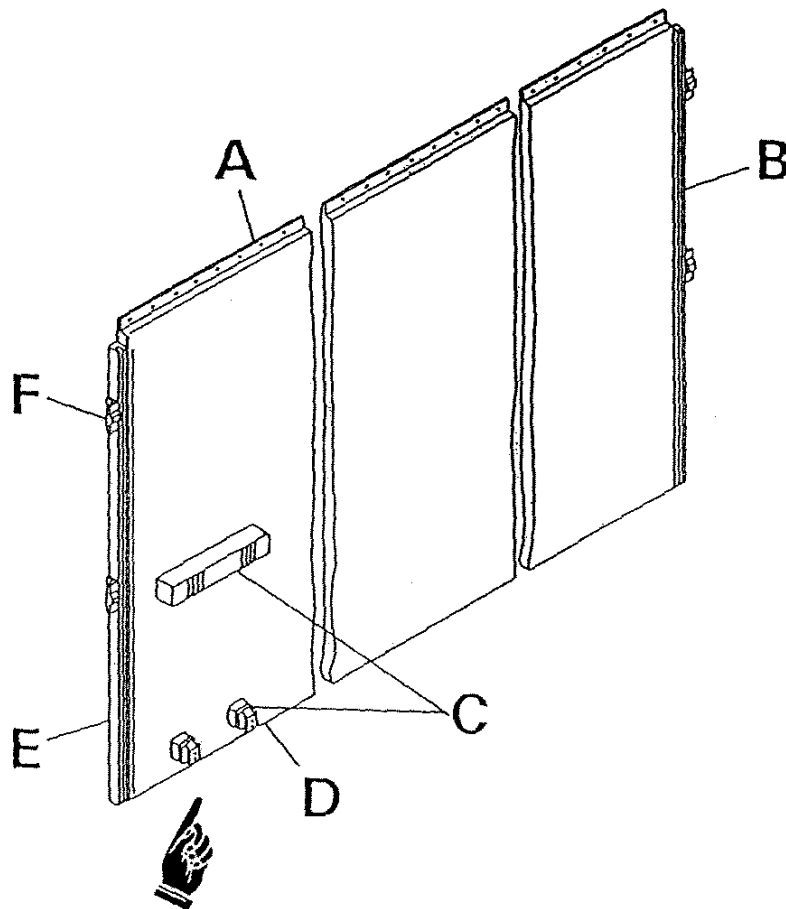

4-21. (cont)

1. Remove screws (1) securing two corner enclosures (2) to sidewall panel (6).

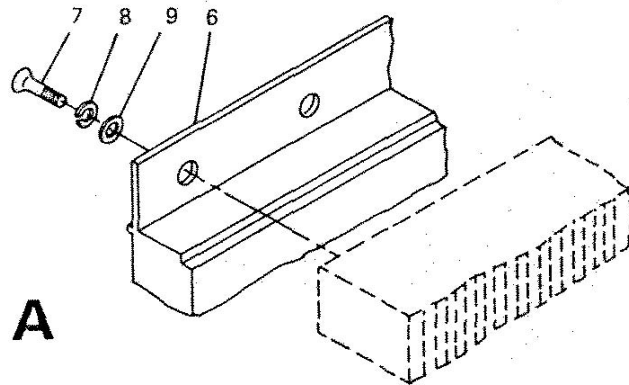
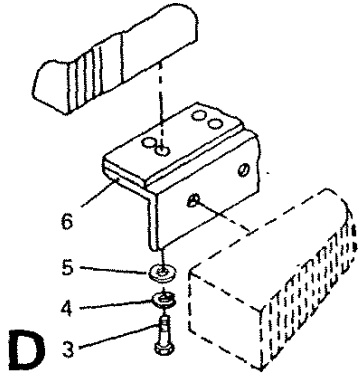
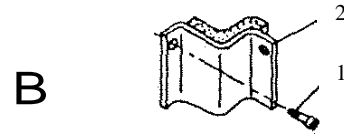

2. Remove bolts (3), lockwashers (4), and washers (5) securing sidewall panel (6) to floor.
3. Remove bolts (7), lockwashers (8), and washers (9) securing sidewall panel (6) to roof.

WARNING

Methylethylketone is flammable and toxic and shall be used in a well-ventilated area away from sparks or open flame. Gloves should be worn when used.

4. Apply solvent to sealed interface areas of sidewall panel and mating surfaces.
5. Block or support sidewall panel from outside shelter and use putty knife to break sealant.
6. Push from inside shelter and remove sidewall panel.

4-21 (cont)

DISASSEMBLY

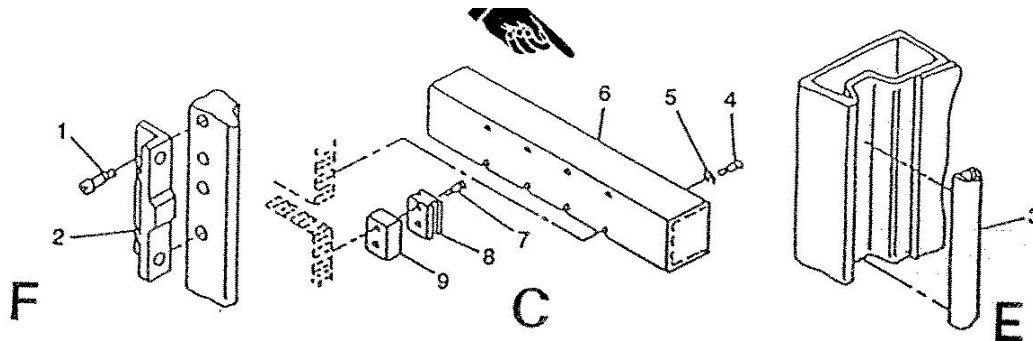

1. Drill out rivets (1) and remove shear plate (2). (Refer to para 4-26.)
2. Strip seal (3) from sidewall panel.

Jack Storage Bracket (Left Sidewall Only)

3. Remove screws (4) and lockwashers (5) securing jack storage bracket (6) to sidewall panel.
4. Remove screws (7) securing jack support bracket (8) and spacer (9) to sidewall panel.

CLEANING, INSPECTION

1. Wipe sidewall panel and component surfaces.
2. Inspect mounting surfaces for corrosion and damage.
3. Inspect for and replace if necessary:
 - a. Missing or damaged components
 - b. Corrosion or paint damage.

REPAIR

1. Panel skin damage (Refer to para 4-25 through 4-36.)
2. Corrosion or paint damage. (Refer to para 4-37.)

ASSEMBLY

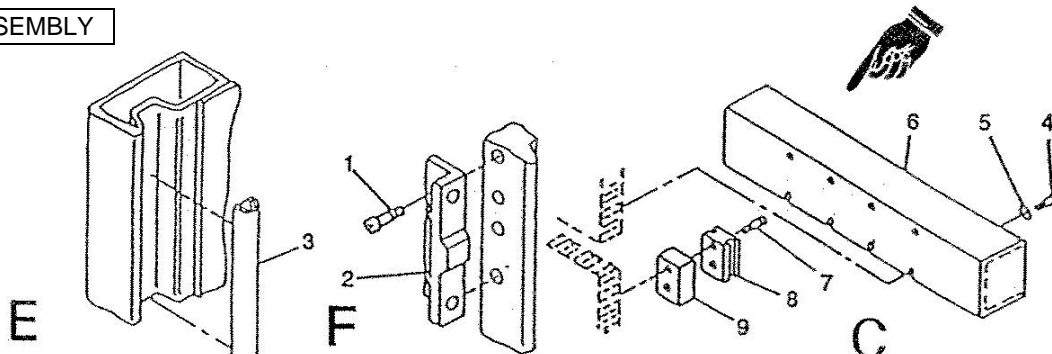

1. Coat seal (3) with adhesive and install. (Refer to para 4-34.)
2. Position shear plate (2) and install rivets (1). (Refer to para 4-26.)

4-21. (cont)

Jack Storage Bracket (Left Sidewall Only)

3. Position spacer (9), jack support bracket (8) and install screws (7).
4. Position jack storage bracket (6) and install lockwashers (5) and screws (4).

INSTALLATION

1. Apply sealing compound to interface areas of sidewall panel (6) and mating surfaces.
2. From outside shelter, position sidewall panel (6) on floor and push inward until sidewall is against mating surfaces.
3. Align sidewall panel mounting holes with inserts in roof and floor.

NOTE

Align mounting holes at sidewall panel corners and install bolts. Check that remaining holes and inserts are aligned and free from obstructions.

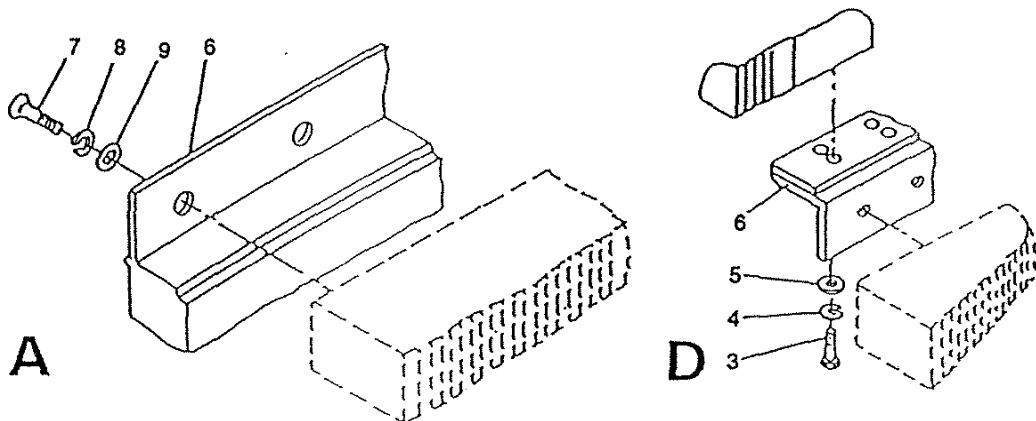

4. Install washers (9), lockwashers (8), and bolts (7) securing sidewall panel (6) to roof.
5. Install washers (5), lockwashers (4) and bolts (3) securing sidewall panel (6) to floor.
6. Align corner enclosures (2) with anchors in sidewall panel (6) and install screws (1).

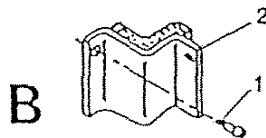

4-22. ROOF PANEL

This task covers.

- | | |
|-------------------------|-------------|
| a. Disassembly | c. Repair |
| b. Cleaning, Inspection | d. Assembly |

INITIAL SETUP

Standard Tools
General mechanics tool kit

Equipment Condition
ECU panels removed from roof panel
Electrical components and raceway removed
(para 4-16.1)

Personnel - 1

DISASSEMBLY

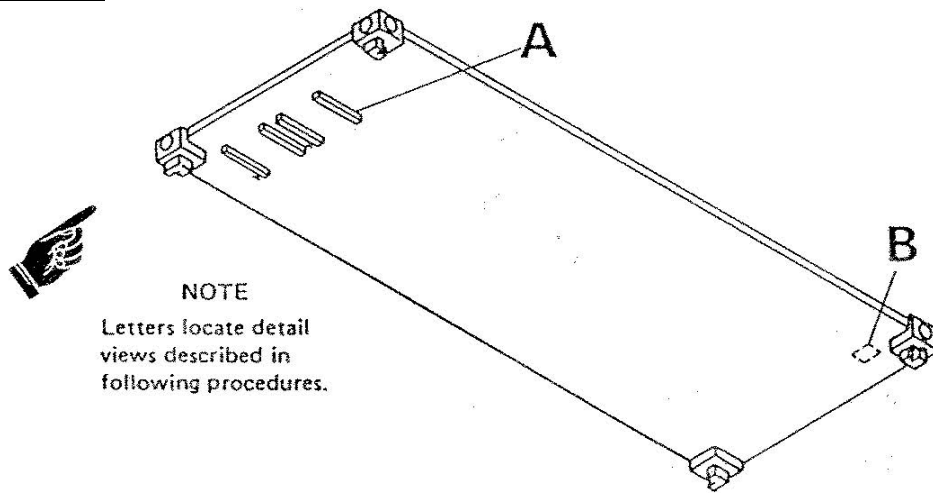

Stowage Brackets

1. Remove screws (1), lockwashers (2), and washers (3) and remove stowage brackets (4 and 5).

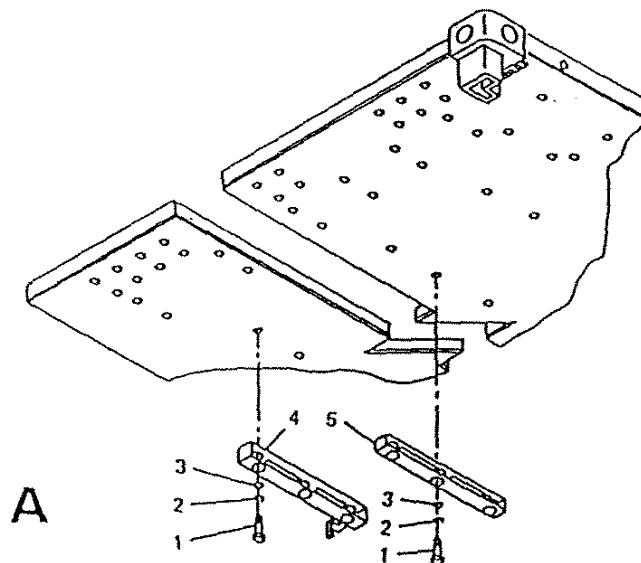

4-22. (cont)

Folding Handle

2. Remove screws (6), lockwashers (7), and washers (8) and remove handle (9).

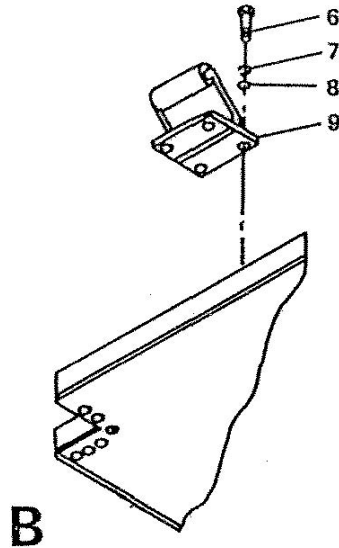

CLEANING, INSPECTION

1. Wipe panel and component surfaces.
2. Inspect mounting surfaces for corrosion and damage.
3. Inspect for and replace if necessary:
 - a. Missing or damaged components.
 - b. Corrosion or paint damage.

REPAIR

1. Panel skin damage (Refer to paragraphs 4-25 through 4-36.)
2. Corrosion or paint damage. (Refer to 4-37.)

ASSEMBLY

Folding Handle

1. Position handle (9) on top of fixed roof and install washers (8), lockwashers (7), and screws (6).

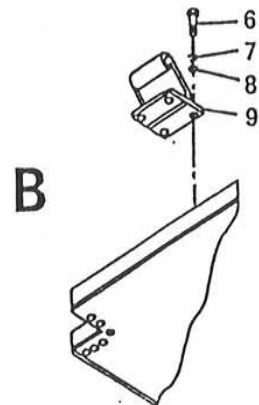

4-22. (cont)

Stowage Brackets

2. Position stowage brackets (4 and 5) and install washers (3), lockwashers (2), and screws (1).

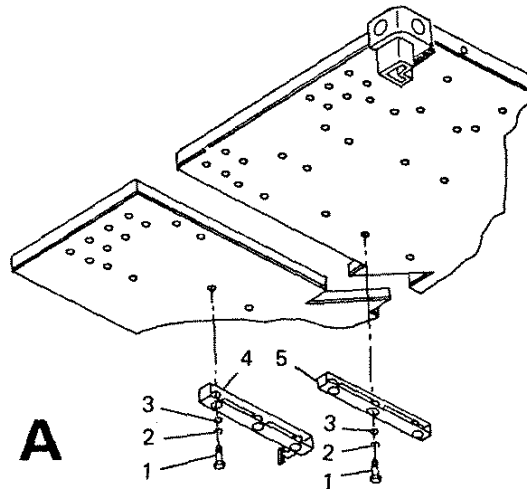

4-23. FLOOR PANEL/BASE FRAME

This task covers:

- a. Disassembly
- b. Cleaning, Inspection
- c. Assembly

INITIAL SETUP

Standard Tools

General mechanics tool kit
 Personnel - 4

Materials

Adhesive, Item 3, Appendix E
 Sealing Compound, Item 19,
 Appendix E

DISASSEMBLY

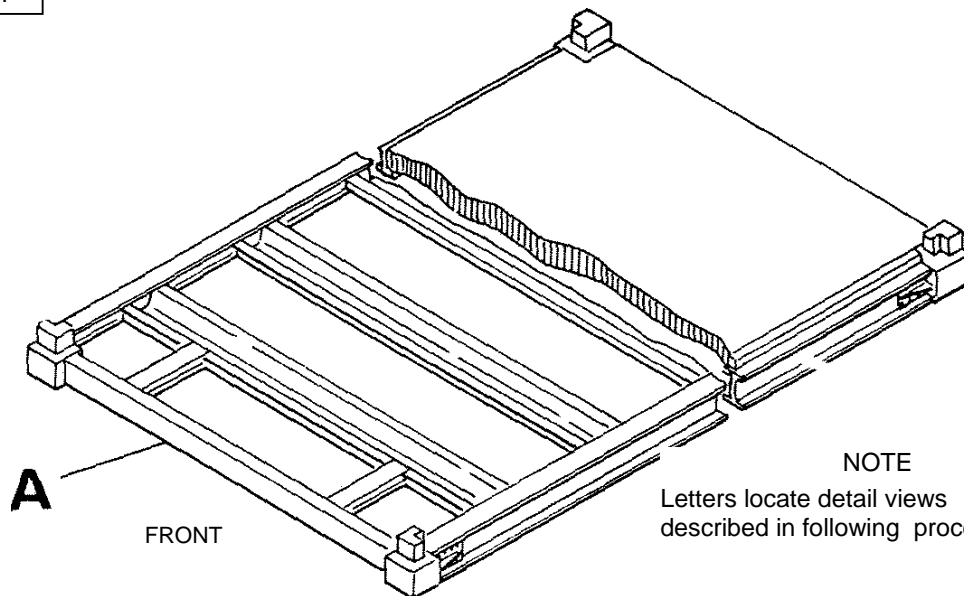

NOTE
 Letters locate detail views described in following procedures.

4-23. (cont)

1. Remove bolts (1), screws (2), nuts (3), lockwashers (4), and washers (5), securing lower mobilizer fitting (6) and spacer (7) to support channel (8).
2. Remove bolts (9), nuts (10), lockwashers (11), and washers (12) securing brackets (13) to base frame (14).

CLEANING, INSPECTION

1. Clean panel and component surfaces.
2. Inspect mounting surfaces for corrosion and damage.
3. Inspect for and replace if necessary:
 - a. Missing or damaged components.
 - b. Corrosion or paint damage.

REPAIR

1. Panel skin damage (Refer to paragraphs 4-25 through 4-36.)
2. Corrosion or paint damage (Refer to 4-37.)

ASSEMBLY

1. Position brackets (13) on base frame (14) and install bolts (9), washers (12), lockwashers (11), and nuts (10).
2. Position spacer (7) and lower mobilizer fitting (6) on base support channel (8) and install screws (2), bolts (1), washers (5), lockwashers (4), and nuts (3).

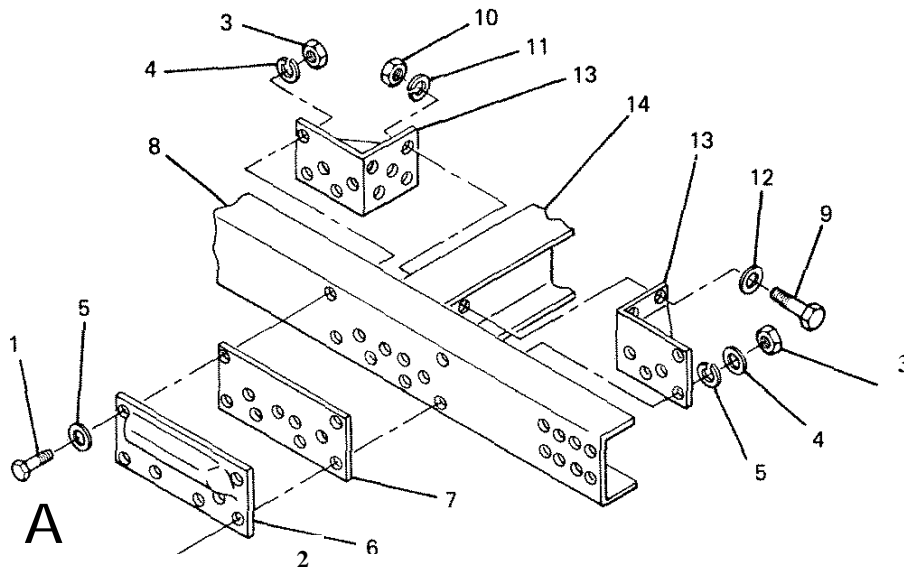

4-24. EQUIPMENT CONTAINER

This task covers:

- | | |
|-------------------------|-----------------|
| a. Removal | c. Repair |
| b. Cleaning, Inspection | d. Installation |

INITIAL SETUP

Special tools

Hand blind riveter, Appendix B, Item 2
 Personnel - 2

Standard Tools

General mechanics tool kit

REMOVAL

1. Unscrew two tie-down rings (1) at the end of two strap assemblies (2) from floor panel.
2. Lift equipment container (3) from floor and remove from shelter.
3. Remove rivets (4) and chest handles (5). (Refer to 4-26.)
4. Remove rivets (6) and hinges (7). (Refer to 4-26.)
5. Remove rivets (8) and safety hasp (9). (Refer to 4-26.)
6. Remove rivets (10) and draw pull catches (11). (Refer to 4-26.)

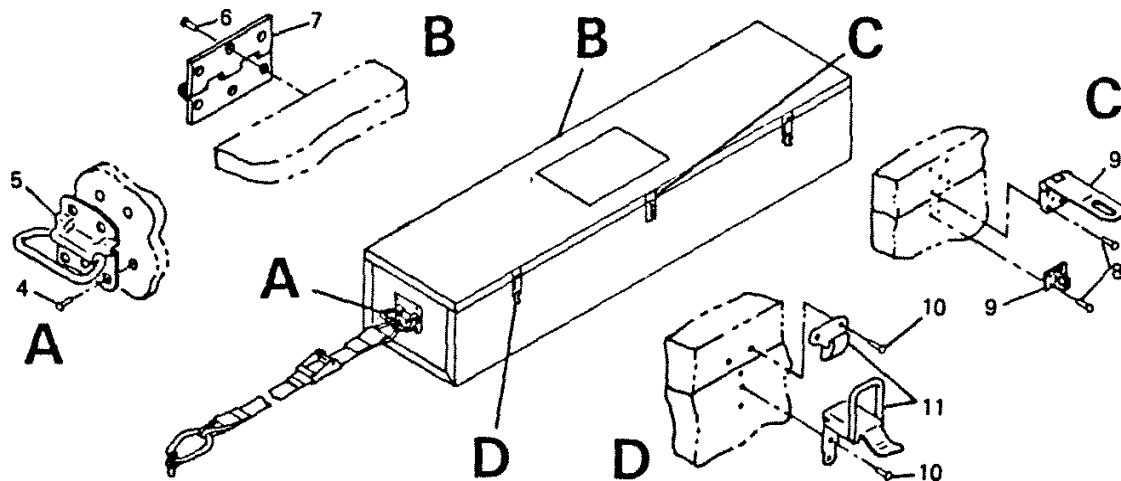

CLEANING, INSPECTION

1. Wipe equipment container and component surfaces.
2. Inspect mounting surfaces for corrosion and damage.

4-24. (cont)

3. Inspect for and replace if necessary:
 - a. Missing or damaged components.
 - b. Corrosion or paint damage.

REPAIR

1. Corrosion or paint damage (Refer to 4-37.)
2. Replace damaged tie-down ring or strap assembly.

INSTALLATION

1. Position draw pull catches (11) on equipment container (3) and secure with rivets (10). (Refer to 4-26.)
2. Position safety hasp (9) on equipment container (3) and secure with rivets (8). (Refer to 4-26.)
3. Position hinges (7) on equipment container (3) and secure with rivets (6). (Refer to 4-26.)
4. Position chest handles (5) on equipment container (3) and secure with rivets (4). (Refer to 4-26.)
5. Position equipment container (3) on floor panel.
6. Install two tie-down rings (1) at the end of two strap assemblies (2) in holes in floor panel to secure equipment container (3) to floor.

Section V. COMMON REPAIRS

The procedures in paragraph 4-25 through 4-37 are common repairs and apply for all panel surfaces.

4-25. DRYING WATER-SOAKED AREAS IN PANELS

a. Care shall be taken to prevent water from entering panel core material, since it is very difficult to remove. When damage occurs, the punctured panel skin shall be temporarily protected with masking tape (Appendix E, Item 22) to prevent entry of water until repair can be made. If water has been allowed to enter panel, the core material shall be dried prior to skin repair.

b. Position heat lamps (Appendix B, Item 15) around damaged area. Adjust lamps so that panel surface temperature does not exceed 200°F (93.3°C).

4-25. (cont)

- c. Allow heat lamps to remain in position until core material surrounding damaged area is thoroughly dry.

NOTE

Drying time will vary and is determined by experience and amount of moisture in panel. Core material will feel hard and brittle when dry.

- d. After core material is thoroughly dried, repair panel in accordance with the applicable repair task.

4-26. BLIND RIVET REMOVAL AND INSTALLATION

- a. Remove blind rivets as follows:

WARNING

Wear safety goggles for eye protection from flying metal chips.

- (1) Select drill bit the same diameter as installed blind rivet.

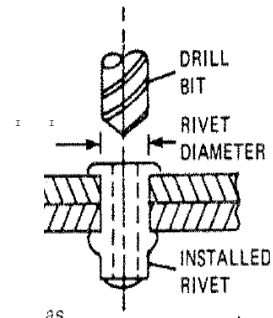

- (2) Install selected drill bit in hand drill chuck.

- (3) Hold drill perpendicular to the surface to prevent enlargement or damage to existing hole.

- (4) Drill through center of rivet just deep enough to sever rivet head from shank.

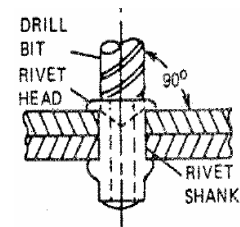

- (5) Remove remainder of rivet with a pin punch.

- (6) Deburr rivet hole.

- b. Install blind rivets as follows:

- (1) Select proper diameter and length of blind rivet (Items 13-16, Appendix E).

- (2) Select appropriate nose piece for hand blind riveter and install nose piece.

- (3) Wet rivet with sealant (Item 18, Appendix E) and insert rivet in hole.

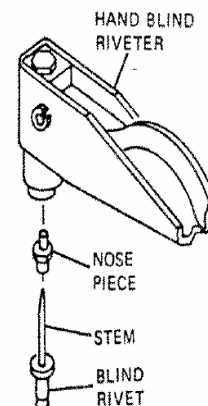

4-26. (cont)

- (4) Holding hand blind riveter at right angle to work, install on blind rivet stem.
- (5) Push against work with just enough force to firmly seat rivet and prevent part separation.
- (6) Actuate and pull rivet until stem breaks.
- (7) Trim broken stem flush with rivet head.
- (8) Firmly press on installed rivet to check tightness of installation.
- (9) Remove and replace in accordance with procedure if installation is unacceptable.

c. Blind bolt removal.

- (1) The blind bolt (BP-T & B100-T) can be removed by using the proper size blind bolt removal tool kit and any portable electric drill with a rated speed of no more than 1250 RPM.
- (2) The tools in this kit are illustrated on page 4-94, and are tabulated on page 4-94.
- (3) The fastener removal consists of four operations:
 - (a) Operation I - Drill pin. (See page 4-96)
 - (b) Operation II - Knock out drilled pin and remove upper portion of pin and lock collar. (See page 4-97)
 - (c) Operation III - Counterbore sleeve. (See page 4-98)
 - (d) Operation IV - Knock out counterbored sleeve and remove head of sleeve. (See page 4-99)

NOTE

The illustration of the operations for removal show a countersunk blind bolt. The removal of a protruding head blind bolt is the same. A micro-limit tool is used with the counterbore cutter in Operation III to control the depth of the cut.

4-26. (cont)

TABLE I				
VISUAL INSPECTION TABLE				
Rivet Dia.	Collar Position "A" max.	Lock Position		Minimum Blind Head Diameter
		"B" max. above	"C" max. below	
3/16"	.022"	.012"	.012"	.238"
1/4"	.029"	.015"	.015"	.315"

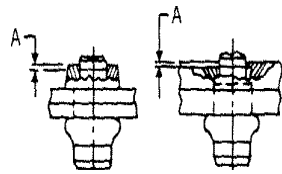

INSPECTION OF LOCKING COLLAR POSITION

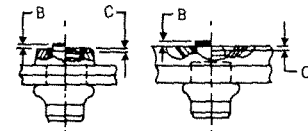

INSPECTION OF PIN POSITION

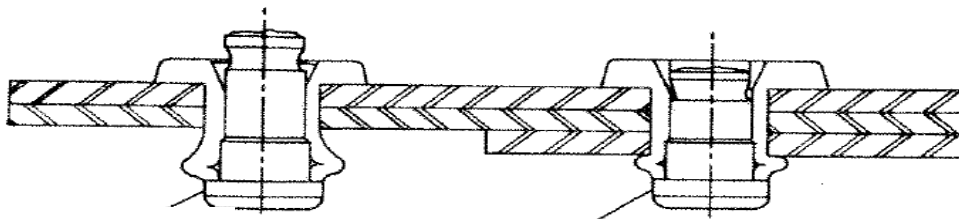

BOLT TOO LONG
PIN WILL PROTRUDE
TOO FAR

BOLT TOO SHORT
PIN WILL EXTEND
TOO FAR IN HEAD

A - Maximum allowable distance of locking collar above or below fastener head.

B - Maximum allowable distance of top of land on pin above fastener head.

C - Maximum allowable distance of top of land on pin below fastener head.

Blind Bolt Removal Tool Kits

Fasteners	Nom. Size	Kit No.
BP-T6, B100-T6	3/16"	105-60
BP-T8, B100-T8	1/4"	105-80

4-26. (cont)

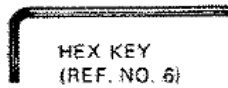
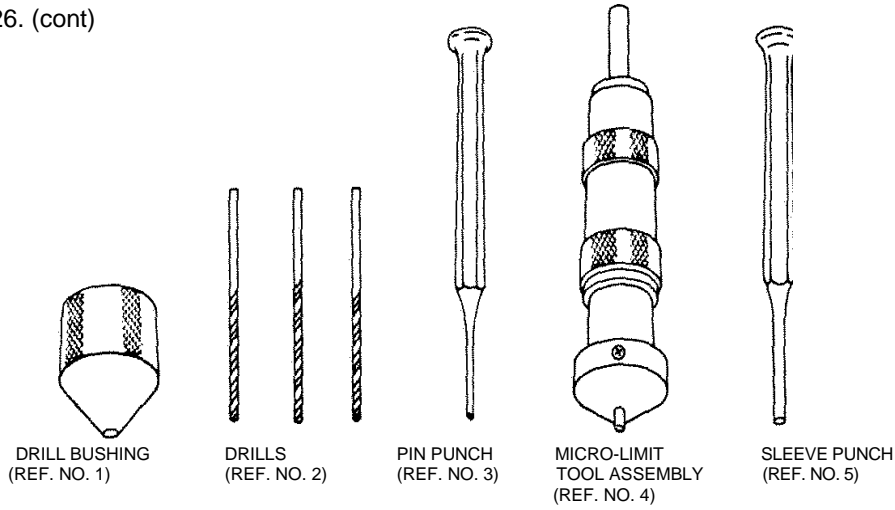

COMPOSITE PARTS LIST

Ref. No.	Description	105-60		105-80	
		Part No.	Req.	Part No.	Req.
4	Micro-Limit Tool Assembly	103601	1	103602	1
4-1	Micro-Limit Tool	103623	1	103623	1
4-2	Cutter Holder	110672-6	1	110672-6	1
4-3	Set Screw	501775	3	501775	3
4-4	Cutter	103606	1	103607	1
4-5	Anti-Rotation	103620	1	103621	1
3	Pin Punch	503010	1	503012	1
5	Sleeve Punch	503013	1	503015	1
2	Drill	503000	3	503001	3
1	Drill Bushing	103616	1	103617	1
6	Hex Key	502443	1	502443	1
	Case	103567	1	103567	1

4-26. (cont)

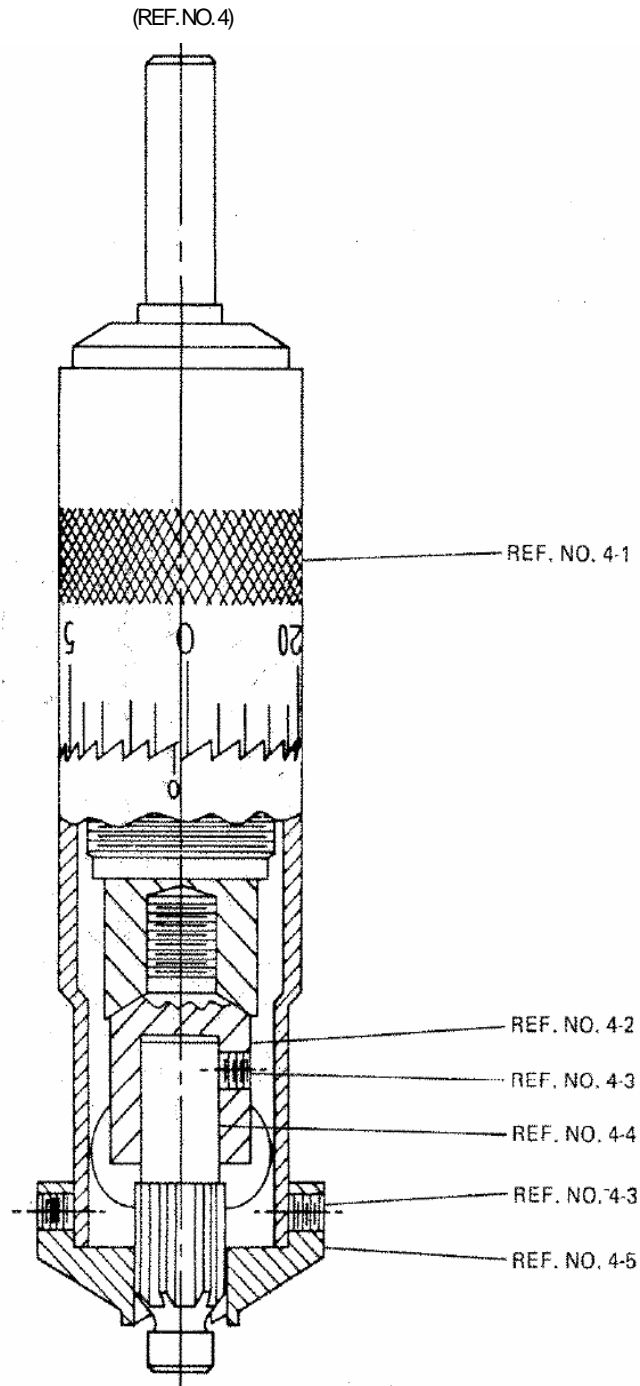

Micro-Limit Tool Assembly

4-26. (cont)

Drill

Nom. Size	Drill	Size	Min. Depth*	Bushing
3/16"	503000	.1200	.070	103616
1/4"	503001	.1562	.090	103617

* MAX. Depth + .020

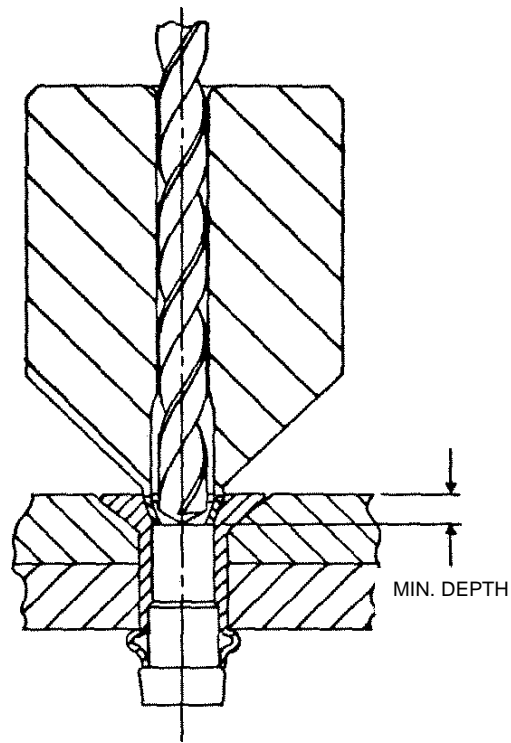

d. Operation I - Drill Pin

- (1) Place the drill bushing over the pin so that it rests squarely on the lock collar.
- (2) Using a drill with a maximum of 1250 RPM, drill to lock collar depth.

4-26. (cont)

Pin Punch

Nom. Size	Part No.	Size
3/16"	503010	3/32"
1/4"	503012	3/32"

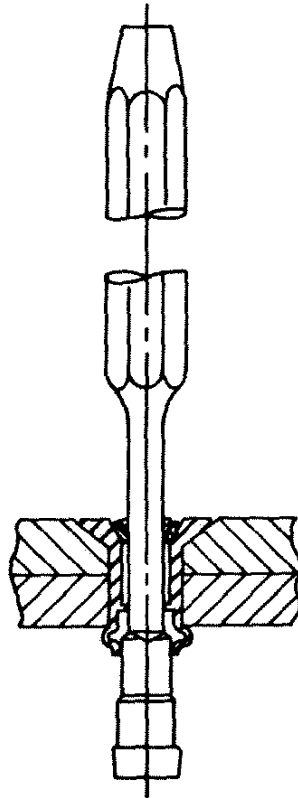

e. Operation II - Knock Out Pin

- (1) Position pin punch on the fastener and drive fastener pin out.
- (2) Remove remaining portion of pin and lock collar with any sharp pointed instrument.

4-26. (cont)

Cutter

Nom. Size	Holder	Cutter	Size	Anti-Rotation Cap
3/16"	103611	103606	3/16"	103620
1/4"	103611	103607	1/4"	103621

Head Height	
Protruding Head	C/Sunk Head
3/16"	.135
1/4 "	.140

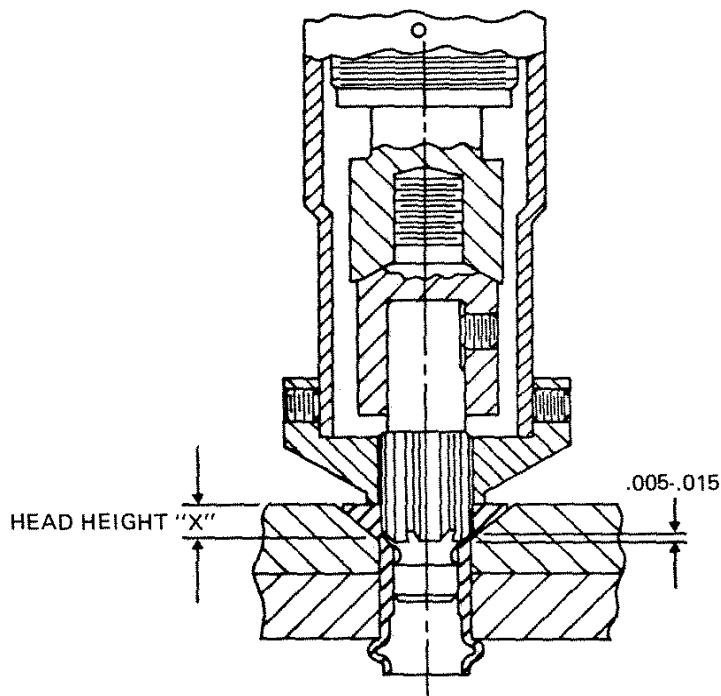

f. Operation III – Counterbore Sleeve

- (1) Adjust micro-limit tool to within .005 to .015 less than dimension "X".
- (2) Place anti-rotation cap firmly against head of fastener.
- (3) Counterbore to desired depth.

4-26. (cont)

Sleeve Punch

Nom. Size	Part No.	Size
3/16"	503013	3/16"
1/4 "	503015	1/4"

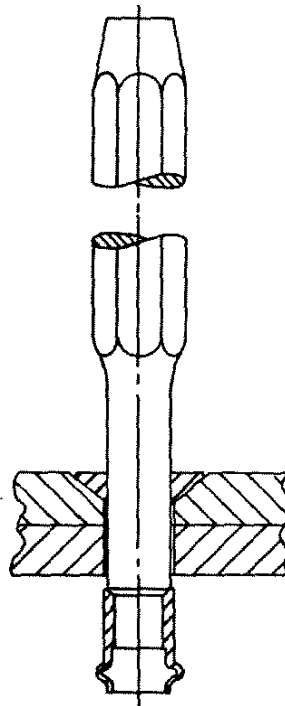

g. Operation IV — Knock Out Sleeve

(1) Position the sleeve punch in the sleeve and drive out lower portion of the sleeve.

(2) Tip the sleeve punch slightly and lift out the head of the fastener.

h. Tool Selection and Single Action Installation Sequence

NOTE

3/16" Fasteners are color identified green on pintail, shear cap or shear flange.

4-26. (cont)

SINGLE ACTION FASTENERS	DIA. DASH No.	NOM. DIA.	INSTALLATION TOOL SINGLE ACTION	NOSE ASSEMBLY SINGLE ACTION
MS90353s (SB100-T) M590354S (SBP-T) SB100-EU & SBP-EU OSB100-T & OSBP-T	06	3/16	115	99-681
MS90353 (B100-T) MS90354 (BP-T) MS21140 (B 100-EU) MS21141 (BP-EU) OB 100-T OBP-T	08	1/4	115	99-591

- (1) During the initial part of the driving operation, the sleeve is squeezed between the head of the pin and the nose of the rivet tool.
- (2) The head of the pin upsets the sleeve to form a strong, bulbed head on the blind side.
- (3) When the blind head has been formed, the tool automatically forces the locking collar (at the pintail end of the sleeve) into the conical space between the recess in the head and the locking groove in the pin. This locks the parts together permanently.
- (4) Pin is broken off in tension at the breakneck groove, substantially flush with the head of the sleeve. There is no projecting pin left to be cut off in a separate operation.

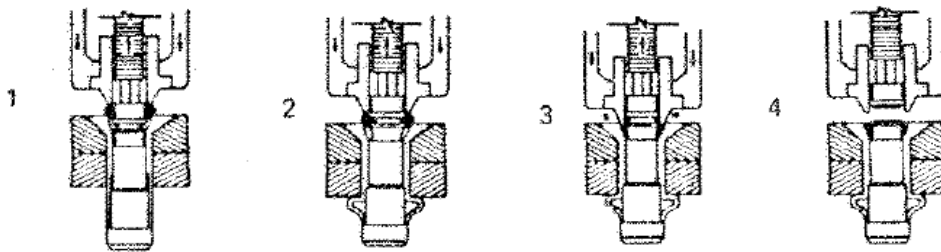

 4-27. REPAIR OF SMALL DENT OR DEPRESSION

NOTE

The following procedure covers repair of small dents or depressions in any shelter panel skin (damaged area not exceeding 2 square in. (12.9 sq. cm) or 0.25 in. 6.4 mm) deep and no evidence of delamination).

WARNING

Methylethylketone is flammable and toxic and shall be used only in a well-ventilated area away from all sparks or open flame. Gloves should be worn during use.

- a. Remove all traces of paint from damaged area with sandpaper (Item 17, Appendix E).
- b. Wipe sanded surface with clean cloth (Item 5, Appendix E) dampened in solvent (Item 20, Appendix E) and immediately wipe solvent from surface with a clean, dry cloth.
- c. Mask sanded surface with masking tape (Item 22, Appendix E).
- d. Mix small quantity of adhesive (Item 1, Appendix E) in accordance with manufacturer's instructions.
- e. Using spatula or putty knife, fill damaged area with adhesive.
- f. Apply heat using tripod base heat lamp, Appendix B, Item 15, at 200° F (93.3°C) for 40 to 60 minutes to fully cure adhesive. Alternate cures: 150° F for 4 hours or 75° F for 72 hours.
- g. Sand surface of cured adhesive to conform to surrounding area.
- h. Remove masking tape and clean repaired surface.
- i. Refinish in accordance with paragraph 4-37.

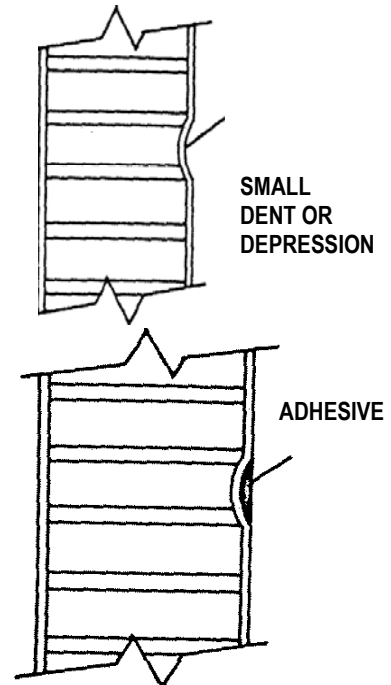

4-28. REPAIR OF DEPRESSION OR SMALL PUNCTURE

NOTE

The following procedure covers repair of a depression or small puncture in any shelter panel skin (depression exceeding 2 square in. (12.9 sq cm) or deeper than 0.25 in. (6.4 mm) but not larger than 4 square in. (25.8 sq. cm) or puncture not larger than 1 square in. (6.5 .sq cm)).

WARNING

Wear safety goggles for eye protection from flying metal chips.

- a. Drill two 1/8 in. (3.18 mm) diameter holes within damaged area.
- b. Dry panel per paragraph 4-25, if required
- c. Mix small quantity of adhesive (Item 1, Appendix E) in accordance with manufacturer's instructions.
- d. Transfer adhesive to caulking gun and inject adhesive through two drilled holes to fill core cells completely.
- e. Apply heat using tripod base heat lamp, Appendix B, Item 15, at 200°F (93.3°C) for 40 to 60 minutes to fully cure adhesive. Alternate cures: 150° F for 4 hours or 75° F for 72 hours.
- f. Check by tapping damaged area to ensure complete filling of cells.
- g. Sand damaged area with sandpaper (Item 17, Appendix E) to remove all traces of paint and excess adhesive.

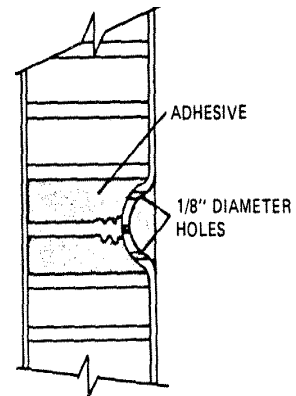

WARNING

Methylethylketone is flammable and toxic and shall be used only in a well-ventilated area away from all sparks or open flame. Gloves should be worn during use.

4-28. (cont)

- h. Wipe sanded surface with clean cloth (Item 5, Appendix E) dampened in solvent (Item 20, Appendix E) and immediately wipe solvent from surface with a clean, dry cloth.
- i. Mask sanded surface with masking tape (Item 22, Appendix E).
- j. Mix small quantity of adhesive in accordance with manufacturer's instructions.
- k. Using spatula or putty knife, fill damaged area with adhesive.
- l. Apply external heat source at 200°F (93.3°C) for 40 to 60 minutes to fully cure adhesive.
- m. Sand surface of cured adhesive to conform to surrounding area.
- n. Remove masking tape and clean repaired surface.
- o. Refinish in accordance with section 4-37.

4-29. REPAIR OF PUNCTURE WITH MINIMAL DAMAGE TO CORE

NOTE

The following procedure covers repair of puncture in any shelter panel skin with minimal core damage, (damaged area not exceeding 14 square in. (90.3 sq cm)). Use hand router to cut patches and openings.

- a. Dry panel per paragraph 4-25, if required.
- b. Using portable electric router, Appendix B, Item 14, cut aluminum patch (Item 4, Appendix E) one inch larger all around than damaged area.

WARNING

Wear safety goggles for eye protection from flying metal chips.

- c. Layout and drill holes as shown.
- d. Center patch over damaged area and mark patch outline on panel skin.

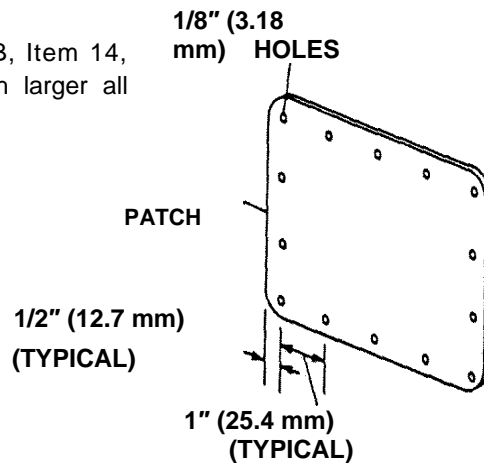

4-29. (cont)

- e. Sand all paint from damaged panel skin within marked area, with sandpaper (Item 17, Appendix E).
- f. Center patch over damaged area and drill No. 30 diameter holes in panel skin. Use holes in patch as a template.
- g. Index patch and panel skin with a mark to allow patch to be replaced in same orientation.
- h. Deburr all drill holes.

WARNING

Methylethylketone is flammable and toxic and shall be used only in a well-ventilated area away from all sparks or open flame. Gloves should be worn during use.

i. Wipe damaged area and patch with a clean cloth (Item 5, Appendix E) dampened in solvent (Item 20, Appendix E) and immediately wipe solvent from surfaces with a clean, dry cloth. Do not allow solvent to get into exposed core.

j. Mix sufficient amount of adhesive (Item 1, Appendix E) in accordance with manufacturer's instructions.

k. Pack adhesive in puncture and all exposed core cells. Use mixing sticks (Item 21, Appendix E) to pack adhesive and obtain a smooth surface.

l. Apply a thick film of remaining adhesive to mating surface of patch.

m. Place patch over prepared area in same orientation used in step f.

n. Align holes and, using hand blind riveter, install 1/8 in. (3.18 mm) diameter blind rivets (Items 15-16, Appendix E). (Refer to paragraph 4-26.)

o. Clean repaired surface.

p. Caulk around patch. (Refer to paragraph 4-36.)

q. Refinish in accordance with paragraph 4-37.

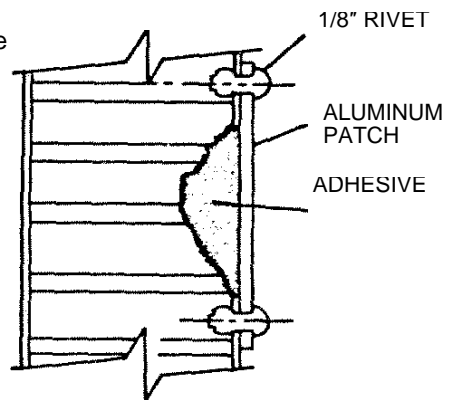

 4-30. REPAIR OF PUNCTURE WITH CORE FRACTURE

NOTE

The following procedure covers repair of any shelter panel punctured skin with core fracture, (damaged area not exceeding 25 square in. (161 sq cm)). Use hand router to cut patches and openings.

WARNING

Wear safety goggles for eye protection from flying metal chips.

- a. Dry panel per paragraph 4-25, if required.
- b. Cut an opening through panel skin with a portable electric router, Appendix B, Item 14, that is one inch greater than damaged area. Avoid sharp corners in opening.
- c. Peel damaged portion of skin from core by lifting and rolling skin.
- d. Remove all loose core from exposed core area with compressed air.
- e. Cut aluminum patch (Item 4, Appendix E) one inch larger all around than cutout opening.
- f. Layout and drill holes as shown.
- g. Mix sufficient amount of adhesive (Item 1, Appendix E) in accordance with manufacturer's instructions.
- h. Pack adhesive in core cells to fill exposed area above surface of panel skin.
- i. Apply heat using tripod base heat lamp, Appendix B, Item 15, at 200°F (93.3°C) for 40 to 60 minutes to fully cure adhesive. Alternate cures: 150° F for 4 hours or 75° F for 72 hours.

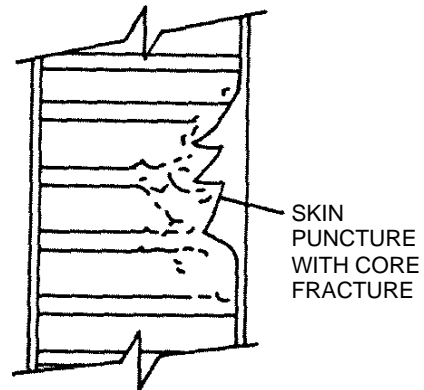

4-30. (cont)

j. Sand cured adhesive with sandpaper (Item 17, Appendix E) to obtain a smooth contour with surface of panel skin.

k. Center patch over adhesive-filled area and mark patch outline on panel skin.

l. Sand all paint from damaged panel skin within marked area.

m. Center patch over filled area and drill No.30 diameter holes in panel skin. Use holes in patch as a template.

n. Index patch and panel skin with a mark to allow patch to be replaced in same orientation.

o. Deburr all drill holes.

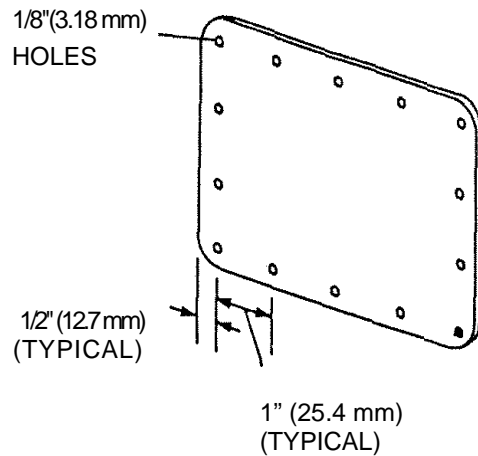

WARNING

Methylethylketone is flammable and toxic and shall be used only in a well-ventilated area away from all sparks or open flame.

p. Wipe damaged area and patch with a clean cloth (Item 5, Appendix E) dampened in solvent (Item 20, Appendix E) and immediately wipe solvent from surfaces with a clean, dry cloth.

q. Mix sufficient amount of adhesive in accordance with manufacturer's instructions to coat one side of patch.

r. Apply a thick film of adhesive to mating surface of patch.

s. Place patch over prepared area in same orientation used in step k.

t. Align holes and, using hand blind riveter, install 1/8 in. (3.18 mm) diameter blind rivets (Items 15-16, Appendix E). (Refer to paragraph 4-26.)

u. Clean repaired surface.

v. Caulk around repair patch. (Refer to paragraph 4-36.)

w. Refinish in accordance with paragraph 4-37.

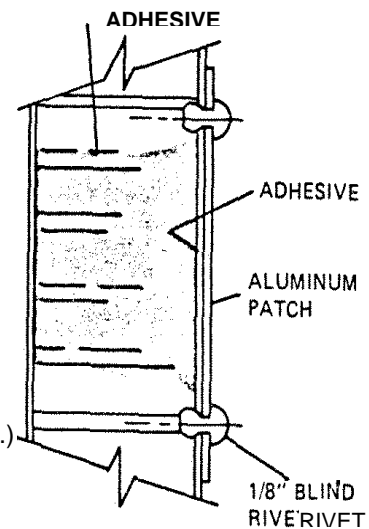

4-31. REPAIR OF DAMAGE WITH EXTENDED CRACKS

NOTE

The following procedure covers repair of extended cracks (such as a long cut) in panel skin (damaged area does not exceed 36 in. (91.44 cm) square).

- a. Dry panel per paragraph 4-25, if required.
- b. Using portable electric router, Appendix B, Item 14, cut aluminum patch (Item 4, Appendix E) one inch larger all around than damaged area.

WARNING

Wear safety goggles for eye protection from flying metal chips.

- c. Layout and drill 1/8 in. (3.18 mm) holes as shown.

- d. Stop-drill all cracks with No. 30 (3.27 mm) drill bit.

- e. Center patch over damaged area and mark patch outline on panel skin.

- f. Sand all paint from damaged skin within marked area with sandpaper (Item 17, Appendix E).

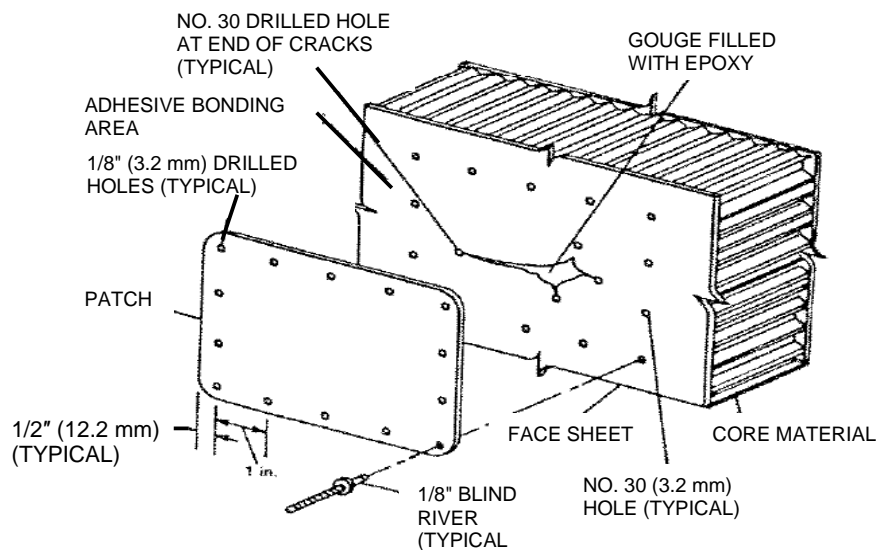
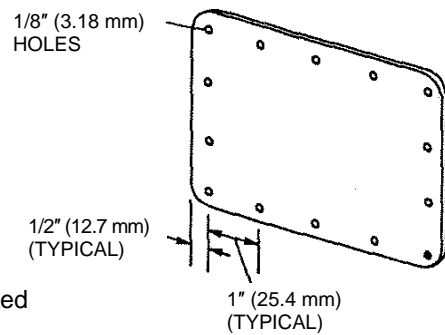

4-31. (cont)

- g Center patch over damage area and drill No. 30 diameter holes in panel skin. Use holes in patch as a template.
- h. Index patch and panel skin with a mark to allow patch to be replaced in same orientation.
- i Deburr all drill holes.

WARNING

Methylethylketone is flammable and toxic and shall be used only in a well-ventilated area away from all sparks or open flame.

- j. Wipe damaged area and patch with a clean cloth (Item 5, Appendix E) dampened in solvent (Item 20, Appendix E) and immediately wipe solvent from surfaces with a clean, dry cloth.
- k. Mix sufficient amount of adhesive (Item 1, Appendix E) in accordance with manufacturer's instructions.
- l. Pack adhesive in core cells to fill exposed area above surface of panel skin.
- m. Apply heat using tripod base heat lamp, Appendix B, Item 15, at 200° F (93.3° C) for 40 to 60 minutes to fully cure adhesive. Alternate cures: 150° F for 4 hours or 75° F for 72 hours.
- n. Sand cured adhesive with sandpaper to obtain a smooth contour with surface of panel skin.
- o. Wipe sanded area and patch with a clean cloth dampened in solvent and immediately wipe solvent from surfaces with a clean, dry cloth.
- p. Mix sufficient amount of adhesive in accordance with manufacturer's instructions to coat one side of patch.
- q. Apply a thick film of adhesive to mating surface of patch.
- r. Place patch over prepared area in same orientation used in step g.
- s. Align holes and using hand blind riveter (Appendix B, Item 2), install 1/8 in. (3.18 mm) diameter blind rivets (Items 15-16, Appendix E). (Refer to paragraph 4-26.)
 - t. Clean repaired surface.
 - u. Caulk around repair patch. (Refer to paragraph 4-36.)
 - v. Refinish in accordance with paragraph 4-37.

 4-32. REPAIR OF PUNCTURE THROUGH ONE SKIN AND CORE

NOTE

The following procedure covers repair of panel puncture through one skin with core damage, (damaged area does not exceed 100 square in. (645 sq. cm)).

- a. Cut an opening through panel skin with portable electric router, Appendix B, Item 14, that is one inch greater than damaged area. Avoid sharp corners in opening.

NOTE

Openings may be oval, circular, square, or rectangular with rounded corners.

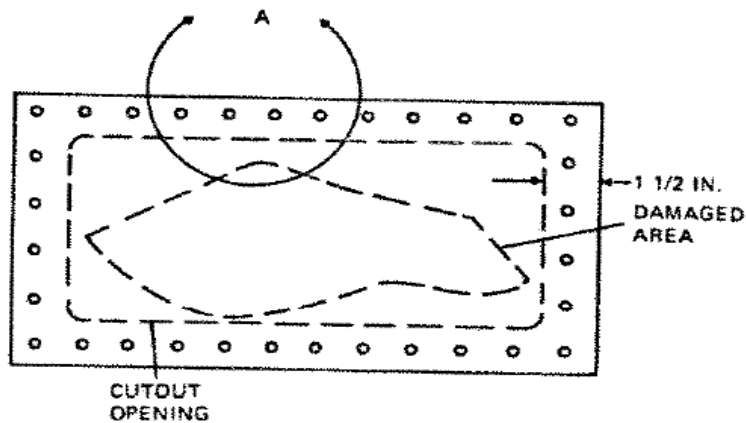
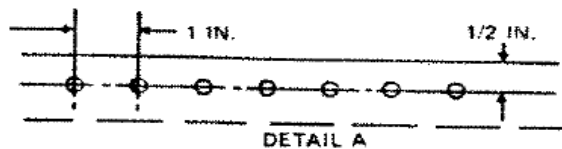

- b. Peel damaged portion of skin from core by lifting and rolling skin.
- c. Trim core area with a knife to same size as opening while leaving small amount of core material on opposite skin.
- d. Cut aluminum patch 1 1/2 inch (3.8 cm) (Item 4, Appendix E) larger all around than cutout opening.
- e. Layout and drill 1/8 inch (3.18 mm) diameter holes in patch. (See Detail A.)

4-32. (cont)

- f. Cut core material (Items 7-10, Appendix E) same size as cutout opening. Core plug should be flush with or slightly lower than panel skin surface.
- g. Center patch over cutout opening and mark patch outline on panel skin.
- h. Drill No. 30 diameter holes in panel skin with patch as template.
- i. Sand all paint from panel skin within marked area with sandpaper (Item 17, Appendix E).
- j. Index patch and panel skin with a mark to allow patch to be replaced with same orientation.
- k. Deburr drill holes and sand all paint from panel skin within marked area.
- l. Clean loose core material, dust, and chips from cutout opening.

WARNING

Methylethylketone is flammable and toxic and shall be used only in a well-ventilated area away from sparks or open flame. Gloves should be worn during use.

- m. Wipe panel skin within marked area and patch with a clean cloth (Item 5, Appendix E) dampened with solvent and immediately wipe solvent from surfaces with a clean, dry cloth.
- n. Mix sufficient amount of adhesive (Item 1, Appendix E) in accordance with manufacturer's instructions.

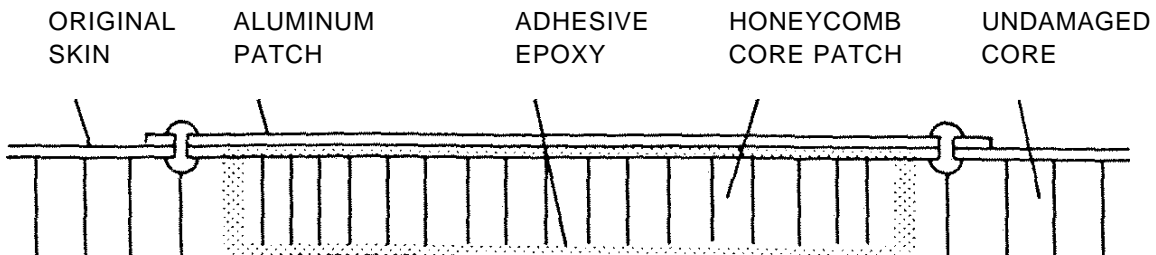

- o. Apply an even coat of adhesive to cutout core surfaces.
- p. Insert core plug in cutout opening and press firmly in place.
- q. Apply an even coat of adhesive around core plug and fill any gaps around plug.

4-32. (cont)

- r. Apply heat using tripod base heat lamp (Appendix B, Item 15) at 200° F (93.3° C) for 40 to 60 minutes to fully cure adhesive. Alternate cures: 150° F (65.6° C) for 4 hours or 75° F (23.9° C) for 72 hours.
- s. Sand cured adhesive with sandpaper to obtain a smooth contour with surface of panel skin.
- t. Apply an even coat of adhesive to mating surface of patch.
- u. Place patch over prepared area in same orientation as step j.
- v. Align holes and using hand blind riveter (Appendix B, Item 2), install 1/8 inch (3.18 mm) diameter blind rivets (Items 15-16, Appendix E). (Refer to 4-26.)
- w. Clean repaired surface.
- x. Caulk around repair patch. (Refer to 4-36.)
- v. Refinish in accordance with 4-37.

4-33. REPAIR OF PUNCTURE THROUGH BOTH SKINS AND CORE

NOTE

The following procedures cover repair of panel puncture through both skins and core (damage area does not exceed 100 square in. (645 sq. cm)). Use hand router to cut patches and openings.

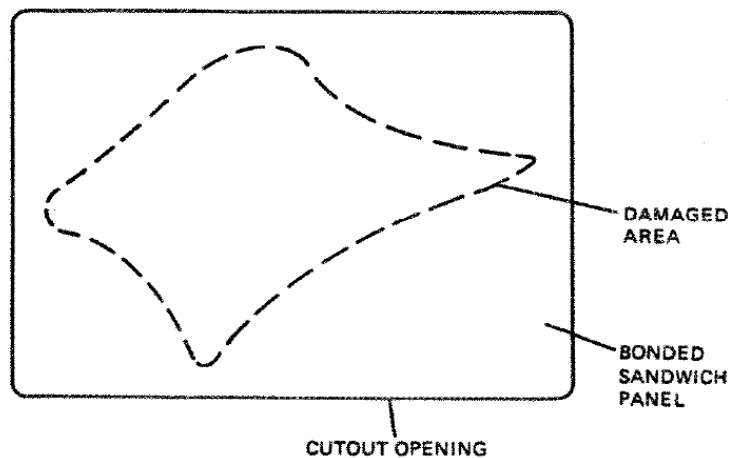

4-33. (cont)

- a. Cut an opening through panel skin with portable electric router (Appendix B, Item 14) that is one inch greater than damaged area. Avoid sharp corners in opening.

NOTE

Openings may be oval, circular, square, or rectangular with rounded corners. Ensure core ribbon direction is same as panel. Dry panel per paragraph 4-25, if required.

- b. Cut a core plug (Items 7-10, Appendix E) and two aluminum patches (Item 4, Appendix E) one to three inches larger all around than cutout opening.
- c. Mix sufficient amount of adhesive (Item 1, Appendix E) in accordance with manufacturer's instructions to bond two patches to core plug.

WARNING

Methylethylketone is flammable and toxic and shall be used only in a well-ventilated area away from sparks or open flame. Gloves should be worn during use.

- d. Wipe patches with a clean cloth (Item 5, Appendix E) dampened with solvent and immediately wipe solvent (Item 20, Appendix E) from surfaces with a clean, dry cloth.
- e. Apply a thick coat of adhesive to one side of each patch.
- f. Place core plug between two patches to create a sandwich panel.
- g. Apply pressure and heat using tripod base heat lamp (Appendix B, Item 15) at 200° F (93.9° C) for 40 to 60 minutes to fully cure adhesive.
- h. Cut bonded sandwich panel to same size as cutout opening (step a). Ensure core ribbon direction is same as panel.
- i. Cut two aluminum patches 1 1/2 inch (3.8 cm) larger all around than cutout opening.
- j. Layout and drill 1/8 inch (3.18 mm) diameter holes in patches.
- k. Position bonded sandwich panel in cutout opening.

4-33. (cont)

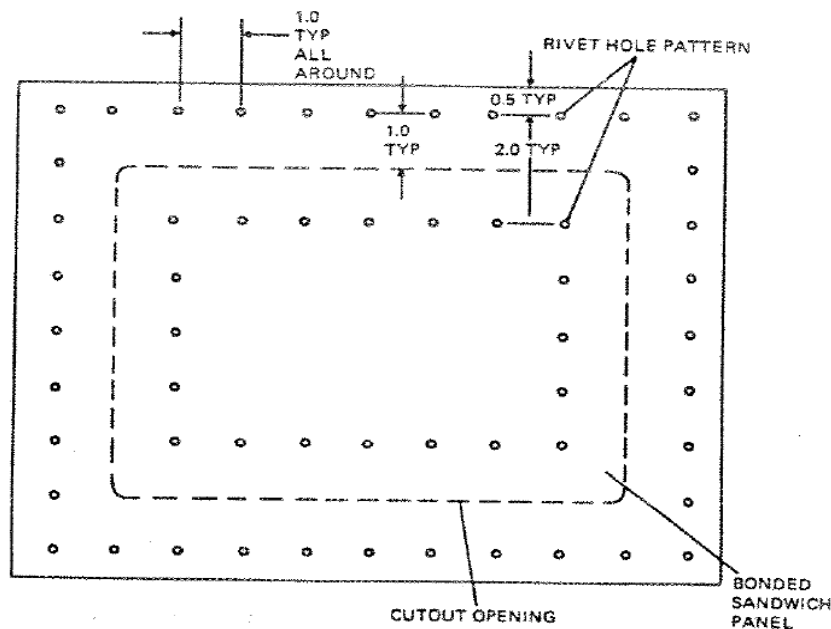

- l. Center patches, one on each side of panel, over cutout opening.
- m. Drill No. 30 (3.27 mm) diameter holes in panel skins and bonded sandwich panel with patches as templates.
- n. Mark each patch outline on panel skin, and sand all paint from panel skin within marked area with sandpaper (Item 17, Appendix E).
- o. Index each patch and panel skin with a mark to allow patches to be replaced with same orientation.
- p. Remove patches and bonded sandwich panel.
- q. Dehurr drill holes and sand all paint from panel skin within marked areas.
- r. Clean loose core material, dust, and chips from cutout opening.
- s. Wipe panel skin within marked areas, two patches, and bonded sandwich panel metal skin with a clean cloth dampened with solvent. Immediately wipe solvent from surfaces with a clean, dry cloth.
- t. Mix sufficient amount of adhesive in accordance with manufacturer's instructions.
- u. Apply a thick coat of adhesive to inside surfaces of panel cutout opening, bonded sandwich panel, and two patches.

4-33. (cont)

- v. Position bonded sandwich panel in cutout opening.
- w. Fill any gaps between cutout opening and bonded sandwich panel with adhesive.

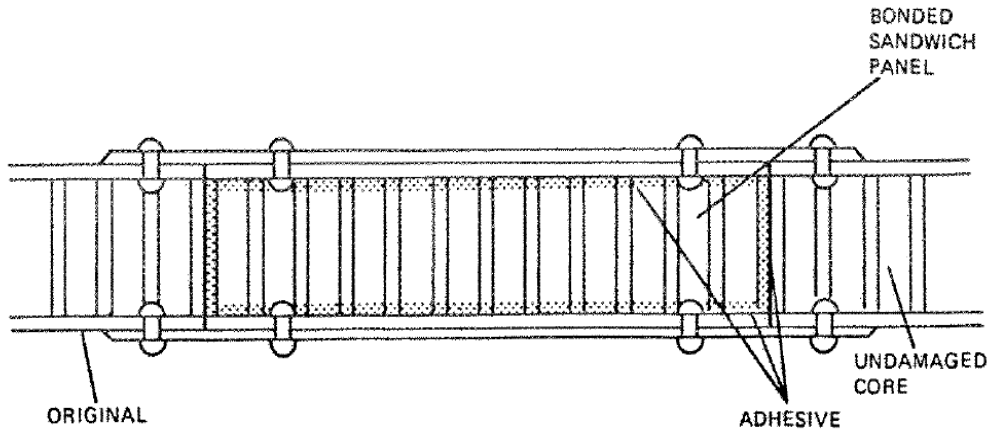

- x. Place patches over prepared areas in same orientation as step o.
- y. Align holes and using hand blind riveter (Appendix B, item 2), install 1/8 inch (3.18 mm) diameter blind rivets (Items 15-16, Appendix E). (Refer to 4-26.)
- z. Clean repaired surfaces.
- aa. Caulk around repair patches. (Refer to 4-36.)
- aa. Refinish in accordance with 4-37.

4-34. SHELTER BODY SEALS REPLACEMENT

WARNING

Wear safety goggles for eye protection from flying metal chips.

- a. If defective seal has a retaining strip, drill out blind rivets and remove retaining strip. (Refer to paragraph 4-26.)
- b. Remove defective seal and strip old sealant from bonding surface.

WARNING

Methylethylketone is flammable and toxic and shall be used only in a well-ventilated area away from all sparks or open flame.

4-34. (cont)

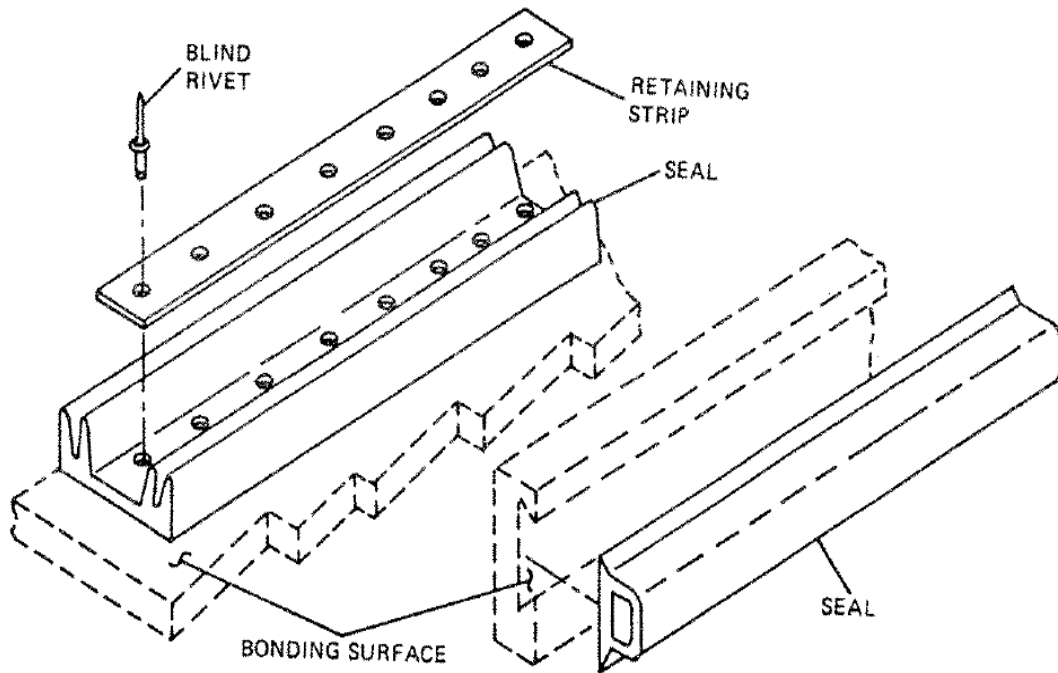

- c. Sand using sandpaper (Item 17, Appendix E) only if required to remove material not taken off in preceding step.
- d. Wipe bonding surface with a clean cloth (Item 5, Appendix E) dampened with solvent (Item 20, Appendix E) and immediately wipe solvent from surface with a clean, dry cloth.

CAUTION

Seals shall not be washed with any aromatic hydrocarbon (such as benzene, toluene, or xylene) which will cause deterioration.

- e. Clean seal with a lint-free cloth by dry wiping prior to bonding.
- f. Brush sealant (Item 18, Appendix E) on mating surfaces of seal and bonding surface.
- g. When sealant is tacky (approximately 5 minutes), place seal in position, press firmly to seat and ensure contact with mating surface.
- h. If seal is the type that has a retaining strip, seal shall be bonded prior to riveting retaining strip. (Refer to paragraph 4-26 for blind rivet installation.)
- i. After installing rivets, using hand blind riveter, cover rivets and seal with sealing compound (Item 19, Appendix E).

4-35. THREADED INSERTS REPLACEMENT

NOTE

Inserts installed in extrusions are not potted. For removal of these inserts, perform steps a and b only. Knock out insert and replace with same type.

- a. Depending on insert size, select a drill bit in size range listed below.

Insert Thread Size	Drill Size Range inches (mm)
10-32	7/16-15/32 (11/12.4)
1/4-28	17/32-21/32 (13.5/16/7)
5/16-24	39/64-21/32 (15.5/16.7)
3/8-24	43/64-23/32 (17/18.3)

WARNING

Wear safety goggles for eye protection against flying chips.

- b. Using selected drill bit, drill head flange from insert.
- c. Drill small holes around insert body in potting compound to approximate depth of insert. Take care not to damage area around insert beyond hole diameter of step above. Do not drill through to opposite skin.
- d. Install bolt of corresponding thread size in insert.
- e. Use wrench to break insert loose.
- f. Install bolt end in a hand drill motor.
- g. Spin loose insert to build up heat which will allow insert to be removed from hole.
- h. Remove loose chips and clean out hole.

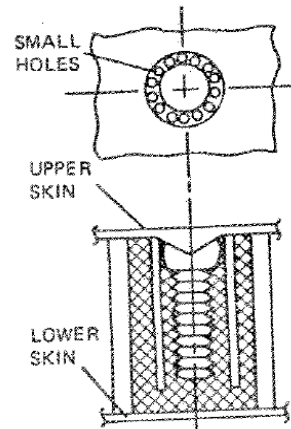
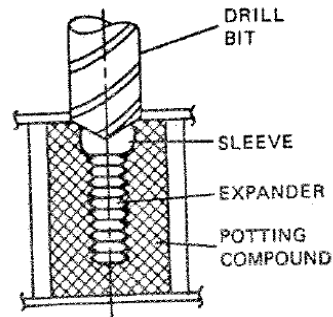

NOTE

Replacement insert is a spool type potted insert.

4-35. (cont)

i. Depending on replacement insert size, select a drill bit from sizes listed below. After drilling small holes around periphery of insert, the remaining hole will be much larger than the recommended drill size.

Insert Thread Size	Insert Outside	
	Diameter inches (mm)	Drill Size inches (mm)
1/4-28	0.437 (11.1)	29/64 ± 0.010 (11.5 ± 0.25)
5/16-24	0.500 (12.7)	33/64 ± 0.010 (13.1 ± 0.25)
10-32 &, 3/8-16	0.562 (14.3)	37/64 ± 0.010 (14.7 ± 0.25)
1/4-28 & 5/16-24	0.687 (17.5)	45/64 ± 0.010 (17.9 ± 0.25)
3/8-24	0.750 (19.1)	49/64 ± 0.010 (19.5 ± 0.25)

j. Using selected drill bit, drill through panel skin to approximate depth of insert to be installed.

NOTE

Take care not to drill through opposite skin.

k. Install long end of Allen wrench into drill chuck and insert short end in predrilled hole and remove additional honeycomb core to one inch (2.54 mm) in diameter. Leave from 1/8 in. (3.2 mm) to 1/4 in. (6.4 mm) of core at bottom of hole.

l. Remove loose honeycomb and foam insulation, if applicable, from hole.

m. Degrease insert by cleaning with solvent (Item 20, Appendix E).

NOTE

After cleaning, handle insert with clean, white gloves (Item 11, Appendix E).

n. Mask skin area around hole with masking tape (Item 22, Appendix E) approximately 3" x 3".

4-35. (cont)

o. Prepare aluminum plate (Item 24, Appendix E) approximately 1/8 in. (3.2 mm) thick by 2 in. (50.8 mm) square with a center hole equal to bolt thread outer diameter (replacement insert thread size).

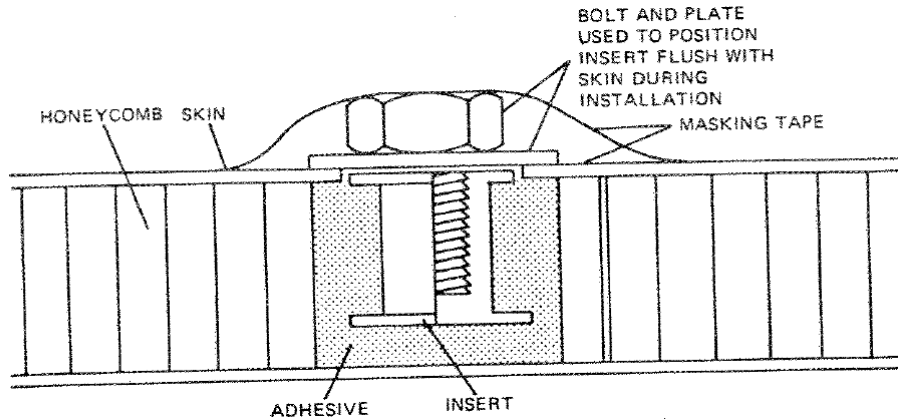

- p. Install bolt through plate and into insert. Hand-tighten insert against plate.
- q. Mix sufficient amount of adhesive (Item 1, Appendix E) in accordance with manufacturer's instructions.
- r. Fill prepared hole completely with mixed adhesive. Make sure there are no air pockets.
- s. Force preassembled insert into filled hole with a threading motion until plate is flush against skin.
- t. Remove excess adhesive (squeeze out) from work area.
- u. Apply masking tape over bolt to maintain alignment during curing cycle.
- v. Cure non-structural inserts for at least 4 hours at 75° F.
- w. Inserts on which there is structural dependency should be cured at 75° F for 72 hours.
- x. After cure, remove masking tape, bolt, and plate.
- y. Clean skin as required. (Refer to Appendix E, Items 5 and 20.)
- z. Refinish in accordance with paragraph 4-37.

4-35. (cont)

aa. Non-Potted Insert Manual Installation

(1) Select fastener header model (Appendix B, Item 7 or 8) applicable to insert to be installed.

(2) Lubricate header jackscrew threads with spray lubricant (Appendix E, Item 25).

(3) Assemble sleeve and expander or one-piece insert on header pull-up stud to engage all threads on stud.

(4) Advance header anvil until it is tight on head of sleeve or one-piece insert.

(5) Position prepared assembly in hole.

(6) Place hex wrench (supplied with header) in socket of header jackscrew and place box-end or adjustable wrench (Appendix B, Item 9) on hex nut approximately 60° rotation from line of hex wrench.

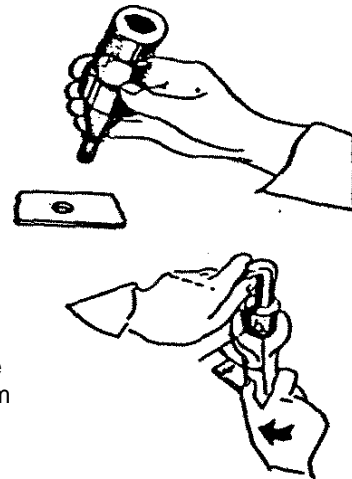

NOTE

A box-end ratchet wrench is preferable as the pull on the expander or one-piece insert body should be made at a uniform rate and as quickly as possible.

(7) Hold header perpendicular to plane of work. Hold jackscrew stationary with hex wrench. Turn hex nut in clockwise direction through 60° angle and repeat until firm resistance indicates complete upset of sleeve or one-piece insert body. Approximate number of turns required to upset is as follows:

<u>Thread Size</u>	<u>Turns (Min Grip)</u>	<u>Turns (Max Grip)</u>
10-32	1-3/4	1
1/4-28	2-1/4	1-1/2
5/16-24	2-3/4	1-3/4
3/8-24	2-1/4	1-1/2

(8) Break hex nut loose with counterclockwise rotation. Remove both wrenches from header.

(8) Remove header from installed insert by rotating entire header in counterclockwise direction.

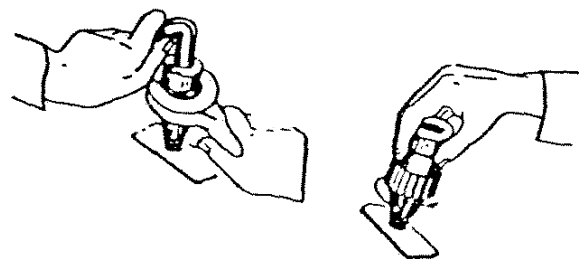

4-36. CAULKING REPAIRED AREAS

a. Mix sufficient amount of sealing compound (Item 19, Appendix E) in accordance with manufacturer's instructions.

NOTE

Maximum application life of sealing compound is 2 hours.

b. Just prior to application of sealing compound, clean surface to be sealed with cloth (Item 5, Appendix E) dampened with solvent (Item 20, Appendix E).

c. Dry with a clean cloth before solvent evaporates in order to prevent contamination.

d. Apply sealing compound with caulking gun (or spatula) in 1/8 inch (3.18 mm) minimum fillets.

e. Nominal curing time is 72 hours at 75° F.

4-37. PAINT REFINISHING

PAINT DATA FOR SHELTERS WITH OLDER MODEL NQOB CIRCUIT BREAKER PANELS

Use	Type	Specification Color	Color code FED STD 595
Interior Paint	Expoxy-Polyamide	MIL-C-22750 Gloss White	17925
Exterior Paint	Coating, Aliphatic Polyurethane	MIL-C-46168 Sand	33303
Primer	Primer Coating, Epoxy Polyamide	MIL-P-23377	
Floor Primer	Primer, Epoxy Polyamide Type 1	MIL-P-23377 Deep Yellow	
Floor Paint	Walkway Compound	MIL-W-5044 Type I Gray	26251

PAINT DATA FOR SHELTER WITH NEW MODEL NQOD CIRCUIT BREAKER PANELS

Use	Type	Specification Color	Color code FED STD 595
Interior Paint	Coating, Urethane Aliphatic Isocyanate	MIL-C-83286 Gloss White	17925
Exterior Paint	Coating, Aliphatic Polyurethane	MIL-C-46168 Sand	
Primer	Primer Coating, Epoxy Polyamide	MIL-P-23377	
Floor Primer	Primer, Epoxy Polyamide Type 1, MIL-P-23377	TT-P-1757	
Floor Paint	Walkway Compound	MIL-W-5044 Type I Gray	26251

4-37. (cont)

NOTE

Paint data is also listed on color code identification plate on personnel endwall.

- a. Prepare surface for painting by removing all corrosion by wire brushing, sanding, or application of corrosion-removing compounds.
- b. Chemically treat all aluminum parts in accordance with MIL-C-5541, Class 1A.
- c. Areas to be painted shall be free of dust, residue, and cleaning compounds before refinishing.
- d. Solvent, primer, or paint shall not be applied to seals or non-metal parts. Mask such parts with masking tape for protection.
- e. Mix and apply epoxy polyamide primer coating (Item 6, Appendix E) in accordance with MIL-C-22751.
- f. Allow to dry thoroughly before applying finish coat.
- g. Mix and apply paint in accordance with manufacturer's instructions.
- h. Apply two separate, uniform coats. Make sure there are no sags or runs.
- i. Allow first coat to dry before applying second coat.

4-38. DECAL REMOVAL AND REPLACEMENT

- a. Use a putty knife (or similar tool) to peel decals off all surfaces.

WARNING

Methylethylketone (MEK) is flammable and toxic and must be used only in a well-ventilated area away from all sparks or open flame. Gloves should be worn during use.

- b. Clean all decal mounting surfaces. (Refer to Appendix E, Items 5 and 20.)
- c. Remove protective liner from adhesive backing of decal and apply. Use hand pressure or squeegee to ensure proper adhesion.

4-39. ELECTRICAL SYSTEM SCHEMATIC DIAGRAM – 60 AMP SERVICE

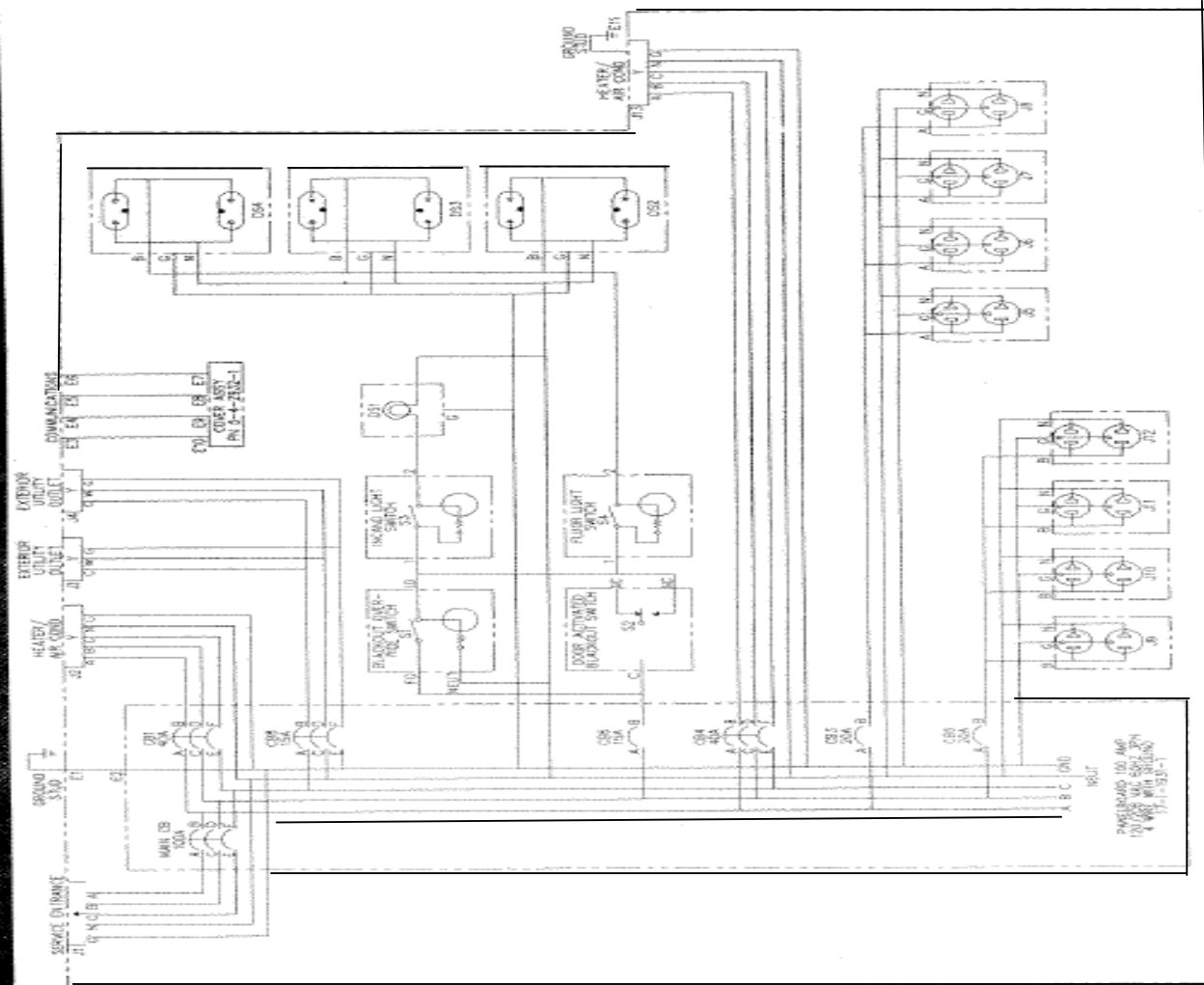

4-40. WIRE LIST FOR 60 AMP SERVICE

Wire No	Inch Long	Size Awg And Color	From	To
W1-1	18	12 RED	E3	E7
W1-2	18	12 RED	E4	E8
W1-3	18	12 RED	E5	E9
W1-4	18	12 RED	E6	E10
W2-1	8	12 RED	CB6-B	S1-F0
W2-2	88	12 RED	CB6-B	S2-C
W2-3	90	12 RED	S1-LO	S3-1
W2-4	87	12 RED	S2-NO	S1-LO
W2-5	27	12 RED	S2-NO	S4-1
W2-6	81	12 RED	S3-2	DS1
W2-7	184	12 RED	S4-2	DS2-B
W2-8	90	12 RED	DS2-B	DS3-B
W2-9	90	12 RED	DS3-B	DS4-B
W2-10	78	12 WHT	DS1	NEUT
W2-11	97	12 WHT	DS2-N	NEUT
W2-12	90	12 WHT	DS2-N	DS3-N
W2-13	90	12 WHT	DS3-N	DS4-N
W2-14	97	12 GRN	DS2-G	GND
W2-15	90	12 GRN	DS2-G	DS3-G
W2-16	90	12 GRN	DS3-G	DS4-G
W2-17	78	12 GRN	DS1-G	GND
W2-18	20	12 BLU	CB8-B	J3-C
W2-19	20	12 BLU	CB8-B	J4-C
W2-20	20	12 WHT	J3-W	NEUT
W2-21	20	12 WHT	J4-W	NEUT
W2-22	20	12 GRN	J3-G	GND
W2-23	20	12 GRN	J4-G	GND
W2-24	30	12 WHT	S1-NEUT	NEUT
W2-25	10	12 BARE	S2-GND	DS1-BOX GND
W2-26	24	12 GRN	DS1-G	S4-BOX GND
W3-1	52	12 BLK	CB3-B	J5-A
W3-2	68	12 BLK	J5-A	J6-A
W3-3	68	12 BLK	J6-A	J7-A
W3-4	68	12 BLK	J7-A	J8-A
W3-5	52	12 WHT	J5-N	NEUT
W3-6	68	12 WHT	J5-N	J6-N

4-40. (cont)

Wire No	Inch Long	Size Awg And Color	From	To
W3-7	68	12 WHT	J6-N	J7-N
W3-8	68	12 WHT	J7-N	J8-N
W3-9	52	12 GRN	J5-G	GND
W3-10	68	12 GRN	J5-G	J6-G
W3-11	6	12 BARE	J5-G	BOX GND
W3-12	68	12 GRN	J6-G	J7-G
W3-13	6	12 BARE	J6-G	BOX GND
W3-14	68	12 GRN	J7-G	J8-G
W3-15	6	12 BARE	J7-G	BOX GND
W3-16	6	12 BARE	J8-G	BOX GND
W3-17	123	12 RED	CB5-B	J9-B
W3-18	68	12 RED	J9-B	J10-8
W3-19	68	12 RED	J10-B	J11-B
W3-20	68	12 RED	J11-8	J12-B
W3-21	123	12 WHT	J9-N	NEUT
W3-22	68	12 WHT	J9-N	J10-N
W3-23	68	12 WHT	J10-N	J11-N
W3-24	68	12 WHT	J11-N	J12-N
W3-25	123	12 GRN	J9-G	GND
W3-26	68	12 GRN	J9-G	J10-G
W3-27	6	12 BARE	J9-G	BOX GND
W3-28	68	12 GRN	J10-G	J11-G
W3-29	6	12 BARE	J10-G	BOX GND
W3-30	68	12 GRN	J11-G	J12-G
W3-31	6	12 BARE	J11-G	BOX GND
W3-32	6	12 BARE	J12-G	BOX GND
W4-1	36	2 BLK	J1-A	MAIN CB-A
W4-2	36	2 RED	J1-B	MAIN CB-C
W4-3	36	2 BLU	J1-C	MAIN CB-E
W4-4	52	2 WHT	J1-N	NEUT
W4-5	36	6 GRN	J1-G1	GND
W4-6	36	6 GRN	J1-G2	GND
W4-7	36	6 GRN	J1-G3	GND
W4-8	36	6 GRN	J1-G4	GND
W4-9	36	6 GRN	E1	E2
W5-1	36	4 BLK	J2-A	CB1-B
W5-2	36	4 RED	J2-B	CB1-D
W5-3	36	4 BLU	J2-C	CB1-F
W5-4	52	4 WHT	J2-N	NEUT
W5-5	36	6 GRN	J2-G	GND
W6-1	340	4 BLK	J13-A	CB4-B
W6-2	340	4 RED	J13-B	CB4-D
W6-3	340	4 BLU	J13-C	CB4-F
W6-4	340	4 WHT	J13-N	NEUT
W6-5	340	6 GRN	J13-G	GND

4-42. WIRE LIST FOR 100 AMP SERVICE

Wire No	Inch Long	Size Awg And Color	From	To
W1-1	18	12 RED	E3	E7
W1-2	18	12 RED	E4	E8
W1-3	18	12 RED	E5	E9
W1-4	18	12 RED	E6	E10
W2-1	8	12 RED	CB6-B	S1-F0
W2-2	88	12 RED	CB6-B	S2-C
W2-3	90	12 RED	S1-LO	S3-1
W2-4	87	12 RED	S2-NO	S1-LO
W2-5	27	12 RED	S2-NO	S4-1
W2-6	81	12 RED	S3-2	DS1
W2-7	184	12 RED	S4-2	DS2-B
W2-8	90	12 RED	DS2-B	DS3-B
W2-9	90	12 RED	DS3-B	DS4-B
W2-10	78	12 WHT	DS1	NEUT
W2-11	97	12 WHT	DS2-N	NEUT
W2-12	90	12 WHT	DS2-N	DS3-N
W2-13	90	12 WHT	DS3-N	DS4-N
W2-14	97	12 GRN	DS2-G	GND
W2-15	90	12 GRN	DS2-G	DS3-G
W2-16	90	12 GRN	DS3-G	DS4-0
W2-17	78	12 GRN	DS1-G	GND
W2-18	20	12 BLU	CB8-B	J3-C
W2-19	20	12 BLU	CB8-B	J4-C
W2-20	20	12 WHT	J3-W	NEUT
W2-21	20	12 WHT	J4-W	NEUT
W2-22	20	12 GRN	J3-G	GND
W2-23	20	12 GRN	J4-G	GND
W2-24	30	12 WHT	S1-NEUT	NEUT
W2-25	10	12 BARE	S2-GND	DS1-BOX GND
W2-26	24	12 GRN	DS1-G	S4-BOX GND
W3-1	52	12 BLK	CB3-B	J5-A
W3-2	68	12 BLK	J5-A	J6-A
W3-3	68	12 BLK	J6-A	J7-A
W3-4	68	12 BLK	J7-A	J8-A
W3-5	52	12 WHT	J5-N	NEUT
W3-6	68	12 WHT	J5-N	J6-N

4-42. (Cont)

Wire No	Inch Long	Size Awg And Color	From	To
W3-7	68	12 WHT	J6-N	J7-N
W3-8	68	12 WHT	J7-N	J8-N
W3-9	52	12 GRN	J5-G	GND
W3-10	68	12 GRN	J5-G	J6-G
W3-11	6	12 BARE	J5-G	BOX GND
W3-12	68	12 GRN	J6-G	J7-G
W3-13	6	12 BARE	J6-G	BOX GND
W3-14	68	12 GRN	J7-G	J8-G
W3-15	6	12 BARE	J7-G	BOX GND
W3-16	6	12 BARE	J8-G	BOX GND
W3-17	123	12 RED	CB5-B	J9-B
W3-18	68	12 RED	J9-B	J10-B
W3-19	68	12 RED	J10-B	J11-B
W3-20	68	12 RED	J11-B	J12-B
W3-21	123	12 WHT	J9-N	NEUT
W3-22	68	12 WHT	J9-N	J10-N
W3-23	68	12 WHT	J10-N	J11-N
W3-24	68	12 WHT	J11-N	J12-N
W3-25	123	12 GRN	J9-G	GND
W3-26	68	12 GRN	J9-G	J10-G
W3-27	6	12 BARE	J9-G	BOX GND
W3-28	68	12 GRN	J10-G	J11-G
W3-29	6	12 BARE	J10-G	BOX GND
W3-30	68	12 GRN	J11-G	J12-G
W3-31	6	12 BARE	J11-G	BOX GND
W3-32	6	12 BARE	J12-G	BOX GND
W4-1	36	2 BLK	J1-A	MAIN CB-A
W4-2	36	2 RED	J1-B	MAIN CB-C
W4-3	36	2 BLU	J1-C	MAIN CB-E
W4-4	52	2 WHT	J1-N	NEUT
W4-5	36	6 GRN	J1-G1	GND
W4-6	36	6 GRN	J1-G2	GND
W4-7	36	6 GRN	J1-G3	GND
W4-8	36	6 GRN	J1-G4	GND
W4-9	36	6 GRN	E1	E2
W5-1	36	4 BLK	J2-A	CB1-B
W5-2	36	4 RED	J2-B	CB1-D
W5-3	36	4 BLU	J2-C	CB1-F
W5-4	52	4 WHT	J2-N	NEUT
W5-5	36	6 GRN	J2-G	GND
W6-1	340	4 BLK	J13-A	CB4-B
W6-2	340	4 RED	J13-B	CB4-D
W6-3	340	4 BLU	J13-C	CB4-F
W6-4	340	4 WHT	J13-N	NEUT
W6-5	340	6 GRN	J13-G	GND

Section IV. PREPARATION FOR STORAGE AND SHIPMENT

4-43. PREPARATION FOR STORAGE AND SHIPMENT.

The following steps describe procedures for storing or shipping the shelter.

- a. Inspection. Inspect the shelter for the following:
 - (1) Make sure all circuit breakers and switches in OFF position.
 - (2) Make sure circuit breaker panel door is closed.
 - (3) Make sure equipment container is strapped down to shelter floor.
 - (4) Make sure caps are secured on power entry panel receptacles and binding posts are tightened.
 - (5) Make sure all lights and jacks are secured in their stowage positions.
 - (6) Make sure all doors are securely closed.
- b. Packing- Be sure all components are clean and dry before packing.

CAUTION

Use care when transporting or storing shelter to prevent damage to shelter.

- c. Care and Storage. Store shelter in a dry area or a designated supply facility. If stored outside in humid conditions, check quarterly for dampness inside the shelter.

CHAPTER 5
DIRECT SUPPORT MAINTENANCE INSTRUCTIONS

5-1. GENERAL. This chapter provides maintenance procedures for direct support personnel and consists of the following:

- a. Roof panel replacement (paragraph 5-2).
- b. Corner post and ISO fitting assembly replacement and repair (paragraph 5-3).

5-2. ROOF PANEL

This task covers:

- a. Removal
- b. Installation

INITIAL SETUP

Special Tools

Top lifting container lift sling,
Appendix D

Standard Tools

General mechanics tool kit
Electrical tool kit

Personnel - 6

1 Electrician

Materials

Sealing compound, Item 19,
Appendix E
Solvent, Item 20, Appendix E

REMOVAL

1. Disconnect site power.
2. Set main circuit breaker and circuit breaker CB6 to off position.
3. Remove roof area ceiling lights. (Refer to para 4-11.)
4. Remove raceway assembly. (Refer to para 4-16.1).
5. Remove bolts (1), lockwashers (2), and washers (3) securing fixed roof to upper ISO fittings (4).
6. Remove bolts (5), lockwashers (6), and washers (7) securing fixed roof (8), to front endwall and sidewall.
7. Remove bolts (9), lockwashers (10), and washers (11) securing roof to rear endwall.

WARNING

Methylethylketone is flammable and toxic and shall be used in a well-ventilated area away from sparks or open flame. Gloves should be worn during use.

5-2. (cont)

8. Apply solvent to sealed interface areas between roof, sidewall, and endwalls.

CAUTION

Do not damage roof panel.

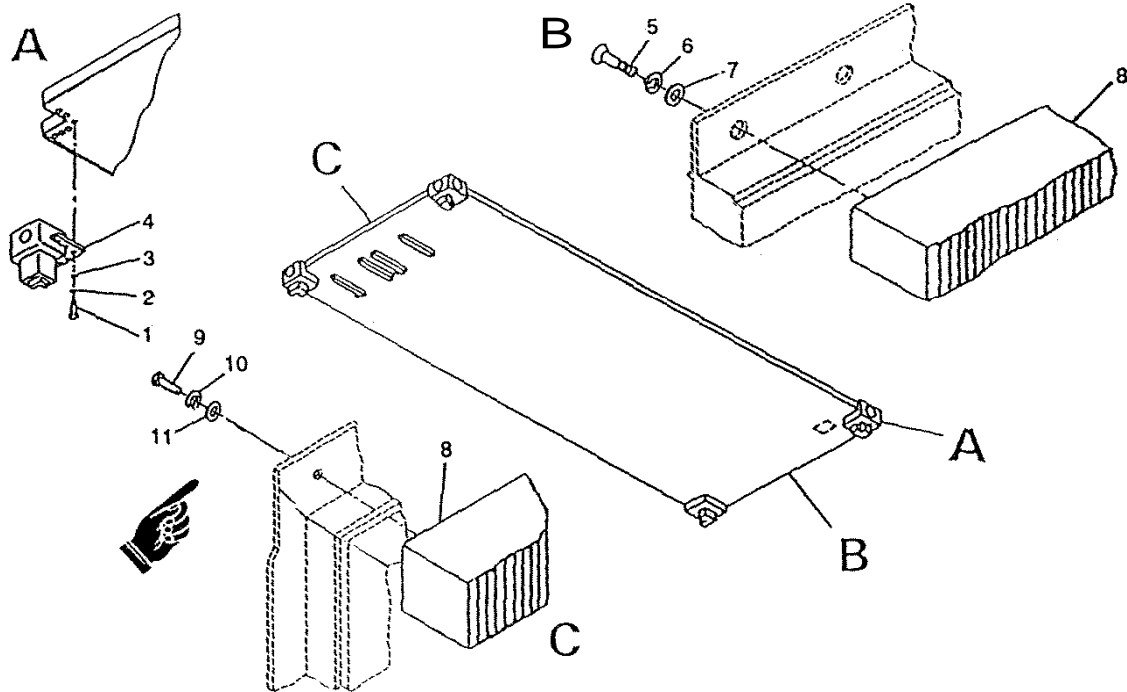

9. Push roof (8), up from endwalls to gain clearance for sling.
10. Slide web straps of lifting sling under roof and attach to crane or equivalent lifting device.
11. Remove roof (8).

CLEANING, INSPECTION

1. Clean mating surfaces.
2. Inspect mating surfaces for corrosion and damage.

INSTALLATION

1. Apply sealing compound to mating areas of roof with endwalls and sidewalls.
2. Position roof over shelter with crane (or equivalent lifting device) and a lifting sling with web straps.
3. Support roof and remove sling straps to allow roof to be supported by upper ISO fitting at corner posts.

4. Align mounting holes at ISO fittings.
5. Install bolts (1), lockwashers (2), and washers (3) securing fixed roof to upper ISO fittings (4).
6. Install bolts (9), lockwashers (10), and washers (11), securing roof (8) to front endwall.
7. Install bolts (5), lockwashers (6), and washers (7) securing roof (8) to rear endwall.
8. Install bolts (5), lockwashers (6), and washers (7) securing roof (8) to sidewalls.
9. Install ceiling lights. (Refer to para 4-11.)
10. Connect site power.
11. Set main and circuit breakers CB6 to ON position.

5-3. CORNER POST AND ISO FITTING ASSEMBLY

This task covers:

- | | |
|-------------------------|-----------------|
| a. Removal | d. Repair |
| b. Disassembly | e. Assembly |
| c. Cleaning, Inspection | f. Installation |

INITIAL SETUP

Special tools

Hand blind riveter, Appendix B,
Item 2

Standard tools

General mechanics tool kit
Personnel – 2

REMOVAL

NOTE

Remove shelter components as required for individual corner post replacement.

1. Remove front endwall panel in accordance with paragraph 4-19.
2. Remove rear endwall panel in accordance with paragraph 4-20.

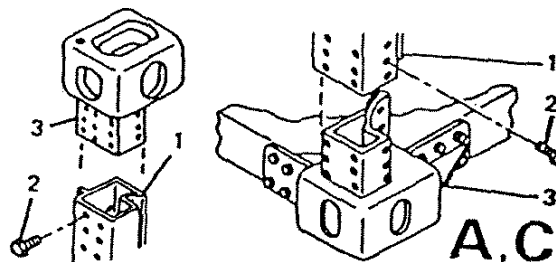

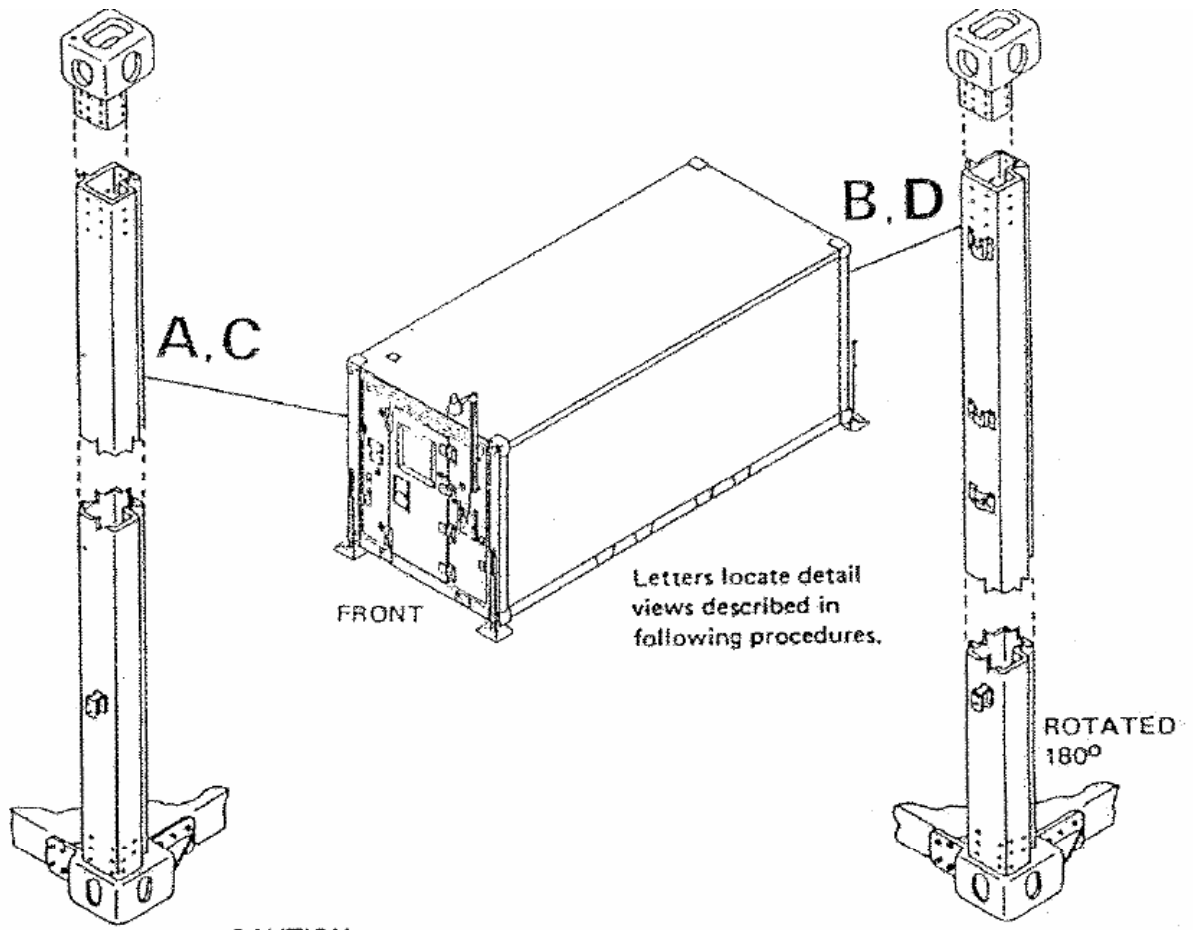

CAUTION

Support free corner of affected sidewall with web straps around girth of shelter.

3. Remove roof panel in accordance with paragraph 5-2.
4. Support corner post (1) and remove bolts (2) securing post to upper and lower ISO fittings (3).

DISASSEMBLY

1. Remove screws (4) and remove jack support fitting (5).
2. Drill out rivets (6) and remove light bracket (7). (Refer to para 4-26.)
3. Remove screws (8), lockwashers (9), and washers (10) and remove door holder (11).

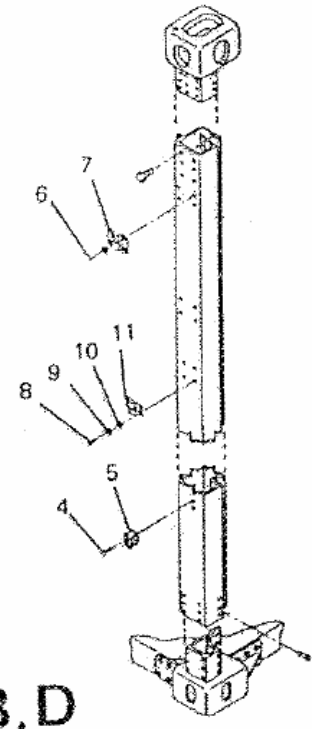

5-3. (cont)

CLEANING, INSPECTION

1. Wipe post and component surfaces.
2. Inspect mounting surfaces for corrosion and damage.
3. Inspect for and replace if necessary.
 - a. Missing or damaged components.
 - b. Corrosion or paint damage.

REPAIR

Corrosion or paint damage. (Refer to para 4-37.)

ASSEMBLY

1. Position door holder (11) and install washers (10), lockwashers (9) and screws (8).
2. Position light bracket (7) and install rivets (6). (Refer to para 4-26.)
3. Position jack support fitting (5) and install screws (4).

INSTALLATION

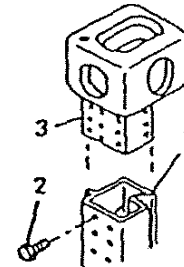
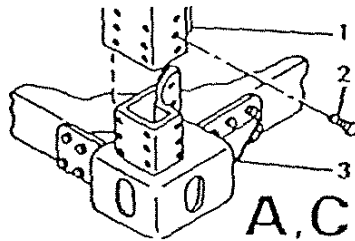

1. Position and support corner post (1) on upper and lower ISO fitting (3) and install bolts (2).
2. Install roof panel in accordance with paragraph 5-2.
3. Install rear endwall panel in accordance with paragraph 4-20.
4. Install front endwall panel in accordance with paragraph 4-19.

PAGES 5-6 THROUGH 5-10 ARE DELETED

CHAPTER 6

GENERAL SUPPORT MAINTENANCE INSTRUCTIONS

6-1. GENERAL. This chapter consists of maintenance procedures for general support personnel. These procedures are limited to the floor panel replacement (paragraph 6-2).

6-2. FLOOR PANEL/BASE FRAME

This task covers:

- | | |
|-------------------------|-----------------|
| a. Removal | d. Assembly |
| h. Disassembly | e. Installation |
| c. Cleaning, Inspection | |

INITIAL SETUP

Special tools

- Hand blind riveter, Appendix B, Item 2
- Blind bolt removal tool kit, Appendix B, Item 11
- Installation tool, Appendix B, Item 13
- Bottom lifting container lift sling, Appendix D

Standard Tools

- General mechanics tool kit

Personnel - 4

Materials

- Adhesive, Item 3, Appendix E
- Sealing compound, Item 19, Appendix E
- Solvent, Item 20, Appendix E

REMOVAL

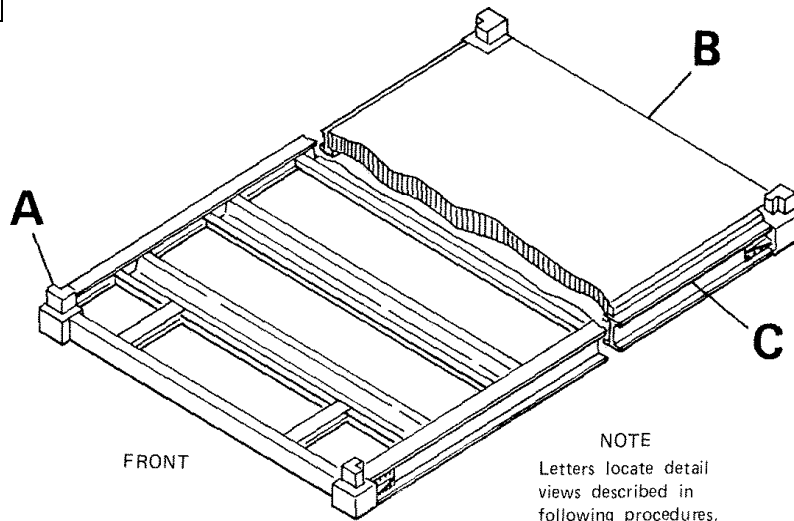

6-2. (cont)

1. Remove bolts (1) securing corner posts (2) to lower ISO fittings (3).
2. Remove bolts (4), lockwashers (5), and washers (6) securing front endwall to floor.

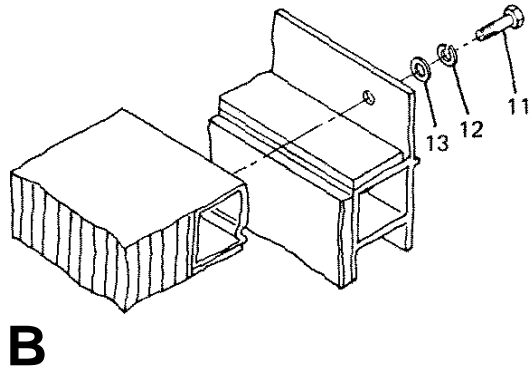
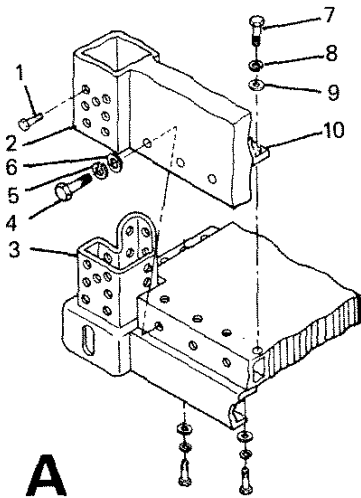

3. Remove screws (7), lockwashers (8), and washers (9) securing reinforcement angles (10) to floor.
4. Remove bolts (11), lockwashers (12), and washers (13) securing rear endwall to floor.

WARNING

Methylethylketone is flammable and toxic and shall be used in a well-ventilated area away from sparks or open flame. Gloves should be worn during use.

5. Apply solvent to sealed interface areas of floor with sidewalls and endwalls.
6. Secure web straps around shelter body.
7. Attach lifting sling to upper ISO fittings.
8. Lift shelter body away from floor and set in level position on blocks.

6-2. (cont)

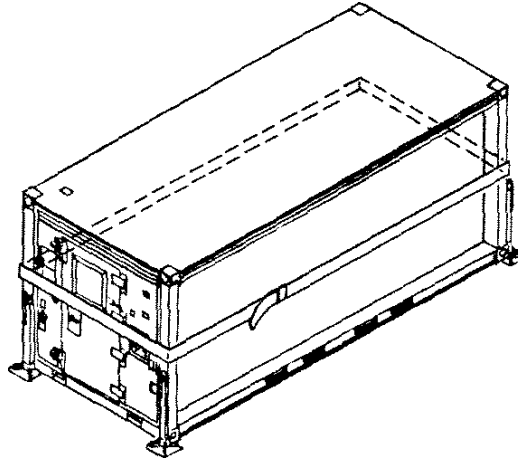

9. Using blind bolt removal tool kit, remove rivets (14) and support angle assembly (15). (Refer to 4-26.)

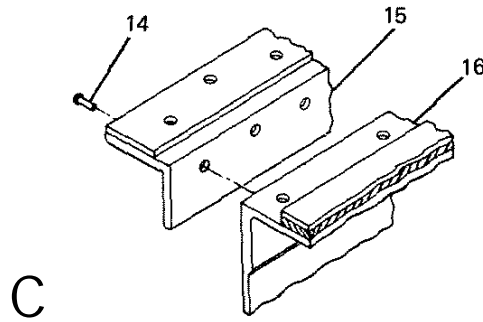

DISASSEMBLY

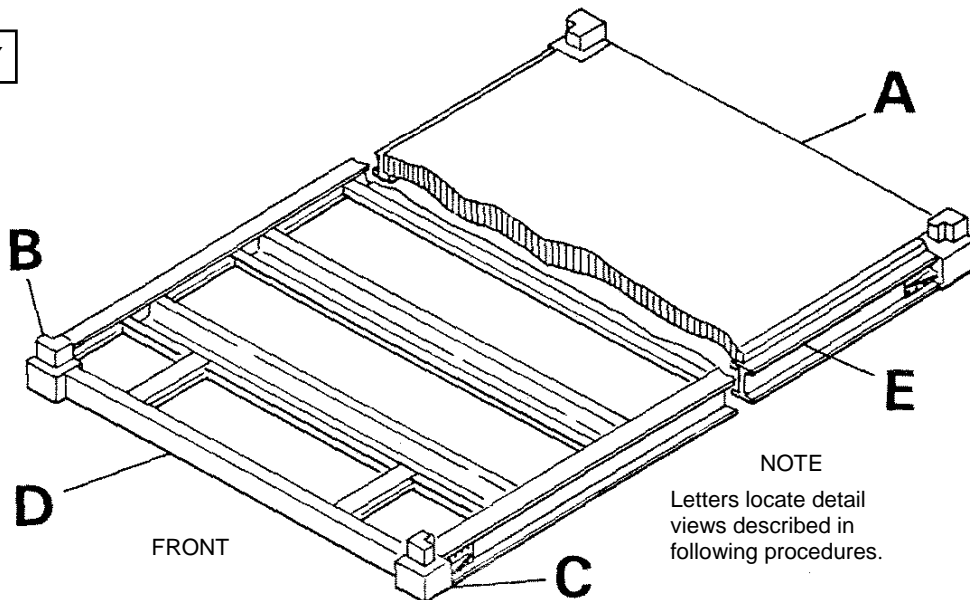

6-2. (cont)

1. Remove screws (1), lockwashers (2), and washers (3) securing base frame (4) to floor panel (5).
2. Remove nuts (6), lockwashers (7), washers (8), and bolts (9) securing lower ISO fittings (10 and 11) to base frame (4).

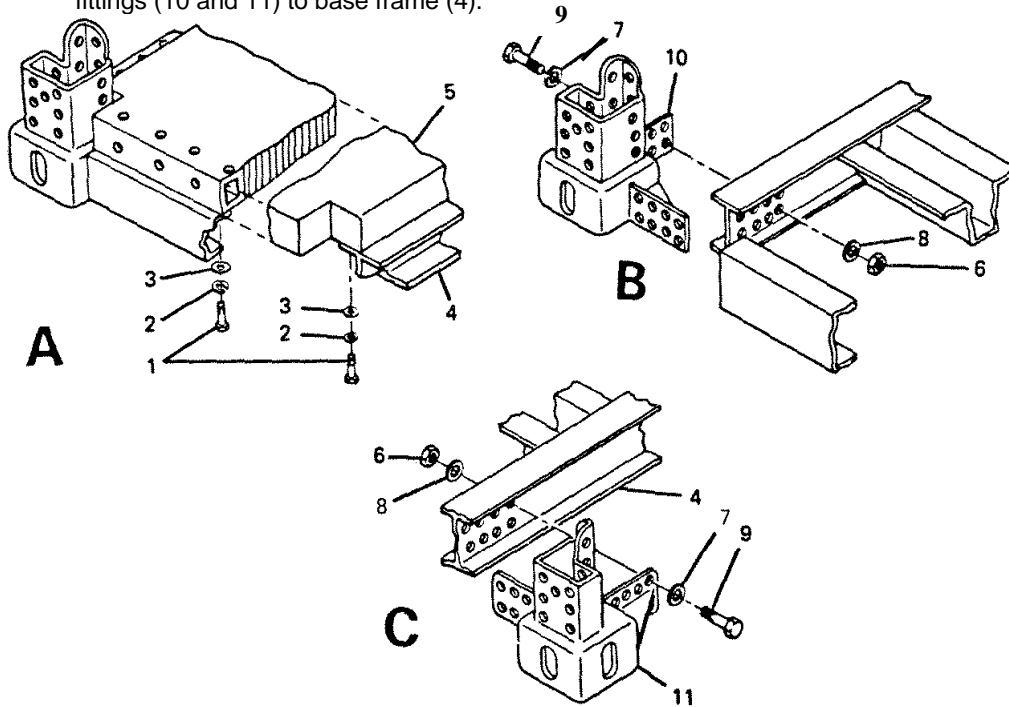

CLEANING, INSPECTION

1. Wipe panel and component surfaces.
2. Inspect mounting surfaces for corrosion and damage.
3. Inspect for and replace if necessary:
 - a. Missing or damaged components.
 - b. Corrosion or paint damage.

REPAIR

1. Panel skin damage. (Refer to paragraphs 4-25 through 4-36.)
2. Corrosion or paint damage. (Refer to 4-37.)

6-2. (cont)

ASSEMBLY

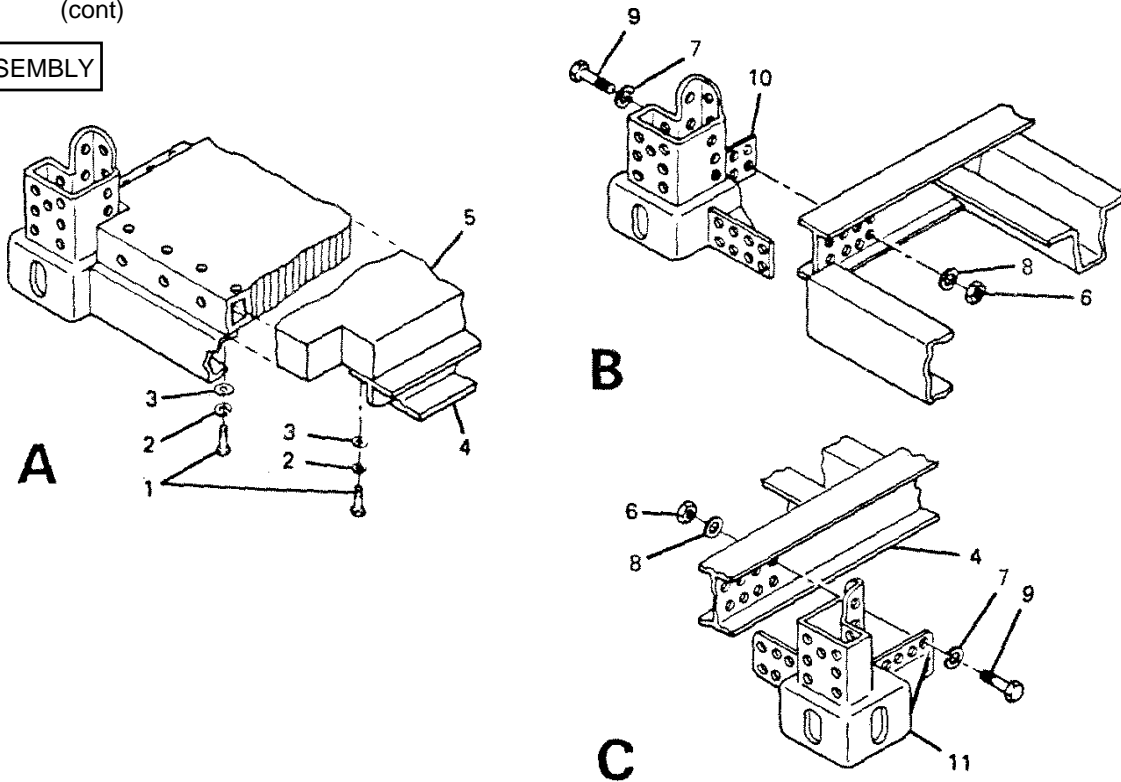

1. Position lower ISO fittings (10 and 11) on base frame (4) and install bolts (9), washers (8), lockwashers (7), and nuts (6).
2. Position base frame (4) on floor panel (5) and install washers (3), lockwashers (2), and screws (1).

INSTALLATION

NOTE

Turn floor over with base frame down.

1. Using installation tool, assemble support angle assembly (15) to base frame (16) with rivets (14). (Refer to 4-26.)
2. Secure web straps around shelter body.
3. Attach lifting sling to upper ISO fitting.
4. Lift shelter body and lower to position above floor.
5. Apply sealing compound to interface areas of floor and endwalls.
6. Lower shelter body carefully to fixed floor.

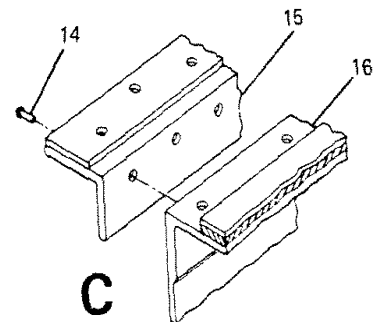

6-2. (cont)

7. Ensure that corner posts engage lower ISO fittings at all four corners.
8. Secure rear endwall to floor with washers (13), lockwashers (12), and bolts (11).
9. Secure front endwall to floor with washers (6), lockwashers (5), and bolts (4).
10. Secure reinforcement angles (10) to floor with washers (9), lockwashers (8) and screws (7).
11. Secure corner posts (2) to lower ISO fittings (3) with bolt (1).

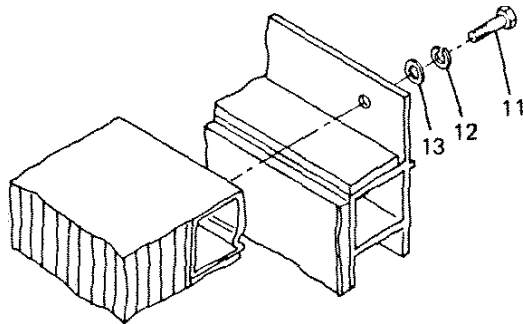
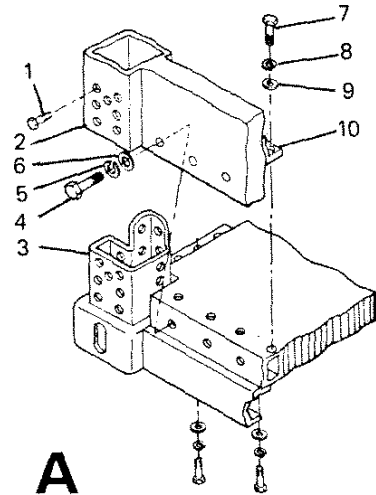
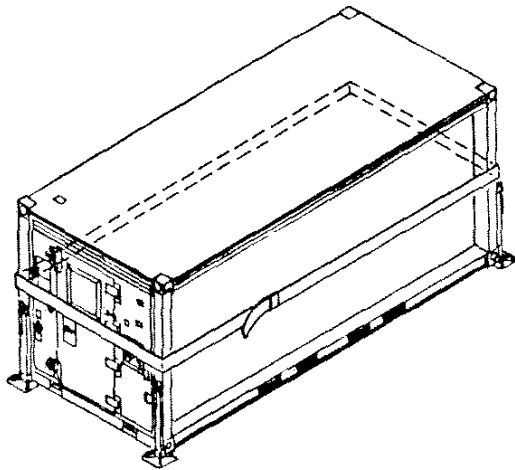

B

APPENDIX A
REFERENCES

A-1. SCOPE

This appendix lists all forms, field manuals, technical manuals and miscellaneous publications referenced in this manual.

A-2. FORMS

Recommended Changes to Publications on Blank Forms	DA-2028
Quality Deficiency Report	SF-368
Transportation Discrepancy Report	SF-361

A-3. FIELD MANUALS

Destruction of Equipment to Prevent Enemy Use	TM 750-244-3
---	--------------

A-4. TECHNICAL MANUALS

Repair Parts and Special Tools List	TM 10-5411-202-24P
The Army Maintenance Management System	DA Pamphlet 738-750
Dollyset Model No. M832	TM 9-2330-275-14&P
Dollyset Model No. M1022	TM 9-2330-379-14&P

APPENDIX B

MAINTENANCE ALLOCATION CHART

Section I. INTRODUCTION**The Army Maintenance System MAC**

This introduction provides a general explanation of all maintenance and repair functions authorized at the two maintenance levels under the Two-Level Maintenance System concept.

The MAC (immediately following the introduction) designates overall authority and responsibility for the performance of maintenance functions on the identified end item or component. The application of the maintenance functions to the end item or component shall be consistent with the capacities and capabilities of the designated maintenance levels, which are shown on the MAC in column (4) as:

Field - includes two columns, Unit maintenance and Direct Support maintenance. The Unit maintenance column is divided again into two more subcolumns, C for Operator or Crew and O for Unit maintenance.

Sustainment – includes two subcolumns, General Support (H) and Depot (D).

The tools and test equipment requirements (immediately following the MAC) list the tools and test equipment (both special tools and common tool sets) required for each maintenance function as referenced from the MAC.

The remarks (immediately following the tools and test equipment requirements) contain supplemental instructions and explanatory notes for a particular maintenance function.

Maintenance Functions

Maintenance functions are limited to and defined as follows:

1. Inspect. To determine the serviceability of an item by comparing its physical, mechanical, and/or electrical characteristics with established standards through examination (e.g., by sight, sound, or feel.) This includes scheduled inspection and gagings and evaluation of cannon tubes.
2. Test. To verify serviceability by measuring the mechanical, pneumatic, hydraulic, or electrical characteristics of an item and comparing those characteristics with prescribed standards on a scheduled basis, i.e., load testing of lift devices and hydrostatic testing of pressure hoses.
3. Service. Operations required periodically to keep an item in proper operating condition, e.g., to clean (includes decontaminate, when required), to preserve, to drain, to paint, or to replenish fuel, lubricants, chemical fluids, or gases. This includes scheduled exercising and purging of recoil mechanisms. The following are examples of service functions:
 - a. Unpack. To remove from packing box for service or when required for the performance of maintenance operations.
 - b. Repack. To return item to packing box after service and other maintenance operations.
 - c. Clean. To rid the item of contamination.

- d. Touch up. To spot paint scratched or blistered surfaces.
 - e. Mark. To restore obliterated identification.
4. Adjust. To maintain or regulate, within prescribed limits, by bringing into proper or position, or by setting the operating characteristics to specified parameters.
 5. Align. To adjust specified variable elements of an item to bring about optimum or desired performance.
 6. Calibrate. To determine and cause corrections to be made or to be adjusted on instruments of test, measuring, and diagnostic equipment used in precision measurement. Consists of comparisons of two instruments, one of which is a certified standard of known accuracy, to detect and adjust any discrepancy in the accuracy of the instrument being compared.
 7. Remove/Install. To remove and install the same item when required to perform service or other maintenance functions. Install may be the act of emplacing, seating, or fixing into position a spare, repair part, or module (component or assembly) in a manner to allow the proper functioning of an equipment or system.
 8. Paint. To prepare and spray color coats of paint so that the ammunition can be identified and protected. The color indicating primary use is applied, preferably, to the entire exterior surface as the background color of the item. Other markings are to be repainted as original so as to retain proper ammunition identification.
 9. Replace. To remove an unserviceable item and install a serviceable counterpart in its place. "Replace" is authorized by the MAC and assigned maintenance level is shown as the third position code of the Source, Maintenance and Recoverability (SMR) code.
 10. Repair. The application of maintenance services, including fault location/troubleshooting, removal/installation, disassembly/assembly procedures and maintenance actions to identify troubles and restore serviceability to an item by correcting specific damage, fault, malfunction, or failure in a part, subassembly, module (component or assembly), end item, or system.

NOTE

The following definitions are applicable to the "repair" maintenance function:

Services. Inspect, test, service, adjust, align, calibrate, and/or replace.

Fault location/troubleshooting. The process of investigating and detecting the cause of equipment malfunctioning; the act of isolating a fault within a system or Unit Under Test (UUT).

Disassembly/assembly. The step-by-step breakdown (taking apart) of a spare/functional group coded item to the level of its least component, that is assigned an SMR code for the level of maintenance under consideration (i.e.. identified as maintenance significant).

Actions. Welding, grinding, riveting, straightening, facing, machining, and/or resurfacing.

11. Overhaul. That maintenance effort (service/action) prescribed to restore an item to a completely serviceable/operational condition as required by maintenance standards in appropriate technical publications. Overhaul is normally the highest degree of maintenance performed by the Army. Overhaul does not normally return an item to like new condition.
12. Rebuild. Consists of those services/actions necessary for the restoration of unserviceable equipment to a like new condition in accordance with original manufacturing standards. Rebuild is the highest degree of material maintenance applied to Army equipment. The rebuild operation includes the act of returning to zero those age measurements (e.g., hours/miles) considered in classifying Army equipment/components.

B-3. Explanation of Columns in the MAC, Section II

Column (1) Group Number. Column (1) lists Functional Group Code (FGC) numbers, the purpose of which is to identify maintenance significant components, assemblies, subassemblies, and modules with the Next Higher Assembly (NHA).

Column (2) Component/Assembly. Column (2) contains the item names of components, assemblies, subassemblies, and modules for which maintenance is authorized.

Column (3) Maintenance Function. Column (3) lists the functions to be performed on the item listed in column (2). (For a detailed explanation of these functions refer to "Maintenance Functions" outlined above).

Column (4) Maintenance Level. Column (4) specifies each level of maintenance authorized to perform each function listed in column (3), by indicating work time required (expressed as manhours in whole hours or decimals) in the appropriate subcolumn. This work time figure represents the active time required to perform that maintenance function at the indicated level of maintenance. If the number or complexity of the tasks within the listed maintenance function varies at different maintenance levels, appropriate work time figures are to be shown for each level. The work time figure represents the average time required to restore an item (assembly, subassembly, component, module, end item, or system) to a serviceable condition under typical field operating conditions. This time includes preparation time (including any necessary disassembly/assembly time), troubleshooting/fault location time, and quality assurance time in addition to the time required to perform the specific tasks identified for the maintenance functions authorized in the MAC. The symbol designations for the various maintenance levels are as follows:

Field:

- C Operator or Crew maintenance
- O Unit maintenance
- F Direct Support maintenance

Sustainment:

- L Specialized Repair Activity
- H General Support maintenance
- D Depot maintenance

NOTE

The "L" maintenance level is not included in column (4) of the MAC. Functions to this level of maintenance are identified by work time figure in the "H" column of column (4), and an associated reference code is used in the REMARKS column (6). This code is keyed to the remarks and the SRA complete repair application is explained there.

Column (5) Tools and Equipment Reference Code. Column (5) specifies, by code, those common tool sets (not individual tools), common Test, Measurement and Diagnostic Equipment (TMDE), and special tools, special TMDE, and support special equipment required to perform the designated function. Codes are keyed to the entries in the tools and test equipment table.

Column (6) Remarks Code. When applicable, this column contains a letter code, in alphabetic order, which is keyed to the remarks table entries.

B-3. Explanation of Columns in the Tools and Test Equipment Requirements, Section III

Column (1) - Tool or Test Equipment Reference Code. The tool or test equipment reference code correlates with a code used in column (5) of the MAC.

Column (2) - Maintenance Level. The lowest level of maintenance authorized to use the tool or test equipment.

Column (3) – Nomenclature. Name or identification of the tool or test equipment.

Column (4) – National Stock Number (NSN). The NSN of the tool or test equipment.

Column (5) – Tool Number. The manufacturer's part number.

B-4. Explanation of Columns in Remarks, Section IV

Column (1) – Remarks Code. The code recorded in column (6) of the MAC.

Column (2) – Remarks. This column lists information pertinent to the maintenance function being performed as indicated in the MAC.

**Section II MAINTENANCE ALLOCATION CHART
FOR
SHELTER, TACTICAL, NONEXPANDABLE**

(1) GROUP NUMBER	(2) COMPONENT/ ASSEMBLY	(3) MAINTENANCE FUNCTION	(4) MAINTENANCE LEVEL					(5) TOOL AND EQUIPMENT REFERENCE CODE	(6) REMARKS CODE
			Field			Sustainment			
			UNIT		DIRECT SUPPORT	GENERAL SUPPORT	DEPOT		
			C	O	F	H	D		
01	ELECTRICAL SYSTEM								
	CIRCUIT BREAKER PANEL ASSEMBLY	Inspect	0.2						
		Test		0.2				4	
		Replace		1.0				1	
	PANEL WIRING	Repair		0.5				1	
		Inspect	0.2						
		Test		0.2				4	
	PANEL WIRING	Replace		0.5				1	
		Repair		0.5				1	
		Inspect	0.2						
	LIGHT SWITCHES	Test		0.2				4	
		Replace		0.3				1	
	CIRCUIT BREAKERS	Inspect	0.2						
		Test		0.1				4	
Replace			0.2				1		
POWER ENTRY PANEL ASSEMBLY	Inspect	0.2					4		
	Test		0.2				1,2		
	Replace		1.0				1,2,12		
	Repair		0.5						
RECEPTACLES	Inspect	0.1					4		
	Test		0.2				1,12		
	Replace		0.3				1		
	Repair		0.3						
TERMINALS/ CONNECTORS	Inspect	0.2					1		
	Replace		0.3				1		
	Repair		0.3						
AREA LIGHT ASSEMBLY	Inspect	0.1					4		
	Test		0.1				1		
	Replace	0.1					1,2		
	Repair		0.5						
INCANDESCENT LIGHT ASSEMBLY	Inspect	0.1					4		
	Test		0.1				1		
	Replace		0.5				1		
	Repair		0.3				1		

**Section II. MAINTENANCE ALLOCATION CHART
F O R
SHELTER, TACTICAL, NONEXPANDABLE - continued**

(1) GROUP NUMBER	(2) COMPONENT/ ASSEMBLY	(3) MAINTENANCE FUNCTION	(4) MAINTENANCE LEVEL					(5) TOOL AND EQUIPMENT REFERENCE CODE	(6) REMARKS CODE
			Field		Sustainment				
			UNIT	DIRECT SUPPORT	GENERAL SUPPORT	DEPOT			
			C	O	F	H	D		
04	CEILING LIGHTS	Inspect Test Replace Repair	0.1	0.1 0.2 0.5				4 1 1,2	
	RECETPACLES OUTLETS	Inspect Test Replace Repair	0.1	0.1 0.3 0.2				4 9 1	
	SWITCH,WALL	Inspect Replace	0.1	0.3				1	
	SWITCH, BLACKOUT, DOOR ACTIVATED	Inspect Replace Repair Adjust	0.1	1.5 0.5 0.2				1 1 1	
	FIXED PANEL ASSEMBLIES								
	ENDWALL PANEL FRONT	Inspect Replace Repair	0.2	4.0 2.0				1 1,2	
	LEVEL ASSEMBLY	Inspect Replace Repair	0.1	0.5 0.4				2 1	
	STEP, FOLDING	Inspect Replace Repair	0.1	0.2 0.2				1 1	
	ENDWALL PANEL, REAR	Inspect Replace Repair	0.2	3.0 2.0				1 1,2	
	ECU INTAKE PANEL	Inspect Replace Repair	0.1 0.1	0.5				1 1,2,3	

**Section II. MAINTENANCE ALLOCATION CHART
FOR
SHELTER, TACTICAL, NONEXPANDABLE - continued**

(1) GROUP NUMBER	(2) COMPONENT/ ASSEMBLY	(3) MAINTENANCE FUNCTION	(4) MAINTENANCE LEVEL					(5) TOOL AND EQUIPMENT REFERENCE CODE	(6) REMARKS CODE	
			Field		Sustainment					
			UNIT		DIRECT SUPPORT	GENERAL SUPPORT	DEPOT			
			C	O	F	H	D			
05	ECU RETURN PANEL	Inspect Replace Repair	0.1 0.1	0.5				1 1,3		
	CLOSEOUT PANEL	Inspect Replace Repair	0.1 0.1	0.5				1 1,3		
	SIDEWALL PANEL	Inspect Replace Repair	0.3	4.0 3.0				1 1,2		
	ROOF PANEL	Inspect Replace Repair	0.3	6.0 3.0				1,6,7 1,2		
	STOWAGE BRACKETS	Inspect Replace Repair	0.1	0.2 0.2				1 1		
	FLOOR PANEL/BASE FRAME	Inspect Replace Repair	0.2	3.0	12.0			1,2,7,8 1,13,14		
	FRAME ASSEMBLY									
06	CORNER POST AND ISO FITTING ASSEMBLY	Inspect Replace Repair	0.2	10.0 2.0				1,2 1,2		
	MICELLANEOUS COMPONENTS									
	EQUIPMENT CONTAINER	Inspect Replace Repair	0.2	0.2 0.5				1		
	STORM CONFIGURATION COMPONENTS	Inspect Replace	0.1 0.2					1		

**Section III. TOOLS AND TEST EQUIPMENT
FOR
SHELTER, TACTICAL, NONEXPANDABLE**

(1) TOOL OR TEST EQUIPMENT REFERENCE CODE	(2) MAINTENANCE LEVEL	(3) NOMENCLATURE	(4) NATIONAL STOCK NUMBER	(5) TOOL NUMBER
1	C,O,F,H	Tool Kit, General Mechanics	5180-00-177-7033	
2	O,F,H	Riveter, Blind Hand	5120-00-017-2849	
3	C	Installation Tool		FSCM 08524
4	O	Multimeter	6625-00-999-6282	
5	O	Tool Kit, Electrical	5180-00-876-9336	
6	O	Drill, Electric, Portable 1¼ inch cap	5130-00-204-2778	
7	O	Fastener Header (10- 32,1/4-28)		FSCM 03481 C845
8	O	Fastener Header (5/16- 24,3/8-24)		FSCM 03481 C-722
9	O	Wrench, Box End or Adjustable		
10	O	Climping Tool		FSCM 56501 TBM5
11	O	Tool Kit, Blind Bolt Removal		FSCM 5650 105-60
12	O	Tool Kit, Blind Bolt Removal		FSCM 17446 105-80
13	O	Installation Tool		FSCM 17446 115
14	O	Router, Electric, Portable	5130-00-990-4449	
15	O	Heat Lamp, Tripod Base		FSCM 39428 8439K11

**Section IV. REMARKS
FOR
SHELTER, TACTICAL NONEXPANDABLE**

(1) REMARKS CODE	(2) REMARKS
	Not Applicable.

APPENDIX C
COMPONENTS OF THE END ITEM LIST

Section I. INTRODUCTION

C-1. SCOPE

This appendix lists components of end item for the shelter to help you inventory items required for safe and efficient operation.

C-2. GENERAL

The Components of End Item List is provided in Section II. This listing is for informational purposes only, and is not authority to requisition replacements. These items are part of the end item, but are removed and separately packaged for transportation or shipment. As part of the end item, these items must be with the end item whenever it is issued or transferred between property accounts. Illustrations are furnished to assist you in identifying the items.

C-3. EXPLANATION OF COLUMNS IN SECTION II

The following provides an explanation of columns found in the tabular listings:

- a. Column (1) - Illustration Number (Illus Number). This column indicates the number of the illustration in which the item is shown.
- b. Column (2) - National Stock Number. Indicates the National stock number assigned to the item and will be used for requisitioning purposes.
- c. Column (3) - Description. Indicates the Federal item name and, if required, a minimum description to identify and locate the item. The last line for each item indicates the FSCM (in parentheses) followed by the part number.
- d. Column (4) - Unit of Measure (U/M). Indicates the measure used in performing the actual operational/maintenance function. This measure is expressed by a two-character alphabetical abbreviation (e.g., ea, in, pr).
- e. Column (5) - Quantity required (Qty rqr). Indicates the quantity of the item authorized to be used with/on the equipment.

Section II. COMPONENTS OF END ITEM

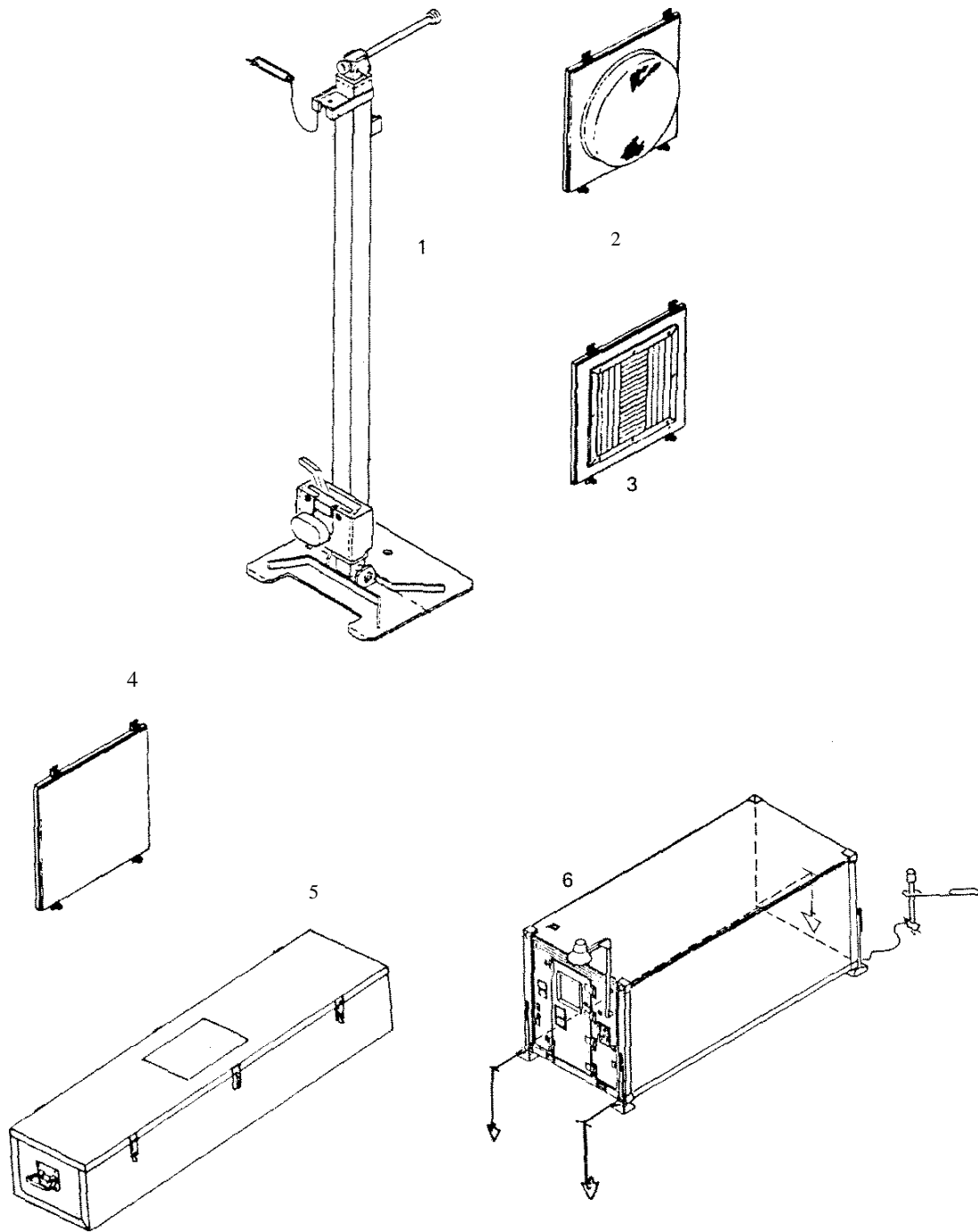

Section II. COMPONENTS OF END ITEM (cont)

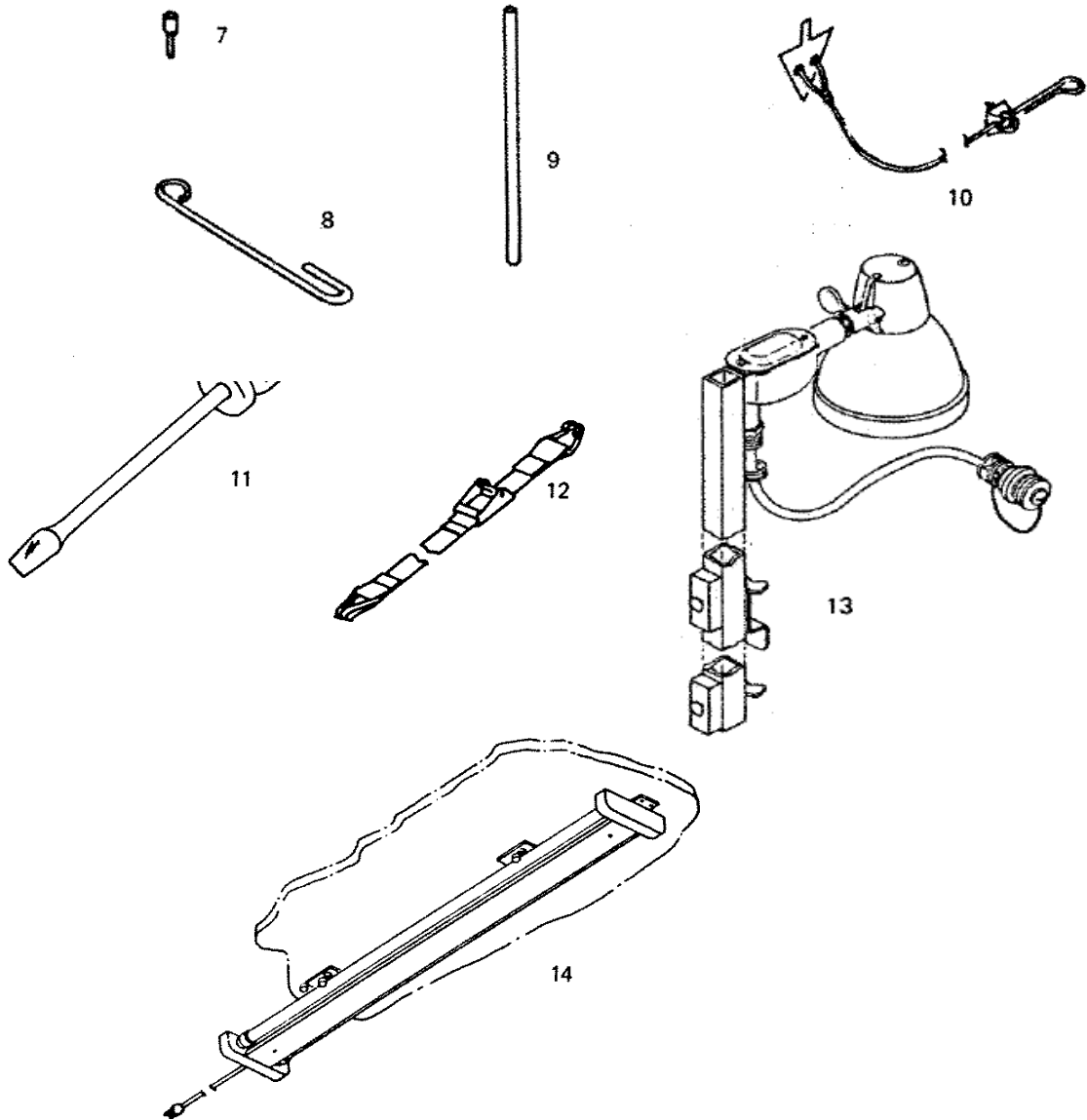

Section II. COMPONENTS OF END ITEM (cont)

(1) ILLUS NO.	(2) NATIONAL STOCK NUMBER	(3) DESCRIPTION FSCM AND PART NUMBER	(4) U/M	(5) QTY RQR
■ 1		JACK ASSEMBLY, INTERNATIONAL STANDARD FITTING (81337) 5-4-2866-1	EA	4
■ 2		PANEL ASSEMBLY, ECU RETURN (81337) 5-4-2857-1	EA	1
■ 3		PANEL ASSEMBLY, ECU INTAKE (81337) 5-4-2856-1	EA	1
■ 4		CLOSEOUT PANEL ASSEMBLY 21 X 21 (81337) 5-4-2853-1	EA	3
5		EQUIPMENT CONTAINER WITH CONTENTS (81337) 5-4-5096-1	EA	1
6		TIEDOWN INSTALLATION (81337) 5-4-4713-1	EA	1
7		DRIVE HEAD (81349) MIL – A- 3962 size 4 inch	EA	1
8		HOLDING HANDLE (81349) MIL – A- 3962 size 4, 6, 1c OR 8 1c INCH	EA	1
9		DRIVE ROD (81349) MIL – A- 3962 size 4 inch	EA	4
10		GROUND ANCHOR ASSEMBLY (81337) 5-4-2981-1	EA	1
11		SCREWDRIVER (81349) GGG-S-121 class 5 design A	EA	2
12		STRAP ASSEMBLY, TIEDOWN (81337) 5-4-4944-1	EA	1
13		LIGHT ASSEMBLY, EXTERIOR (81337) 5-4-2974-1	EA	1
14		LIGHT ASSEMBLY, REMOVABLE (81337) 5-4-2954-1	EA	3

**APPENDIX D
ADDITIONAL AUTHORIZATION LIST**

Section I. INTRODUCTION

D-1. SCOPE

This appendix lists additional items you are authorized for the support of the shelter.

D-2. GENERAL

This list identifies items that do not have to accompany the shelter and that do not have to be turned in with it. These items are all authorized to you by CTA, MTOE, TDA, or JTA.

D-3. EXPLANATION OF LISTING

National stock numbers, descriptions, and quantities are provided to help you identify and request the additional items you require to support this equipment. The items are listed in alphabetical sequence by item name under the type document (i.e., CTA, MTOE, TDA, or JTA) which authorizes the item(s) to you.

Section II. ADDITIONAL AUTHORIZATION LIST

(1) National Stock Number	(2) Description FSCM & Part Number	(3) U/M	(4) Qty Auth
	CONTAINER LIFT SLING, bottom lifting (65059) 74016B-20	EA	1
	CONTAINER LIFT SLING, top lifting (65059) 74016T-1A	EA	1
5975-00-878-3791	GROUND ROD ASSEMBLY	EA	1
5120-00-293-0887	SLEDGE HAMMER, 12 pound	EA	1
5120-01-013-1676	SLIDE HAMMER, ground	EA	1
6150-01-256-6301	FEEDER, PIG-TAIL, 4 ft lg, (97403) 13226E7019	EA	1
6150-01-247-4781	CABLE, SERVICE, 50 ft lg, (97403) 13226E7023-2	EA	1
6150-01-247-4779	CABLE, SERVICE, 100 ft lg, (97403) 13226E7023-1	EA	1
5210-00-239-0892	LEVEL, CARPENTER'S, 24-inch	EA	1
	PLATE, STRIKE (FOR OVERSEAS TRANSPORT) (81337) 5-4-6488	E A	1

APPENDIX E
EXPENDABLE SUPPLIES AND MATERIALS LIST

Section I. INTRODUCTION

E-1. SCOPE

Section II of this appendix lists expendable supplies and materials you will need to operate and maintain the shelter. These items are authorized to you by CTA 50-970, Expendable Items.

E-2. EXPLANATION OF COLUMNS IN SECTION II

- a. Column 1, Item Number. This number is assigned to the entry and is referenced in the narrative instructions to identify the material.
- b. Column 2, Level. This column identifies the lowest level of maintenance that requires the listed item.
 - C – Operator/Crew
 - O – Unit Maintenance
 - F – Direct Support Maintenance
 - H – General Support Maintenance
- c. Column 3, National Stock Number. This is the National stock number assigned to the item; use it to request or requisition the item.
- d. Column 4, Description. Indicates the Federal item name and, if required, a description to identify the item. The last line for each item indicates the Commercial and Government Entity (CAGE) in parenthesis followed by the part number.
- e. Column 5, Unit of Measure (U/M). Indicates the measure used in performing the actual maintenance function. This measure is expressed by a two character alphabetical abbreviation (e.g., ea, in, pr). If the unit of measure differs from the unit of issue, requisition the lowest unit of issue that will satisfy your requirements.

Section II. EXPENDABLE SUPPLIES AND MATERIALS LIST

(1) Item Number	(2) Level	(3) National Stock Number	(4) Description	(5) U/M
1			Adhesive (FE60268), (CAGE 92528)	
2		8040-00-865-8991	Adhesive, Silicon, Rubber, Aluminum	12
3		8040-00-142-9823	Adhesive, Silicon, Rubber, Black	oz can
4			Aluminum patch 0.040 in. thick x 12 x 12 in. (1.02 mm x 30.48 x 30.48 cm) (FED STD 200/8 5052-H34)	12
5			Cloth, Cotton, Wiping (FED STD DDD-R30)	oz tube
6			Coating system, epoxy-polyimide (MIL-C- 22751)	
7			Core, 3 in. thick x 12 x 12 ± 1 (76.2 mm x 30.48 x 30.48 ± 2.54 cm)	
8			ASTM-E-1091-86-TYPEIV	
9			Core, 2 ½ in. thick x 12 x 12 ± 1 (63.5 mm x 30.48 x 30.48 ± 2.54 cm)	
10			Core, 2 in. thick x 12 x 12 ± 1 (50.8 mm x 30.48 x 30.48 ± 2.54 cm)	
11		8415-00-634-5027	ASTM-E-1091-86-TYPEIV	
12			Core, 1 ½ in. thick x 12 x ± 1 (38.1 mm x 30.48 x 30.48 ± 2.54 cm)	
13			ASTM-E-1091-86-TYPEIV	
14			Gloves, White	
15			Grease, Automotive (MIL-G-10924)	
16			Rivet, Blind, Closed-end Sealing, 3/16 dia. 0.063 – 0.125 grip, P/N AD64H, CAGE No. 07707	
17			Rivet, Blind, Closed-end Sealing, 3/16 dia. 0.126 – 0.250 grip, P/N AD64H CAGE No. 07707	
18			Rivet, Blind, Closed-end Sealing, 3/16 dia. 0.251- 0.375 grip, P/N AD66H, CAGE No. 07707	
19			Rivet, Blind, Closed-end Sealing, 3/16 dia. 0.376 – 0.500 grip, P/N AD68H, CAGE No. 07707	
20			Rivet, Blind, Closed-end Sealing, 1/8 dia. 0.063 - 0.125 grip, P/N AD42H, CAGE No. 07707	
21			Rivet, Blind, Closed-end Sealing, 1/8 dia. 0.126-0.187 grip, P/N AD43H, CAGE No. 07707	
22			Rivet, Blind, Closed-end Sealing 1/8 dia. 0.188 - 0.250 grip, P/N AD44H CAGE No. 07707	
23			Rivet, Blind, Closed-end Sealing 1/8 dia. 0.251 – 0.312 grip, P/N AD45H, CAGE No. 07707	
24			Sandpaper, 120/220 GRIT (FED STD P-P- 101)	

Section II. EXPENDABLE SUPPLIES AND MATERIALS LIST (Cont)

(1) Item Number	(2) Level	(3) National Stock Number	(4) Description	(5) U/M
18 19 20			Sealant (MIL-S-22473) Sealing compound (PR1422) (MIL-S-8802) Solvent, Methylethylketone (TT-M-261)	64 oz cn
21 22		6180-00-687-8429 7510-00-266-7612	Stick, Stirring, Wood (FED STD A-A-1081) Tape, Pressure Sensitive 1 in. wide (2.54 cm)	
23		7510-00-266-7614	Tape, Pressure Sensitive 1.5 in. wide	
24			Grease, Silicone (Dow Corning 111 Compound). (CAGE 5D028)	
25 26 27		5411-01-352-8568	Aluminum Sheet 1/8 in. thick x 2 in. Square (3.2 min x 50.8 max) (QQA-200/8 5052-H-34) Lubricant, Spray (MIL-L-23398) Blind Nut Assy (CAGE 73197) (P/N BN532-524-122) Repair Kit, Shelter	EA

Subject	INDEX	Paragraph, Figure, Table Number
	A	
Administrative Storage		1-4
Area Light Assembly Replacement		3-4
Area Light Assembly		4-9
Area Light Installation		2-14
	B	
Blackout Switch		4-14
Blind Rivet Removal and Installation		4-26
	C	
Caulking Repaired Areas		4-36
Ceiling Light		4-11
Circuit Breaker Panel Assembly		4-7
Circuit Breaker Panel Controls and Indicators		2-2
Closeout, ECU Intake, and ECU Return Panels Replacement		3-5
Common Tools and Equipment		4-1
Container Lift Jack Assembly Replacement		3-6
Container Lift Jack Assembly		4-18
Deleted		
	D	
Decal Removal and Replacement		4-38
Destruction of Materiel to Prevent Enemy Use		1-3
Drying Water Soaked Areas in Panels		4-25
	E	
ECU Panel Assembly		4-15
Electrical System Schematic Diagram		4-39
Equipment Container		4-24
Equipment Data		1-9
Explanation of Columns in Section II		B-2, C-3, E-2
Explanation of Columns in Section III		B-3
Explanation of Listing		D-3
External Connections		2-15
	F	
Field Manuals		A-3
Floor Panel/Base Frame		4-23, 6-2

INDEX (continued)

Subject		Paragraph, Figure, Table Number
	F (cont)	
Forms		A-2
Front End Panel		4-19
Front End Panel Mounted Controls and Indicators		2-3
	G	
General		2-5, 2-17 3-1, 3-3 4-4, 5-1 6-1, C-2, D-2
	I	
Incandescent Light Assembly		410
	L	
Leveling Shelter		2-13
List of Abbreviations		16
Location and Description of Major Components		18
Location of Identification and Instruction Plates		2-12
	M	
Maintenance Forms, Records, and Reports		12
	O	
Operating Instructions		2-16
Operation During Blackout Conditions		2-21
Operation in High Winds		2-20
Operation in Rain and/or Mud		2-18
Operation in Snow, Ice or Extreme Cold		2-19
Operator Troubleshooting		3-2
Organizational Maintenance Troubleshooting		4-6
	P	
Paint Refinishing		4-37
Personnel Door		4-17
Power Entry Panel Assembly		48
Preparation for Storage and Shipment		4-43
Preparation for Use		28
Preventive Maintenance Checks and Services Table		2-7
Purpose of Nonexpandable Tactical Shelter		1-7

INDEX (continued)

Subject	Paragraph, Figure, Table Number
R	
Raceway Assembly	4-16.1
Rear Endwall Panel	4-20
Deleted	
Receptacle Outlets	4-12
Repair of Damage With Extended Cracks	4-31
Repair of Depression of Small Puncture	4-28
Repair of Puncture Through Both Skins and Core	4-33
Repair of Puncture Through One Skin and Core	4-32
Repair of Puncture With Core Fracture	4-30
Repair of Puncture With Minimal) Damage to Core	4-29
Repair of Small Dent or Depression	4-27
Repair Parts	4-3
Reporting Equipment Improvement Recommendations (EIR's)	1-5
Roof Panel	4-22, 5-2
S	
Scope	1-1, 2-1, A-1 B-1, C-1, D-1 E-1
Shelter Body Seals Replacement	4-34
Shelter Handling	2-11
Shelter Inspection Checklist	2-10
Shelter Inventory Checks	2-9
Sidewall Panel	4-21
Special Instructions	2-6
Special Tools, TMDE, and Support Equipment	4-2
Storm Configuration Components Replacement	3-7
T	
Technical Manuals	A-4
Threaded Inserts Replacement	4-35
Troubleshooting	4-5
W	
Wall Switch	4-13
Wire List	4-40
Wiring	4-16

By Order of the Secretary of the Army:

Official:

JOHN A. WICKHAM, JR.
General, United States Army
Chief of Staff

R. L. DILWORTH
Brigadier General, United States Army
The Adjutant General

DISTRIBUTION:

To be distributed in accordance with DA Form 12-25A, Operator, Organizational, Direct Support and General Support Maintenance requirements for Shelter, Expandable, Rigid Construction, w/Air Lock Model SEY-2 (TM 10-5410-221 Series) and Shelter, Expandable, Shop, Aircraft Maintenance, Portable (TM 10-5410-224 Series).

These are the instructions for sending an electronic 2028

The following format must be used if submitting an electronic 2028. The subject line must be exactly the same and all fields must be included; however, only the following fields are mandatory: 1, 3, 4, 5, 6, 7, 8, 9, 10, 13, 15, 16, 17, and 27.

From: "Whoever" whoever@avma27.army.mil

To: amssbriml@natick.army.mil Subject: DA Form 2028

1. *From:* Joe Smith
2. *Unit home*
3. *Address:* 4300 Park
4. *City:* Hometown
5. *St:* MO
6. *Zip:* 77777
7. *Date Sent:* 19-OCT-93
8. *Pub no:* 55-2840-229-23
9. *Pub Title:* TM
10. *Publication Date:* 04-JUL-85
11. *Change Number:* 7
12. *Submitter Rank:* MSG
13. *Submitter FName:* Joe
14. *Submitter MName:* T
15. *Submitter LName:* Smith
16. *Submitter Phone:* 123-123-1234
17. *Problem:* 1
18. *Page:* 2
19. *Paragraph:* 3
20. *Line:* 4
21. *NSN:* 5
22. *Reference:* 6
23. *Figure:* 7
24. *Table:* 8
25. *Item:* 9
26. *Total:* 123
27. *Text:*

This is the text for the problem below line 27.

RECOMMENDED CHANGES TO PUBLICATIONS AND BLANK FORMS For use of this form, see AR 25-30; the proponent agency is ODISC4.						Use Part II (reverse) for Repair Parts and Special Tool Lists (RPSTL) and Supply Catalogs/Supply Manuals (SC/SM).	DATE 21 October 2003
TO: (Forward to proponent of publication or form) (Include ZIP Code) COMMANDER U.S. ARMY TANK-AUTOMOTIVE AND ARMAMENT COMMAND ATTN: AMSTA-LC-CECT 15 KANSAS STREET NATICK, MA 01760-5052						FROM: (Activity and location) (Include ZIP Code) <i>PFC Jane Doe</i> <i>CO A 3rd Engineer BR</i> <i>Ft. Leonardwood, MO 63108</i>	
PART I – ALL PUBLICATIONS (EXCEPT RPSTL AND SC/SM) AND BLANK FORMS							
PUBLICATION/FORM NUMBER TM 10-1670-296-23&P				DATE 30 October 2002	TITLE Ancillary Equipment for Low Velocity Air Drop Systems		
ITEM NO.	PAGE NO.	PARA-GRAPH	LINE NO. *	FIGURE NO.	TABLE NO.	RECOMMENDED CHANGES AND REASON <i>(Provide exact wording of recommended changes, if possible).</i>	
	0036 00-2				1	<i>In table 1, Sewing Machine Code Symbols, the second sewing machine code symbol should be MD ZZ not MD 22.</i> <i>Change the manual to show Sewing Machine, Industrial: Zig-Zag; 308 stitch; medium-duty; NSN 3530-01-181-1421 as a MD ZZ code symbol.</i>	
<i>*Reference to line numbers within the paragraph or subparagraph.</i>							
TYPED NAME, GRADE OR TITLE Jane Doe, PFC				TELEPHONE EXCHANGE/AUTOVON, PLUS EXTENSION 508-233-4141		SIGNATURE Jane Doe <i>Jane Doe</i>	

TO: (Forward direct to addressee listed in publication) COMMANDER U.S. ARMY TANK-AUTOMOTIVE AND ARMAMENT COMMAND ATTN: AMSTA-LC-CECT 15 KANSAS STREET NATICK, MA 01760-5052	FROM: (Activity and location) (Include ZIP Code) <i>PFC Jane Doe</i> <i>CO A 3rd Engineer BR</i> <i>Ft. Leonardwood, MO 63108</i>	DATE 21 October 2003
---	--	--------------------------------

PART II – REPAIR PARTS AND SPECIAL TOOL LISTS AND SUPPLY CATALOGS/SUPPLY MANUALS

PUBLICATION NUMBER TM 10-1670-296-23&P	DATE 30 October 2002	TITLE Ancillary Equipment for Low Velocity Air Drop Systems
--	--------------------------------	---

PAGE NO.	COLM NO.	LINE NO.	NATIONAL STOCK NUMBER	REFERENCE NO.	FIGURE NO.	ITEM NO.	TOTAL NO. OF MAJOR ITEMS SUPPORTED	RECOMMENDED ACTION
0066 00-1					4			<i>Callout 16 in figure 4 is pointed to a <u>D-Ring</u>. In the Repair Parts List key for figure 4, item 16 is called a <u>Snap Hook</u>. Please correct one or the other.</i>

SAMPLE

PART III – REMARKS

(Any general remarks or recommendations, or suggestions for improvement of publications and blank forms. Additional blank sheets may be used if more space is needed.)

TYPED NAME, GRADE OR TITLE	TELEPHONE EXCHANGE/AUTOVON, PLUS EXTENSION	SIGNATURE
----------------------------	--	-----------

TO: <i>(Forward direct to addressee listed in publication)</i> COMMANDER U.S. ARMY TANK-AUTOMOTIVE AND ARMAMENT COMMAND ATTN:AMSTA-LC-CECT 15 KANSAS STREET NATICK, MA 01760-5052	FROM: <i>(Activity and location) (Include ZIP Code)</i>	DATE
---	--	-------------

PART II – REPAIR PARTS AND SPECIAL TOOL LISTS AND SUPPLY CATALOGS/SUPPLY MANUALS

PUBLICATION NUMBER TM 10-5411-202-14	DATE 9 December 1987	TITLE Operator, Organizational, Direct Support for Shelter, Tactical, Nonexpandable
---	-------------------------	---

PAGE NO.	COLM NO.	LINE NO.	NATIONAL STOCK NUMBER	REFERENCE NO.	FIGURE NO.	ITEM NO.	TOTAL NO. OF MAJOR ITEMS SUPPORTED	RECOMMENDED ACTION

PART III – REMARKS

(Any general remarks or recommendations, or suggestions for improvement of publications and blank forms. Additional blank sheets may be used if more space is needed.)

TYPED NAME, GRADE OR TITLE	TELEPHONE EXCHANGE/AUTOVON, PLUS EXTENSION	SIGNATURE
----------------------------	--	-----------

TO: <i>(Forward direct to addressee listed in publication)</i> COMMANDER U.S. ARMY TANK-AUTOMOTIVE AND ARMAMENT COMMAND ATTN:AMSTA-LC-CECT 15 KANSAS STREET NATICK, MA 01760-5052	FROM: <i>(Activity and location) (Include ZIP Code)</i>	DATE
---	--	-------------

PART II – REPAIR PARTS AND SPECIAL TOOL LISTS AND SUPPLY CATALOGS/SUPPLY MANUALS

PUBLICATION NUMBER TM 10-5411-202-14	DATE 9 December 1987	TITLE Operator, Organizational, Direct Support for Shelter, Tactical, Nonexpandable
---	-------------------------	--

PAGE NO.	COLM NO.	LINE NO.	NATIONAL STOCK NUMBER	REFERENCE NO.	FIGURE NO.	ITEM NO.	TOTAL NO. OF MAJOR ITEMS SUPPORTED	RECOMMENDED ACTION

PART III – REMARKS

(Any general remarks or recommendations, or suggestions for improvement of publications and blank forms. Additional blank sheets may be used if more space is needed.)

TYPED NAME, GRADE OR TITLE	TELEPHONE EXCHANGE/AUTOVON, PLUS EXTENSION	SIGNATURE
----------------------------	--	-----------

The Metric System and Equivalents

Linear Measure

1 centimeter = 10 millimeters = .39 inch
 1 decimeter = 10 centimeters = 3.94 inches
 1 meter = 10 decimeters = 39.37 inches
 1 dekameter = 10 meters = 32.8 feet
 1 hectometer = 10 dekameters = 328.08 feet
 1 kilometer = 10 hectometers = 3,280.8 feet

Weights

1 centigram = 10 milligrams = .15 grain
 1 decigram = 10 centigrams = 1.54 grains
 1 gram = 10 decigrams = .035 ounce
 1 dekagram = 10 grams = .35 ounce
 1 hectogram = 10 dekagrams = 3.52 ounces
 1 kilogram = 10 hectograms = 2.2 pounds
 1 quintal = 100 kilograms = 220.46 pounds
 1 metric ton = 10 quintals = 1.1 short tons

Liquid Measure

1 centiliter = 10 milliliters = .34 fl. ounce
 1 deciliter = 10 centiliters = 3.38 fl. ounces
 1 liter = 10 deciliters = 33.81 fl. ounces
 1 dekaliter = 10 liters = 2.64 gallons
 1 hectoliter = 10 dekaliters = 26.42 gallons
 1 kiloliter = 10 hectoliters = 264.18 gallons

Square Measure

1 sq. centimeter = 100 sq. millimeters = .155 sq. inch
 1 sq. decimeter = 100 sq. centimeters = 15.5 sq. inches
 1 sq. meter (centare) = 100 sq. decimeters = 10.76 sq. feet
 1 sq. dekameter (are) = 100 sq. meters = 1,076.4 sq. feet
 1 sq. hectometer (hectare) = 100 sq. dekameters = 2.47 acres
 1 sq. kilometer = 100 sq. hectometers = .386 sq. mile

Cubic Measure

1 cu. centimeter = 1000 cu. millimeters = .06 cu. inch
 1 cu. decimeter = 1000 cu. centimeters = 61.02 cu. inches
 1 cu. meter = 1000 cu. decimeters = 35.31 feet

Approximate Conversion Factors

<i>To change</i>	<i>To</i>	<i>Multiply by</i>	<i>To change</i>	<i>To</i>	<i>Multiply by</i>
inches	centimeters	2.540	ounce-inches	newton-meters	.007062
feet	meters	.305	centimeters	inches	.394
yards	meters	.914	meters	feet	3.280
miles	kilometers	1.609	meters	yards	1.094
square inches	square centimeters	6.451	kilometers	miles	.621
square feet	square meters	.093	square centimeters	square inches	.155
square yards	square meters	.836	square meters	square feet	10.764
square miles	square kilometers	2.590	square meters	square yards	1.196
acres	square hectometers	.405	square kilometers	square miles	.386
cubic feet	cubic meters	.028	square hectometers	acres	2.471
cubic yards	cubic meters	.765	cubic meters	cubic feet	35.315
fluid ounces	milliliters	29.573	cubic meters	cubic yards	1.308
pints	liters	.473	milliliters	fluid ounces	.034
quarts	liters	.946	liters	pints	2.113
gallons	liters	3.785	liters	quarts	1.057
ounces	grams	28.349	liters	gallons	.264
pounds	kilograms	.454	grams	ounces	.035
short tons	metric tons	.907	kilograms	pounds	2.205
pound-feet	newton-meters	1.356	metric tons	short tons	1.102
pound-inches	newton-meters	.11296			

Temperature (Exact)

 _F Fahrenheit temperature $\times \frac{5}{9}$ (after subtracting 32) = Celsius temperature _C

